

GLASSFRONT MERCHANDISER (III SERIES)

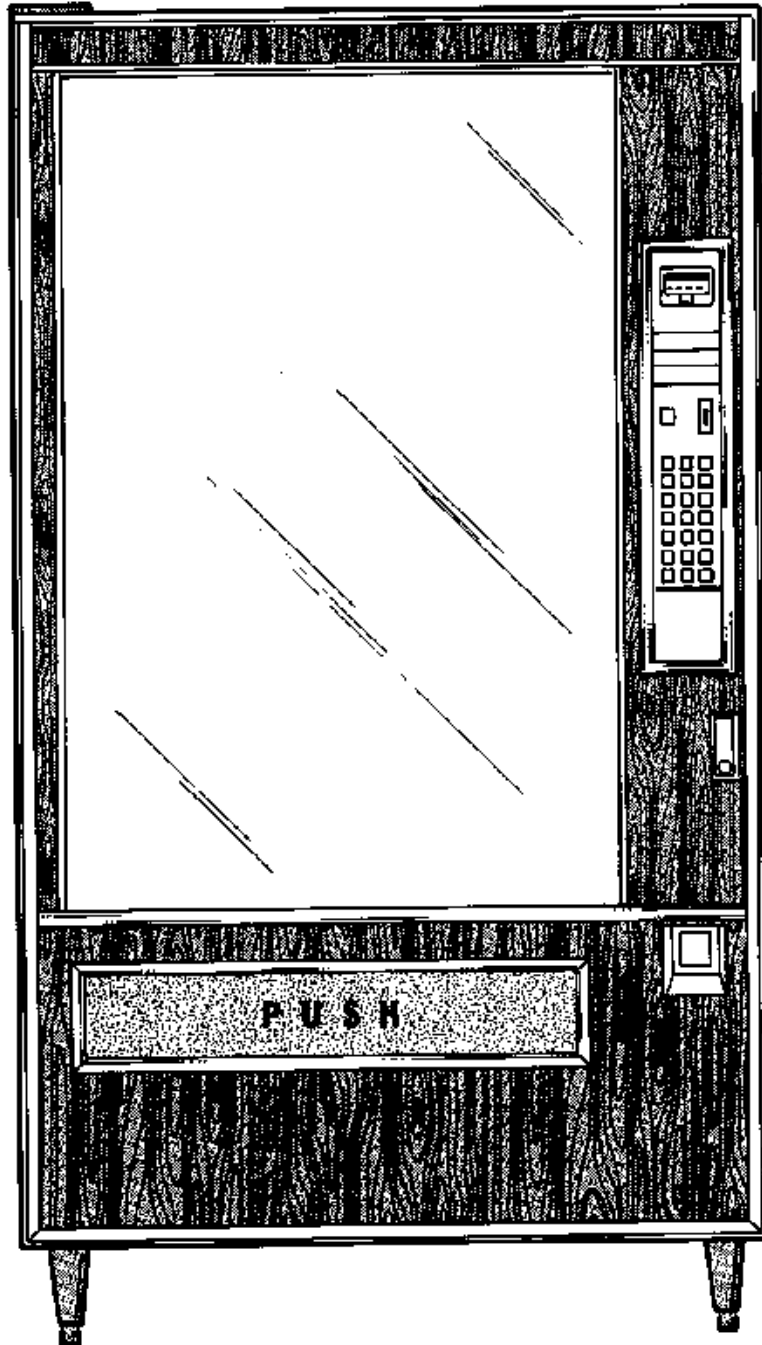

PARTS MANUAL

JUNE, 1990

P/N 4202014

MODEL	SIZE	VOLTAGE USE
3013	3-WIDE	110 VOLTS
3014	4-WIDE	110 VOLTS
3015	5-WIDE	110 VOLTS
3023	3-WIDE	220-240 VOLTS
3024	4-WIDE	220-240 VOLTS
3025	5-WIDE	220-240 VOLTS
3026	4-WIDE	A/C 110 VOLTS
3021	5-WIDE	A/C 110 VOLTS
3022	4-WIDE	A/C 220-240 VOLTS
3020	5-WIDE	A/C 220-240 VOLTS

TABLE OF CONTENTS

GENERAL INFORMATION	1-2
STYLINGS	3-6
STYLING PACKAGE - PARTS	7-8
COMMON DOOR ASSEMBLY	9-10
COMPLETE DELIVERY ASSEMBLY	11-12
COMPLETE DOOR LATCH ASSEMBLY	13-14
COMPLETE LIGHT ASSEMBLY	13-14
COMMON CABINET ASSEMBLY	15-16, 16X
GUM & MINT TRAY ASSEMBLY	17X, 17-18
METAL TRAY ASSEMBLY	19-20
PLASTIC TRAY ASSEMBLY	21-22
MICROWAVE PRODUCT ASSEMBLY	23-24
COMPLETE CONTROL PANEL ASSEMBLY	25-26
COMPLETE COIN INSERT ASSEMBLY	27-28
COMPLETE TRANSFORMER BOX ASSEMBLY	27-28
COMMON AIR CONDITIONED CABINET ASSEMBLY	29-30
COMPLETE AIR CONDITIONING UNIT	31-32
FINAL ASSEMBLY	33-34
NOTES	35

GENERAL INFORMATION

Welcome to Selectivend, Inc., we offer you three convenient ways to order replacement parts. If you have any questions when placing your order, please call and we'll be happy to assist you. Please provide the following information when placing your order:

Quantity Required
Part Number
Description
Vendor Model
Serial Number

Shipping and Billing Address
Preferred Method of Shipment
Customer Account Number

TO ORDER BY MAIL:

You may place your requirements for replacement parts by providing the necessary information as requested above, and mailing your order to:

Selectivend, Inc.
P.O. Box 488
Waukee, Iowa 50263

If you have any questions, please call (515) 274-3641, ask for Selectivend, Inc. and we will be happy to assist you.

Order forms are available upon request from Selectivend, Inc. or you may use your own purchase order form.

TO ORDER BY FAX MACHINE:

(515) 987-4447

You may Fax your order for replacement parts by providing the necessary information as requested above, to Selectivend, Inc. by using our Fax (515) 987-4447.

If you have any questions, so indicate and we will respond via Fax, with your answer.

TO ORDER BY PHONE:

(515) 274-3641

You may call in your order for replacement parts. Ask for Selectivend, Inc. Please provide the necessary information, as requested above, to allow us to provide you with prompt and courteous service.

If you have any questions, so indicate and we will be happy to assist you.

GENERAL INFORMATION

TERMS:

- MINIMUM ORDER \$25.00. You may wish to inquire on prices of parts at the time of your order. If your order is less than the minimum, please check our catalog for other parts you may require to bring your order up to the \$25.00 minimum order.
- OPEN ACCOUNT with approved credit
- MASTER CARD — VISA — C.O.D.

If you have any questions, please call and we will be happy to assist you.

RETURNS:

RESTOCKING CHARGE 20%. A restocking charge of 20% will apply to merchandise accepted by Selectivend for return, except items processed as a warranty.

All items returned must be accompanied by a "material return tag" clearly stating the reason for the return. Returns are to be shipped freight prepaid to Selectivend, Inc., Highway 6 and Route 22, Waukee, Iowa 50263. (Tags are available upon request from Selectivend.)

If you have any questions regarding returns, please call Selectivend, Inc. (515) 274-3641, we will be happy to assist you.

LIMITATION OF LIABILITY:

Selectivend, Inc. shall not be liable for any injury, loss or damage, whether direct, incidental or consequential arising out of the use of or the inability to use any part, parts or products sold by Selectivend, Inc. The remedies of the buyer set forth herein are exclusive, and the liability of Selectivend, Inc. with respect to any contract or sale or anything done in connection therewith, whether in contract, in tort, under any warranty, or otherwise, shall not, except as expressly provided herein, exceed the price of the part, parts or products on which such liability is based. Any statements or representations about the parts or product, other than those contained herein, do not constitute warranties and shall not be relied on by the buyer and shall have no force or effect unless contained in a written agreement signed by officers of Selectivend, Inc.

STYLINGS

PRESIDENTIAL WALNUT "A"

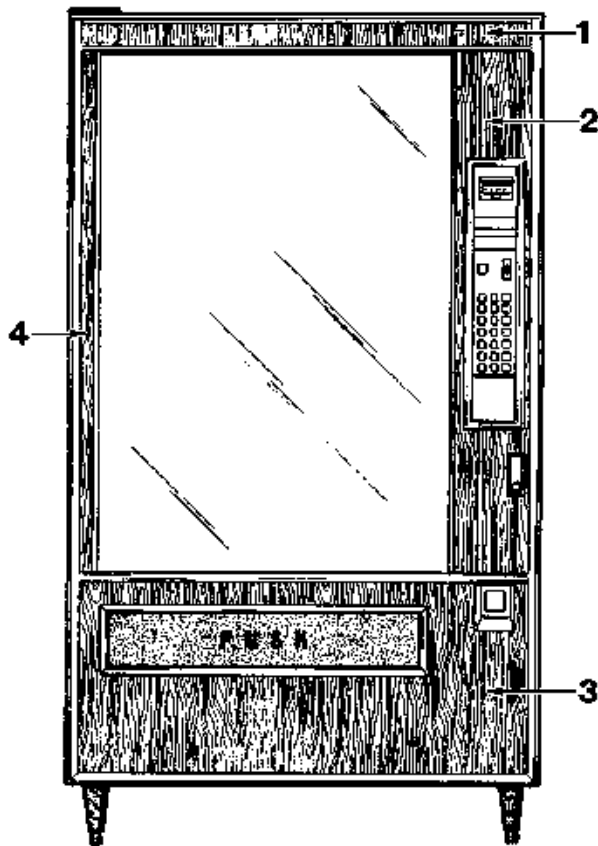

	ITEM	PART NUMBER	PART DESCRIPTION
3	--	1210704-003	PRESIDENTIAL WALNUT "A"
W I D E	1	4201119-003	PRESIDENTIAL WALNUT
	2	4201120-001	PRESIDENTIAL WALNUT
	3	4201123-001	PRESIDENTIAL WALNUT
	4	4201118-001	PRESIDENTIAL WALNUT
4	--	1210704-004	PRESIDENTIAL WALNUT "A"
W I D E	1	4201119-002	PRESIDENTIAL WALNUT
	2	4201120-001	PRESIDENTIAL WALNUT
	3	4201122-001	PRESIDENTIAL WALNUT
	4	4201118-001	PRESIDENTIAL WALNUT
5	--	1210704-005	PRESIDENTIAL WALNUT "A"
W I D E	1	4201119-001	PRESIDENTIAL WALNUT
	2	4201120-001	PRESIDENTIAL WALNUT
	3	4201121-001	PRESIDENTIAL WALNUT
	4	4201118-001	PRESIDENTIAL WALNUT

* ALL STYLINGS NOT AVAILABLE

PRESIDENTIAL WALNUT "B"

	ITEM	PART NUMBER	PART DESCRIPTION
3	--	1210704-013	PRESIDENTIAL WALNUT "B"
W I D E	1	4201119-015	BLACK MOROCCO
	2	4201120-005	BLACK MOROCCO
	3	4201123-001	PRESIDENTIAL WALNUT
	4	4201118-001	PRESIDENTIAL WALNUT
4	--	1210704-014	PRESIDENTIAL WALNUT "B"
W I D E	1	4201119-014	BLACK MOROCCO
	2	4201120-005	BLACK MOROCCO
	3	4201122-001	PRESIDENTIAL WALNUT
	4	4201118-001	PRESIDENTIAL WALNUT
5	--	1210704-015	PRESIDENTIAL WALNUT "B"
W I D E	1	4201119-013	BLACK MOROCCO
	2	4201120-005	BLACK MOROCCO
	3	4201121-001	PRESIDENTIAL WALNUT
	4	4201118-001	PRESIDENTIAL WALNUT

* ALL STYLINGS NOT AVAILABLE

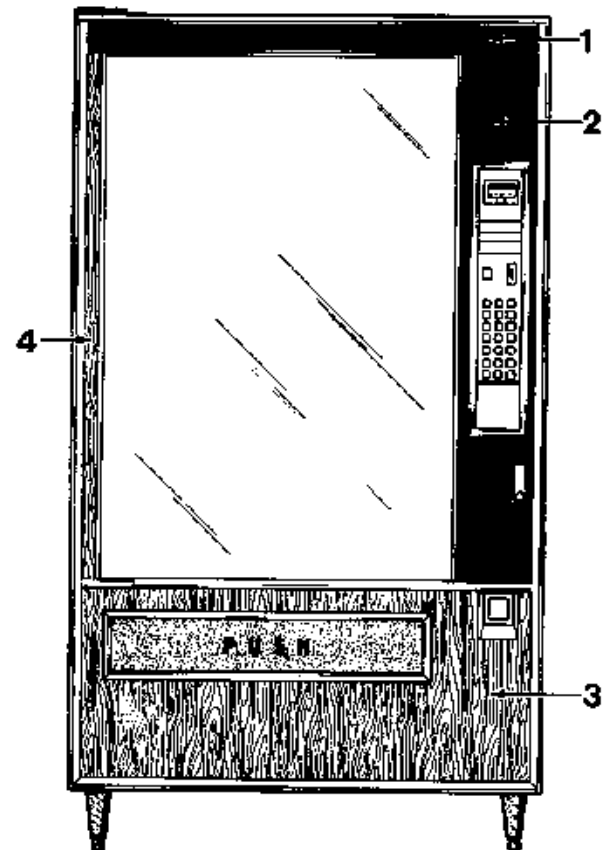

IMPERIAL CROWN

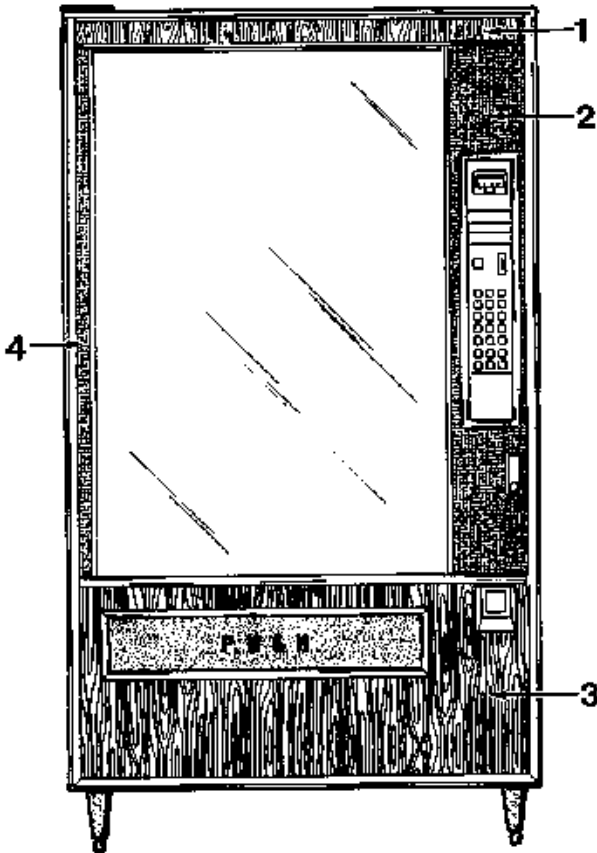

	ITEM	PART NUMBER	PART DESCRIPTION	
	3	--	1210704-010	IMPERIAL CROWN
W I D E	1	4201119-003	PRESIDENTIAL WALNUT	
	2	4201120-003	PORT-AU-PRINCE	
	3	4201123-001	PRESIDENTIAL WALNUT	
	4	4201118-003	PORT-AU-PRINCE	
	4	--	1210704-011	IMPERIAL CROWN
W I D E	1	4201119-002	PRESIDENTIAL WALNUT	
	2	4201120-003	PORT-AU-PRINCE	
	3	4201122-001	PRESIDENTIAL WALNUT	
	4	4201118-003	PORT-AU-PRINCE	
	5	--	1210704-012	IMPERIAL CROWN
W I D E	1	4201119-001	PRESIDENTIAL WALNUT	
	2	4201120-003	PORT-AU-PRINCE	
	3	4201121-001	PRESIDENTIAL WALNUT	
	4	4201118-003	PORT-AU-PRINCE	

* ALL STYLINGS NOT AVAILABLE

ROWE AWARD

	ITEM	PART NUMBER	PART DESCRIPTION	
	3	--	1210704-001	ROWE AWARD
W I D E	1	4201119-006	ROSEWOOD	
	2	4201120-004	SILVER SAFARI	
	3	4201123-002	ROSEWOOD	
	4	4201118-004	SILVER SAFARI	
	4	--	1210704-002	ROWE AWARD
W I D E	1	4201119-005	ROSEWOOD	
	2	4201120-004	SILVER SAFARI	
	3	4201122-002	ROSEWOOD	
	4	4201118-004	SILVER SAFARI	
	5	--	1210704-006	ROWE AWARD
W I D E	1	4201119-004	ROSEWOOD	
	2	4201120-004	SILVER SAFARI	
	3	4201121-002	ROSEWOOD	
	4	4201118-004	SILVER SAFARI	

* ALL STYLINGS NOT AVAILABLE

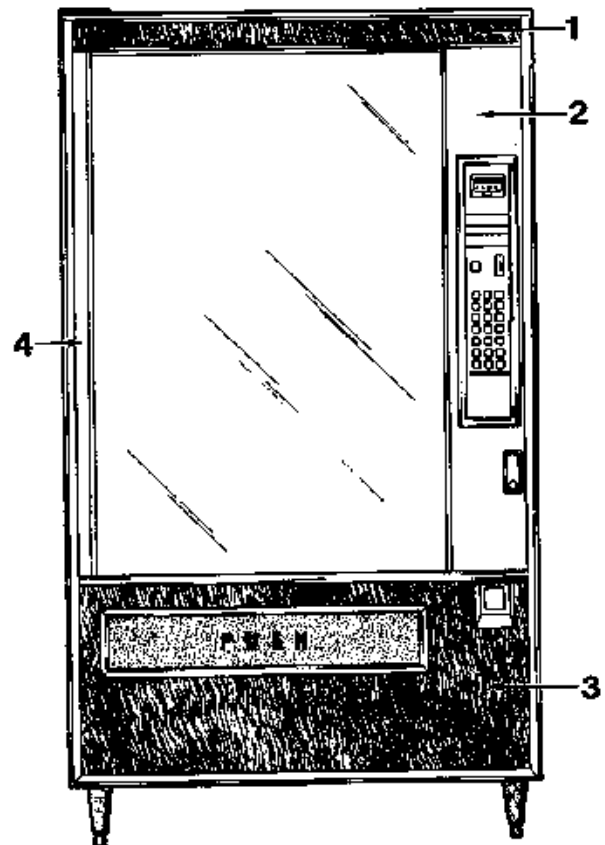

HONEYTONE TEAK

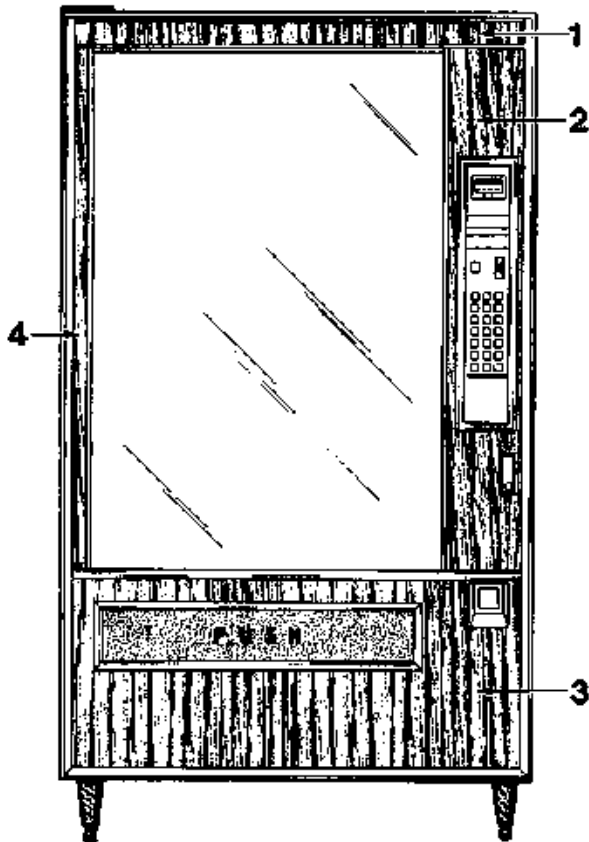

	ITEM	PART NUMBER	PART DESCRIPTION
3	--	1210704-016	HONEYTONE TEAK
W I D E	1	4201119-035	HONEYTONE TEAK
	2	4201120-009	HONEYTONE TEAK
	3	4201123-009	HONEYTONE TEAK
	4	4201118-009	HONEYTONE TEAK
4	--	1210704-018	HONEYTONE TEAK
W I D E	1	4201119-036	HONEYTONE TEAK
	2	4201120-009	HONEYTONE TEAK
	3	4201122-009	HONEYTONE TEAK
	4	4201118-009	HONEYTONE TEAK
5	--	1210704-019	HONEYTONE TEAK
W I D E	1	4201119-037	HONEYTONE TEAK
	2	4201120-009	HONEYTONE TEAK
	3	4201121-009	HONEYTONE TEAK
	4	4201118-009	HONEYTONE TEAK

* ALL STYLINGS NOT AVAILABLE

RENAISSANCE BLUE

	ITEM	PART NUMBER	PART DESCRIPTION
3	--	1210704-022	RENAISSANCE BLUE
W I D E	1	4201119-032	RENAISSANCE BLUE
	2	4201120-008	RENAISSANCE BLUE
	3	4201123-008	RENAISSANCE BLUE
	4	4201118-008	RENAISSANCE BLUE
4	--	1210704-023	RENAISSANCE BLUE
W I D E	1	4201119-033	RENAISSANCE BLUE
	2	4201120-008	RENAISSANCE BLUE
	3	4201122-008	RENAISSANCE BLUE
	4	4201118-008	RENAISSANCE BLUE
5	--	1210704-024	RENAISSANCE BLUE
W I D E	1	4201119-034	RENAISSANCE BLUE
	2	4201120-008	RENAISSANCE BLUE
	3	4201121-008	RENAISSANCE BLUE
	4	4201118-008	RENAISSANCE BLUE

* ALL STYLINGS NOT AVAILABLE

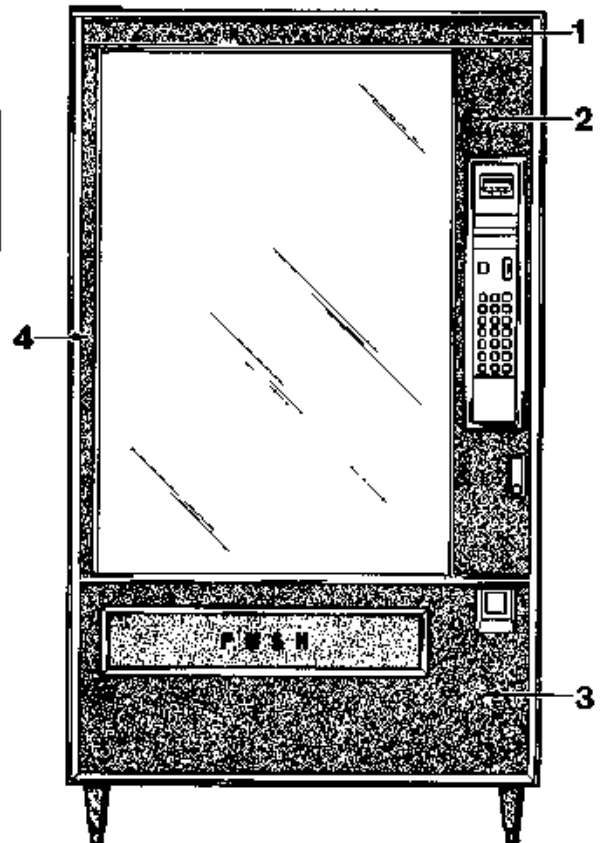

HIGH TECH

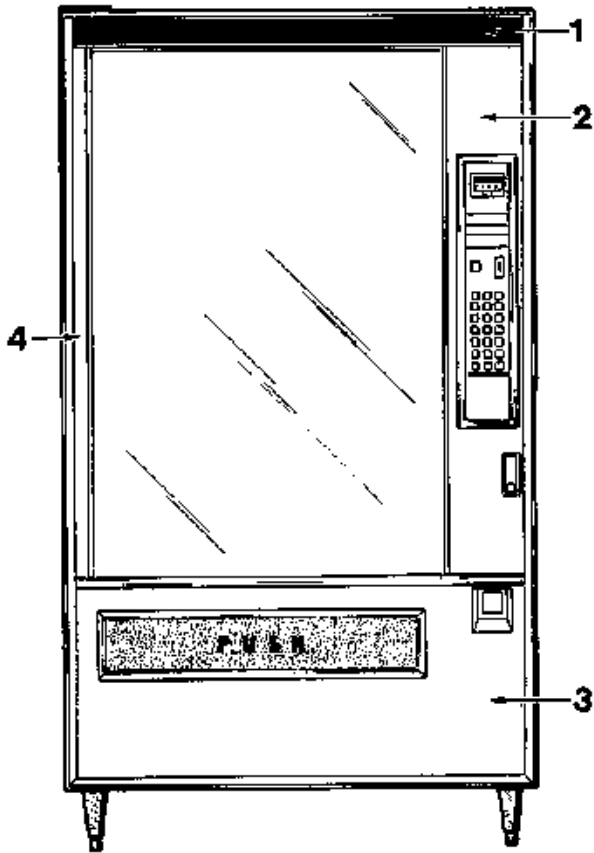

	ITEM	PART NUMBER	PART DESCRIPTION
3	--	1210704-007	HIGH TECH
W I D E	1	4201119-015	BLACK MOROCCO
	2	4201120-007	BRUSHED STAINLESS
	3	4201123-007	BRUSHED STAINLESS
	4	4201118-007	BRUSHED STAINLESS
4	--	1210704-008	HIGH TECH
W I D E	1	4201119-014	BLACK MOROCCO
	2	4201120-007	BRUSHED STAINLESS
	3	4201122-007	BRUSHED STAINLESS
	4	4201118-007	BRUSHED STAINLESS
5	--	1210704-009	HIGH TECH
W I D E	1	4201119-013	BLACK MOROCCO
	2	4201120-007	BRUSHED STAINLESS
	3	4201121-007	BRUSHED STAINLESS
	4	4201118-007	BRUSHED STAINLESS

* ALL STYLINGS NOT AVAILABLE

STYLING PACKAGE - PARTS

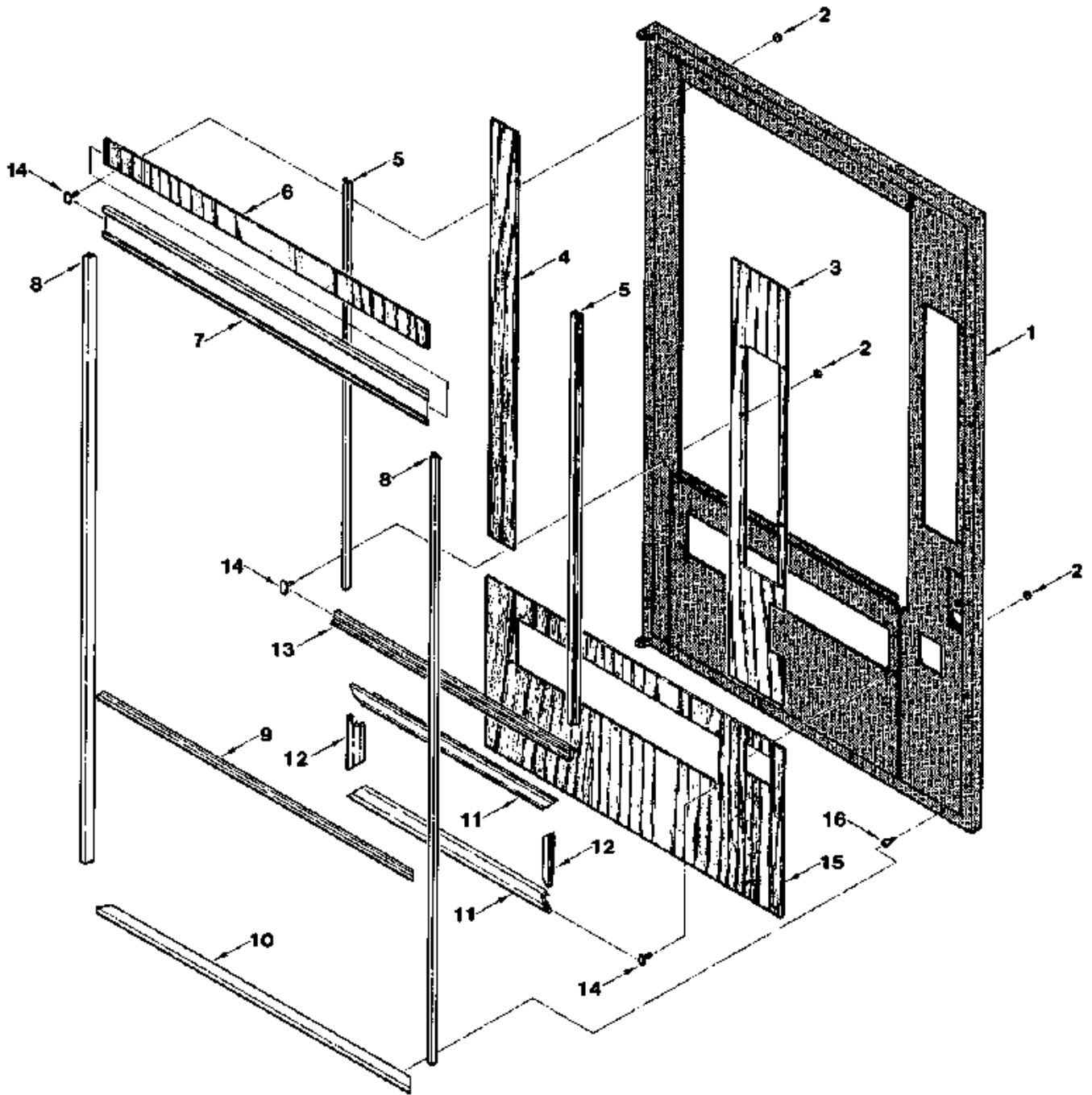

STYLING PACKAGE - PARTS

ITEM	PART NUMBER	3 WIDE	4 WIDE	4 WIDE A/C	5 WIDE	5 WIDE A/C	DESCRIPTION
1	1210702-003	1	—	—	—	—	DOOR WELD ASSY.
	1210702-004	—	1	—	—	—	DOOR WELD ASSY.
	1210702-005	--	--	—	1	--	DOOR WELD ASSY.
	1210702-007	--	—	1	--	--	DOOR WELD ASSY.
	1210702-006	--	—	—	—	1	DOOR WELD ASSY.
2	4050513	10	10	10	10	10	#8-32 TWIN WHIZ LOCKNUT
3	4201120-XXX	1	1	1	1	1	OUTER PANEL - RIGHT
4	4201118-XXX	1	1	1	1	1	OUTER PANEL - LEFT
5	4022405-005	2	2	2	2	2	TRIM DISPLAY/BRUSHED SILVER
	4022405-007	2	2	2	2	2	TRIM DISPLAY/ETCHED SILVER
6	4201119-XXX	1	1	1	1	1	UPPER PANEL - TRIM INSERT
7	8362965-028	1	--	--	--	--	TRIM/BRUSHED SILVER
	8362965-027	--	1	1	--	--	TRIM/BRUSHED SILVER
	8362965-026	--	--	--	1	1	TRIM/BRUSHED SILVER
	8362965-034	1	--	--	--	--	TRIM/ETCHED SILVER
	8362965-035	--	1	1	--	--	TRIM/ETCHED SILVER
	8362965-036	--	--	--	1	1	TRIM/ETCHED SILVER
8	4201117-002	2	2	2	2	2	TRIM/BRUSHED SILVER
	4201117-009	2	2	2	2	2	TRIM/BRUSHED BLACK
	4201117-026	2	2	2	2	2	TRIM/ETCHED SILVER
	4201117-030	2	2	2	2	2	TRIM/ETCHED BLACK
9	8383670-008	—	—	—	—	—	TRIM/BRUSHED SILVER
	8383670-009	--	1	1	--	--	TRIM/BRUSHED SILVER
	8383670-010	--	--	--	1	1	TRIM/BRUSHED SILVER
	8383670-027	1	—	—	--	--	TRIM/ETCHED SILVER
	8383670-028	1	1	1	--	--	TRIM/ETCHED SILVER
	8383670-029	1	--	--	1	1	TRIM/ETCHED SILVER
10	4201117-018	1	--	--	--	--	TRIM/BRUSHED SILVER
	4201117-019	--	1	1	--	--	TRIM/BRUSHED SILVER
	4201117-020	--	--	--	1	1	TRIM/BRUSHED SILVER
	4201117-015	1	--	--	--	--	TRIM/BRUSHED BLACK
	4201117-016	--	1	1	--	--	TRIM/BRUSHED BLACK
	4201117-017	--	--	--	1	1	TRIM/BRUSHED BLACK
	4201117-023	1	--	--	--	--	TRIM/ETCHED SILVER
	4201117-024	--	1	1	--	--	TRIM/ETCHED SILVER
	4201117-025	--	--	--	1	1	TRIM/ETCHED SILVER
	4201117-027	1	--	--	--	--	TRIM/ETCHED BLACK
	4201117-028	--	1	1	--	--	TRIM/ETCHED BLACK
	4201117-029	--	--	--	1	1	TRIM/ETCHED BLACK
11	4022357-016	2	--	--	--	--	TRIM-EXTR./BRUSHED SILVER
	4022357-017	--	2	2	--	--	TRIM-EXTR./BRUSHED SILVER
	4022357-018	--	--	--	2	2	TRIM-EXTR./BRUSHED SILVER
	4022357-019	2	--	--	--	--	TRIM-EXTR./ETCHED SILVER
	4022357-020	--	2	2	--	--	TRIM-EXTR./ETCHED SILVER
	4022357-021	--	--	--	2	2	TRIM-EXTR./ETCHED SILVER
12	4022357-015	2	2	2	2	2	TRIM-EXTR./BRUSHED SILVER
	4022357-022	2	2	2	2	2	TRIM-EXTR./ETCHED SILVER
13	4022406-005	1	--	--	--	--	TRIM-DISPLAY/BRUSHED SILVER
	4022406-004	--	1	1	--	--	TRIM-DISPLAY/BRUSHED SILVER
	4022406-006	--	--	--	1	1	TRIM-DISPLAY/BRUSHED SILVER
	4022406-011	1	--	--	--	--	TRIM-DISPLAY/ETCHED SILVER
	4022406-012	--	1	1	--	--	TRIM-DISPLAY/ETCHED SILVER
	4022406-013	--	--	--	1	1	TRIM-DISPLAY/ETCHED SILVER
14	4050724	16	16	16	16	16	#8-32x3/8 TEE BOLT
15	4201123-XXX	1	--	--	--	--	LOWER PANEL
	4201122-XXX	--	1	1	--	--	LOWER PANEL
	4201121-XXX	--	--	--	1	1	LOWER PANEL
16	4201116	17	18	18	18	18	#10x3/8 TRIM HD. SMS

A/C = AIR CONDITIONED I = SEE STYLING SECTIONS

COMMON DOOR ASSEMBLY

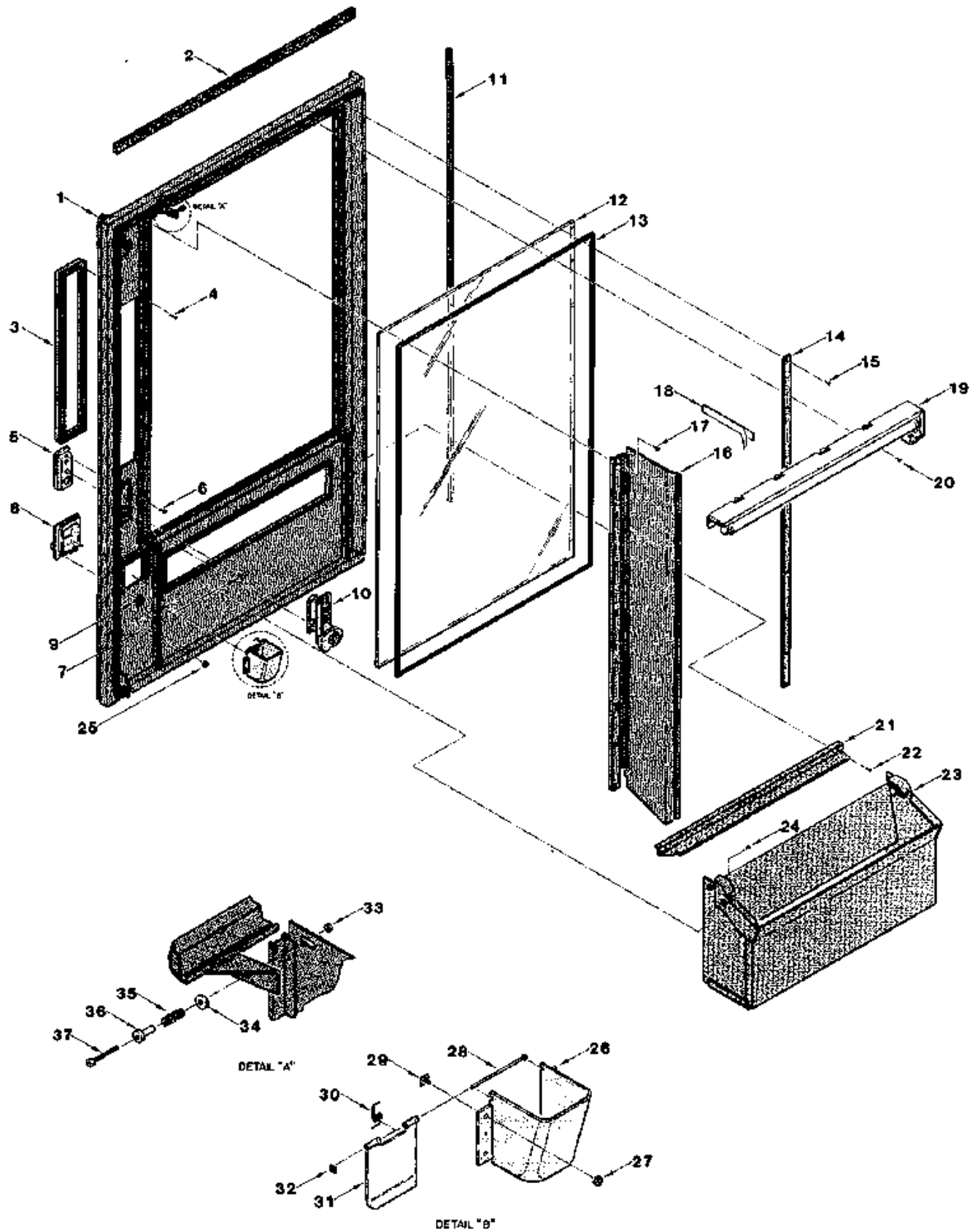

COMMON DOOR ASSEMBLY

ITEM	PART NUMBER	3 WIDE	4 WIDE	4 WIDE A/C	5 WIDE	5 WIDE A/C	DESCRIPTION
--	1210727-003	1	--	--	--	--	COMMON DOOR ASSY.
--	1210727-004	--	1	--	--	--	COMMON DOOR ASSY.
--	1210942-004	--	--	1	--	--	COMMON DOOR ASSY.
--	1210727-005	--	--	--	1	--	COMMON DOOR ASSY.
--	1210942-005	--	--	--	--	1	COMMON DOOR ASSY.
1	1210702-003	1	--	--	--	--	DOOR WELD ASSY.
.	1210702-004	--	1	--	--	--	DOOR WELD ASSY.
.	1210702-007	--	--	1	--	--	DOOR WELD ASSY.
.	1210702-005	--	--	--	1	--	DOOR WELD ASSY.
.	1210702-006	--	--	--	--	1	DOOR WELD ASSY.
2	4201527	10FT	11FT	--	12FT	--	DOOR GASKET 3/4"
.	4201419-004	--	--	1	--	--	DOOR GASKET - A/C
.	4201419-005	--	--	--	--	1	DOOR GASKET - A/C
3	4060667	1	1	1	1	1	BEZEL - SELECTOR PANEL
4	4050212	8	8	8	8	8	#8-32x1/4 PHIL PH TYP-T
5	8369526	1	1	1	1	1	TRIM - LATCH
6	8800829	1	1	1	1	1	#10-24x3/8 PHIL TH W/ETW
7	8800831	1	1	1	1	1	1/4-20x1/2 PH TH TYP-T
8	8379619	1	1	1	1	1	COIN CUP TRIM
9	8322904	2	2	2	2	2	#10 SELF THREAD NUT
10	1127161-3	1	1	1	1	1	DOOR LATCH ASSY. (PG. 13)
11	4201528	5.5FT	5.5FT	--	5.5FT	--	DOOR GASKET 1/2"
"	4201419-004	--	--	1	--	--	DOOR GASKET - A/C
"	4201419-005	--	--	--	--	1	DOOR GASKET - A/C
12	4060673-003	1	--	--	--	--	DISPLAY GLASS
"	4060673-004	--	1	--	--	--	DISPLAY GLASS
"	4060673-000	--	--	--	1	1	DISPLAY GLASS
13	4201108-003	1	--	--	--	--	GASKET - GLASS
.	4201108-004	--	1	--	--	--	GASKET - GLASS
.	4201108-005	--	--	--	1	1	GASKET - GLASS
14	4003118	1	1	1	1	1	RETAINER - GLASS (LEFT)
15	8800638	8	8	8	8	8	#10-16x3/8 PHIL PH TYP-B
16	1210763-002	1	--	--	--	--	DISPLAY SIDE SHIELD
17	8800638	8	8	8	8	8	#10-16x3/8 PHIL PH TYP-B
18	4200900	6 IN	6 IN	6 IN	6 IN	6 IN	TEFLON TAPE
19	1210718-003	1	--	--	--	--	LIGHT ASSY. (PG. 13)
.	1210718-004	--	1	--	--	--	LIGHT ASSY. (PG. 13)
.	1210718-005	--	--	--	1	1	LIGHT ASSY. (PG. 13)
20	8800638	2	3	3	4	4	#10-16x3/8 PHIL PH TYP-B
21	4201192-003	1	--	--	--	--	PRODUCT DEFLECTOR
.	4201192-004	--	1	--	--	--	PRODUCT DEFLECTOR
.	4201192-005	--	--	--	1	1	PRODUCT DEFLECTOR
22	4050212	3	4	4	5	5	#8-32x1/4 PHIL PH TYP-T
23	1210734-003	1	--	--	--	--	DELIVERY ASSY. (PG. 11)
.	1210734-004	--	1	--	--	--	DELIVERY ASSY. (PG. 11)
.	1210734-007	--	--	1	--	--	DELIVERY ASSY. (PG. 11)
.	1210734-005	--	--	--	1	--	DELIVERY ASSY. (PG. 11)
.	1210734-006	--	--	--	--	1	DELIVERY ASSY. (PG. 11)
24	4050240	4	4	4	4	4	#8-32x3/8 PHIL PH
25	4050513	4	4	4	4	4	#8-32 TWIN WHIZ LOCKNUT
26	8349894-000	1	1	1	1	1	COIN CUP
27	8800952	4	4	4	4	4	#10-32 HEX NUT W/ETW
28	8346087-1	4	4	4	4	4	PIN
29	8328761	4	4	4	4	4	#10-32x13/32 TEE BOLT
30	8350338	1	1	1	1	1	DOOR SPRING
31	8349892-2	1	1	1	1	1	COIN CUP DOOR
32	8337564	1	1	1	1	1	125 DIA STD PUSH NUT
33	8800952	1	1	1	1	1	#10-32 HEXNUT W/ETW
34	8801018	1	1	1	1	1	5/16 FLAT WASHER
35	4201178-002	1	1	1	1	1	LOCK ROD SPRING
36	4030002	1	1	1	1	1	RESET INNER BUSHING
37	4050790	1	1	1	1	1	#10-32x 1/4 PHIL PH SCW

A/C = AIR CONDITIONED

COMPLETE DELIVERY ASSEMBLY

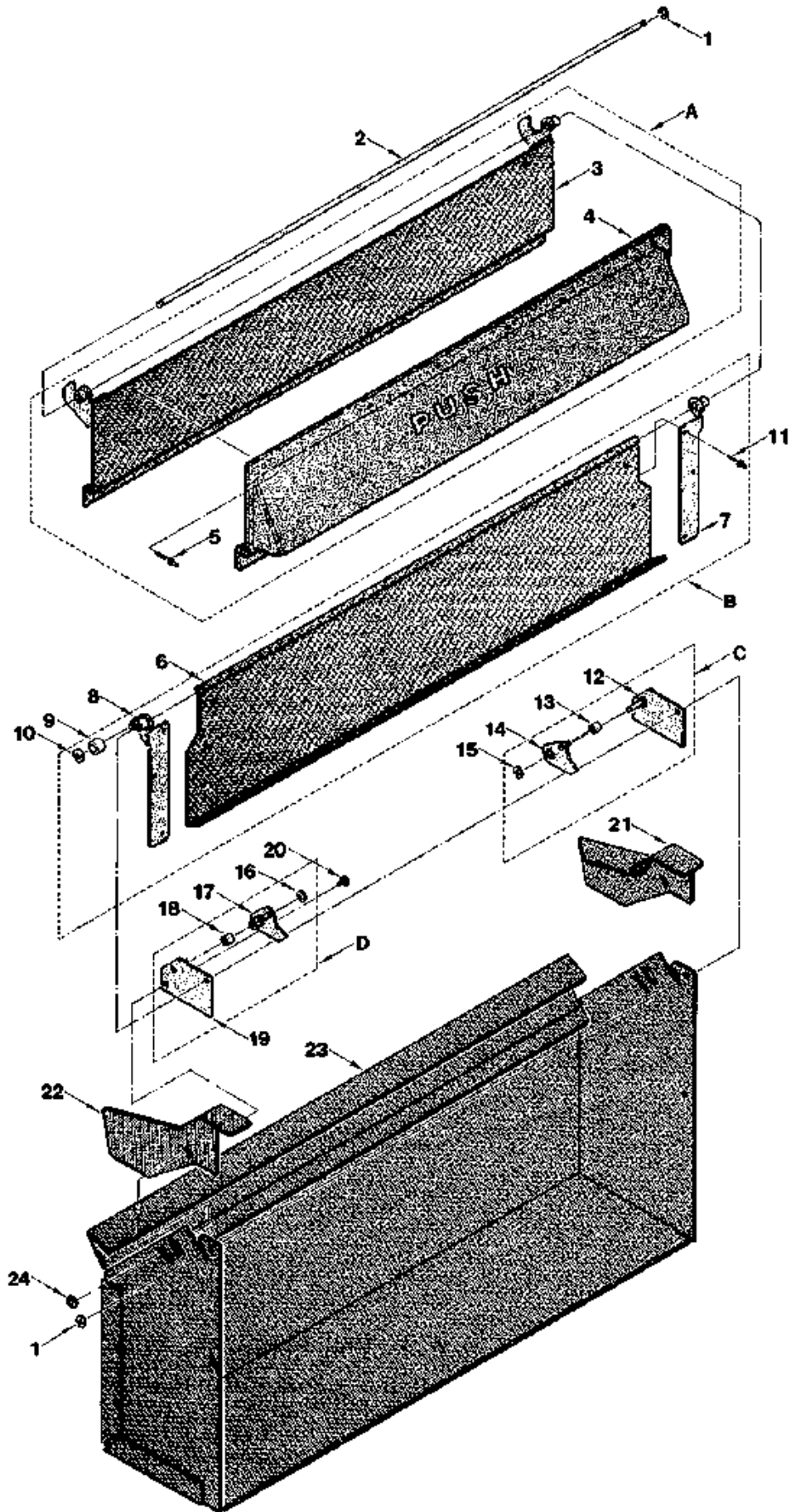

COMPLETE DELIVERY ASSEMBLY

ITEM	PART NUMBER	3 WIDE	4 WIDE	4 WIDE A/C	5 WIDE	5 WIDE A/C	DESCRIPTION
--	1210734-003	1	--	--	--	--	COMPLETE DELIVERY ASSY.
--	1210734-004	--	1	--	--	--	COMPLETE DELIVERY ASSY.
--	1210734-007	--	--	1	--	--	COMPLETE DELIVERY ASSY.
--	1210734-005	--	--	--	1	--	COMPLETE DELIVERY ASSY.
--	1210734-006	--	--	--	--	1	COMPLETE DELIVERY ASSY.
1-19	1210735-003	1	--	--	--	--	VEND DOOR ASSY./PARTS 1-19
"	1210735-004	--	1	--	--	--	VEND DOOR ASSY./PARTS 1-19
"	1210735-005	--	--	--	1	1	VEND DOOR ASSY./PARTS 1-19
1	8801080	2	2	2	2	2	E-RING
2	4060490-003	1	--	--	--	--	SHAFT - DELIVERY
"	4060490-004	--	1	1	--	--	SHAFT - DELIVERY
"	4060490-005	--	--	--	1	1	SHAFT - DELIVERY
A	1210849-003	1	--	--	--	--	DELIVERY DOOR RIVET ASSY.
"	1210849-004	--	1	1	--	--	DELIVERY DOOR RIVET ASSY.
"	1102806-001	1	--	--	1	1	DELIVERY DOOR RIVET ASSY.
3	1210815	1	--	--	--	--	DELIVERY BACK PLATE WLD
"	1210816	--	1	1	--	--	DELIVERY BACK PLATE WLD
"	1102928-002	--	--	--	1	1	DELIVERY BACK PLATE WLD
4	4025742	1	--	--	--	--	DELIVERY DOOR
"	4200045-000	--	1	1	--	--	DELIVERY DOOR
"	8380325	--	--	--	1	1	DELIVERY DOOR
5	4050667	6	10	10	10	10	RIVET
B	1210813-003	1	--	--	--	--	ANTI-CHEAT RIVET ASSY.
"	1210813-004	--	1	1	--	--	ANTI-CHEAT RIVET ASSY.
"	1102899	--	--	--	1	1	ANTI-CHEAT RIVET ASSY.
6-8, 11	1211063-003	1	--	--	--	--	ANTI-CHEAT PANEL ASSY.
"	1211063-004	--	1	1	--	--	ANTI-CHEAT PANEL ASSY.
"	1211063-005	--	--	--	1	1	ANTI-CHEAT PANEL ASSY.
6	4003147-006	1	--	--	--	--	ANTI-CHEAT PANEL/BLACK
"	4003147-007	--	1	1	--	--	ANTI-CHEAT PANEL/BLACK
"	4003147-000	--	--	--	1	1	ANTI-CHEAT PANEL/BLACK
7	1102925-000	1	1	1	1	1	HINGE WELD ASSY. RT.
8	1102925-001	1	1	1	1	1	HINGE WELD ASSY. LFT.
9	4030410	2	2	2	2	2	BUSHING/ANTI-CHEATING
10	8801080	2	2	2	2	2	E-RING
11	4050667	6	6	6	6	6	RIVET
C	1102929-001	1	1	1	1	1	BACK UP PLATE ASSY. RT.
12	1102892-001	1	1	1	1	1	CAM WELD ASSY. RT.
13	4060499	1	1	1	1	1	NEEDLE BEARING (ROLLER)
14	1102923-001	1	1	1	1	1	STAKE ASSY. RT.
15	8801080	1	1	1	1	1	E-RING
D	1102929-000	1	1	1	1	1	BACK UP PLATE ASSY. LFT.
16	8801080	1	1	1	1	1	E-RING
17	1102923-000	1	1	1	1	1	STAKE ASSY. LFT.
18	4060499	1	1	1	1	1	NEEDLE BEARING (ROLLER)
19	1102892-000	1	1	1	1	1	CAM WELD ASSY. LFT.
20	7188598-000	2	2	2	2	2	#10-32x3/8 CARRG. BOLT
21	4200140-001	1	1	1	1	1	PRODUCT DEFLECTOR RT.
22	4200140-000	1	1	1	1	1	PRODUCT DEFLECTOR LFT.
23	1210733-003	1	--	--	--	--	DELIVERY WELD/BLACK
"	1210733-004	--	1	--	--	--	DELIVERY WELD/BLACK
"	1210733-016	--	--	1	--	--	DELIVERY WELD/BLACK
"	1210733-005	--	--	--	1	--	DELIVERY WELD/BLACK
"	1210733-014	--	--	--	--	1	DELIVERY WELD/BLACK
24	4050546	2	2	2	2	2	#10-32 TWIN WHIZ NUT

A/C = AIR CONDITIONED

COMPLETE DOOR LATCH ASSEMBLY & COMPLETE LIGHT ASSEMBLY

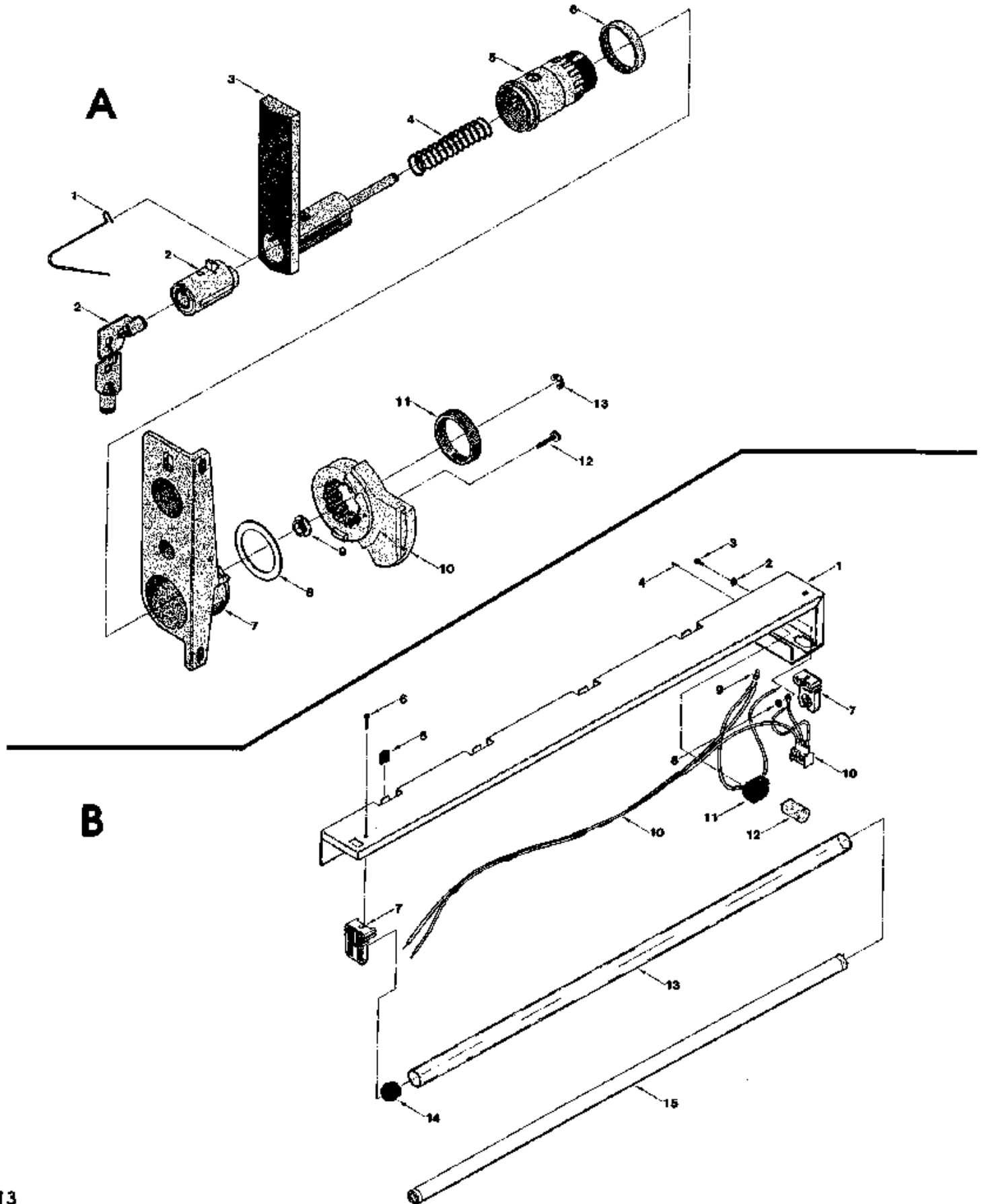

COMPLETE DOOR LATCH ASSEMBLY & COMPLETE LIGHT ASSEMBLY

A ITEM	PART NUMBER	3 WIDE	4 WIDE	4 WIDE A/C	5 WIDE	5 WIDE A/C	DESCRIPTION
1	▲8382998	1	1	1	1	1	CLIP - LATCH RETAINER
2	▲4060330	1	1	1	1	1	LOCK CYLINDER/2 KEYS
-	1127161-3	1	1	1	1	1	DOOR LATCH ASSY.
3	8387105	1	1	1	1	1	HANDLE - LATCH
4	8365664	1	1	1	1	1	SPRING
5	1127162	1	1	1	1	1	OPERATING TUBE ASSY.
6	8369076	1	1	1	1	1	BEARING - CAM
7	8365668	1	1	1	1	1	HOUSING - LATCH
8	8366501-1	1	1	1	1	1	WASHER 1 3/16 PLASTIC
9	8375353	1	1	1	1	1	BUSHING NYLON
10	8384285	1	1	1	1	1	CAM LOCK
11	8365777	1	1	1	1	1	1 1/8x16 RETAINING NUT
12	8800824	1	1	1	1	1	#8-32x5/8 PHIL TH TYP-T
13	8801080	1	1	1	1	1	SPRING

A/C = AIR CONDITIONED

▲ = OPTIONAL

B ITEM	PART NUMBER	3 WIDE	4 WIDE	4 WIDE A/C	5 WIDE	5 WIDE A/C	DESCRIPTION
-	1210718-003	-	-	-	-	-	COMPLETE LIGHT ASSY.
-	1210718-004	-	1	1	-	-	COMPLETE LIGHT ASSY.
-	1210718-005	-	-	-	1	1	COMPLETE LIGHT ASSY.
1	1210802-003	1	-	-	-	-	LIGHT BRKT. WELD ASSY./WHT
"	1210802-004	-	1	1	-	-	LIGHT BRKT. WELD ASSY./WHT
"	1210802-005	-	-	-	1	1	LIGHT BRKT. WELD ASSY./WHT
2	4050585	1	1	1	1	1	#8 EXT. TOOTH LOCKWASHER
3	4050240	1	1	1	1	1	#8-32x3/8 PHIL PH
4	4050018	2	2	2	2	2	#4-40x3/8 PHIL PH MS
5	8620828	2	3	3	4	4	4 PIN COVER
6	4050113	2	2	2	2	2	#6-32x1/2 PHIL PH MS-PLT
7	4033548	2	2	2	2	2	FLUORESCENT LAMP HOLDER
8	4050513	1	1	1	1	1	#8-32 TWIN WHIZ LOCKNUT
9	4033505	1	1	1	1	1	CLOSED END SPLICE CAP
10	4201232	1	-	-	-	-	LIGHT HARNESS
"	4201233	-	1	1	-	-	LIGHT HARNESS
"	4201282	-	-	-	1	1	LIGHT HARNESS
11	4033617	1	1	1	1	1	STARTER SOCKET
12	4033567	1	-	-	-	-	STARTER FS-2
"	4033661	-	1	1	1	1	STARTER FS-25
13	▲4025764	1	-	-	-	-	SAFETY TUBE
"	▲4025764-004	-	1	1	-	-	SAFETY TUBE
"	▲4025764-005	-	-	-	1	1	SAFETY TUBE
14	▲4033713-002	2	2	2	2	2	SAFETY TUBE END CAPE
15	4033549	1	-	-	-	-	LAMP
"	4034135	-	1	1	-	-	LAMP
"	4033513	-	-	-	1	1	LAMP

A/C = AIR CONDITIONED

▲ = OPTIONAL

COMMON CABINET ASSEMBLY

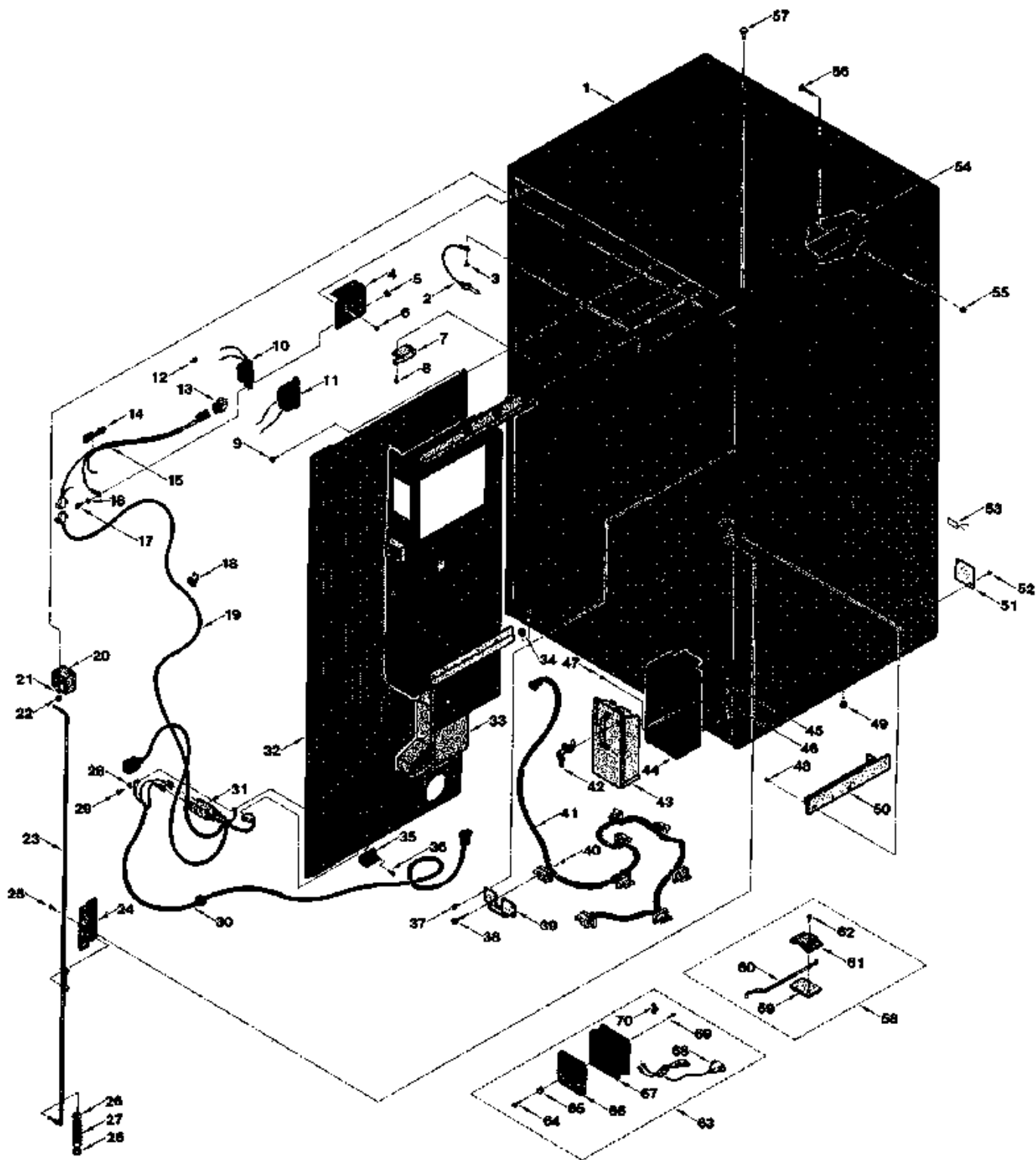

COMMON CABINET ASSEMBLY

ITEM	PART NUMBER	3 WIDE	4 WIDE	4 WIDE A/C	5 WIDE	6 WIDE A/C	DESCRIPTION
--	1210728-003	--	--	--	--	--	COMMON CABINET ASSY.
--	1210728-004	--	--	--	--	--	COMMON CABINET ASSY.
--	1210728-005	--	--	--	1	--	COMMON CABINET ASSY.
--	1210968-004	--	--	1	--	--	COMMON CABINET ASSY.
--	1210968-005	--	--	--	--	1	COMMON CABINET ASSY.
--	*1210871-003	--	--	--	--	--	COMMON CABINET ASSY.
--	*1210871-004	--	1	--	--	--	COMMON CABINET ASSY.
--	*1210871-005	--	--	--	1	--	COMMON CABINET ASSY.
--	*1210943-004	--	--	1	--	--	COMMON CABINET ASSY.
--	*1210943-005	--	--	--	--	1	COMMON CABINET ASSY.
1	1211044-003	1	--	--	--	--	CABINET WELD ASSY.
"	1211044-004	--	1	--	--	--	CABINET WELD ASSY.
"	1211044-005	--	--	--	1	--	CABINET WELD ASSY.
"	1210930-004	--	--	1	--	--	CABINET WELD ASSY.
"	1210930-005	--	--	--	--	1	CABINET WELD ASSY.
2	1211019	1	1	1	1	1	PIN & CABLE ASSY.
3	4050180	1	1	1	1	1	#8-18x1/2 PHIL PH TEK
4	4201287-002	1	1	1	1	1	BALLAST MTG BRKT/BLACK
5	4050513	2	2	2	2	2	#8-32 TWIN WHIZ LOCKNUT
6	7331309-000	2	2	2	2	2	#8-18x1/2 PHIL TH SMS
7	1211072	1	1	1	1	1	SIDE SHIELD BRKT ASSY.
8	8800636	2	2	2	2	2	#8-18x1/2 PHIL PH TYP-B
9	8800636	4	4	4	4	4	#8-18x1/2 PHIL PH TYP-B
10	4033609	1	--	--	--	--	BALLAST
"	4033669	--	1	1	1	1	BALLAST
11	*4033074	1	--	--	--	--	BALLAST - (220-240 VOLT)
"	*4034088	--	1	1	1	1	BALLAST - (220-240 VOLT)
12	4033505	2	2	2	2	2	CLOSED END SPLICE
13	4034426-002	1	1	1	1	1	PLUG MATE N LOCK
14	4201243	1	1	1	1	1	STRAIN RELIEF
15	4201283	1	1	1	1	1	BALLAST HARNESS
16	4050585	2	2	2	2	2	#8 EXT. TOOTH LOCKWASHER
17	4050240	2	2	2	2	2	#8-32x7/8 PHIL PH SMS
18	7200341-000	8	8	8	8	8	TUBE CLIP
19	4200701	1	1	1	1	1	CABINET POWER HARNESS
20	4201131-002	2	2	2	2	2	LOCK ROD GUIDE
21	4050084	2	2	2	2	2	1/4 SPUT LOCKWASHER
22	4050547	2	2	2	2	2	1/4-20 TWIN WHIZ NUT
23	1210716-002	1	1	1	1	1	LOCK BAR WELD
24	4201179-002	1	1	1	1	1	LOCK STRIKE
25	4050379	2	2	2	2	2	1/4-20x1/2 PHIL PH TARTITE
26	8801018	2	2	2	2	2	5/16 FLAT WASHER
27	4201178-003	1	1	1	1	1	LOCK ROD SPRING
28	4050585	1	1	1	1	1	#8 EXT. TOOTH LOCKWASHER
29	8800636	1	1	1	1	1	#8-18x1/2 PHIL PH TYP-B
30	4033631-001	1	1	1	1	1	POWER CABLE W/GROMMET
31	4033527	2	2	2	2	2	CIG CLIP
32	4201167-002	1	1	--	1	--	PARTITION PANEL/BLACK
"	4201677-002	--	--	--	--	--	PARTITION PANEL/BLACK
33	1210852	1	1	--	1	--	CONTROL PANEL ASSY. (PG. 25)
"	1210969	--	--	1	--	1	CONTROL PANEL ASSY. (PG. 25)
"	*1210874	1	1	--	1	--	CONTROL PANEL ASSY. (PG. 25)
"	*1210944	--	--	1	--	1	CONTROL PANEL ASSY. (PG. 25)
34	7250135-000	4, 5	4, 5	4, 5	4, 5	4, 5	HOLE PLUG - 1/3/8"
35	4201177-002	2	2	2	2	2	PARTITION BRACE
36	8800636	8	8	8	8	8	#8-18x1/2 PHIL PH TYP-B
37	4050792	14	14	14	14	14	#10-16x1/2 PHIL PH TYP-B
38	4060674	14	14	14	14	14	#8-32x7/8 SHOULDER SCREW
39	4200280-001	7	7	7	7	7	PLUG BRKT.
40	4050548-000	14	14	14	14	14	SCREW COVER/WHITE
41	4200697	--	--	1	--	--	CABINET MOTOR HARNESS
42	4060366	--	--	1	--	--	LOCK - COIN BOX W/KEYS

A/C = AIR CONDITIONED * = INTERNATIONAL USE ONLY ▲ = OPTIONAL

GUM & MINT TRAY ASSEMBLY

ITEM	PART NUMBER	3 WIDE	4 WIDE	4 WIDE A/C	5 WIDE	5 WIDE A/C	DESCRIPTION
-	1210774-003	-	-	-	-	-	GUM & MINT TRAY ASSY.
-	1210774-004	-	1	1	-	-	GUM & MINT TRAY ASSY.
-	1210774-005	-	-	-	1	1	GUM & MINT TRAY ASSY.
1	1102444	1	-	-	-	-	COVER WELD ASSY.
1	1200024-000	1	1	1	1	1	COVER WELD ASSY.
1	1102420	-	-	-	1	1	COVER WELD ASSY.
2	8383131	1	1	1	1	1	SPRING - COVER
3	8383241	2	2	2	2	2	PIN - LID HINGE
4	4003370	2	2	2	4	4	SPACER - SMALL PRODUCT
5	8383129-001	1	2	2	3	3	PARTITION - REMOVABLE
-	1211038-003	1	-	-	-	-	TRAY - SCREW ASSY.
-	1211038-004	-	1	1	-	-	TRAY - SCREW ASSY.
-	1211038-005	-	-	-	1	1	TRAY - SCREW ASSY.
6	1210558	1	-	-	-	-	TRAY RIVET ASSY.
-	1210556	-	1	1	-	-	TRAY RIVET ASSY.
-	1210527	-	-	-	1	1	TRAY RIVET ASSY.
7	4060172	4	4	4	4	4	ROLLER - NYLON
8	8801193	4	4	4	4	4	#8-32x3/8 PHIL RH MS-SS
9	4050420	2	2	2	2	2	#8-18x1/4 PHIL HWH TYP-B
10	4003781	1	-	-	-	-	SOLD OUT RETAINER
-	4200050-000	-	1	1	-	-	SOLD OUT RETAINER
-	4003748	-	-	-	1	1	SOLD OUT RETAINER
11	1131020	3	4	4	5	5	PUSHER ASSY.
12	8383066	3	4	4	5	5	PUSHER
13	8801134	3	4	4	5	5	1/8 x 1 PIN
14	8383081	3	4	4	5	5	BEARING - PUSHER SPRING
15	8383337	3	4	4	5	5	SPRING - COILED BAND
16	1131095	3	4	4	5	5	GATE ASSY.
17	8383091	3	4	4	5	5	SECTION - GATE HINGE
18	8383224	3	4	4	5	5	PIN - GATE HINGE
19	8383067	3	4	4	5	5	SPRING - GATE
20	8383092	3	4	4	5	5	GATE - PRODUCT
21	4201874-000	3	4	4	5	5	#8-32 WING NUT - STAMPED
22	4020865	1	-	-	-	-	LABEL - 3 SEL GUM & MINT
-	4200062-000	-	1	1	-	-	LABEL - 4 SEL GUM & MINT
-	4020860	-	-	-	1	1	LABEL - 5 SEL GUM & MINT
23	8520154	1	1	1	1	1	PRICE BLANK - \$1.45
24	8520155	1	1	1	1	1	PRICE BLANK - \$1.50 - \$1.75
25	4022404	2	2	2	2	2	EXTRUSION - TRACK
26	4050420	8	8	8	8	8	#8-18x1/4 PHIL HWH TYP-B
-	1210755-003	1	-	-	-	-	DRAWER BASE SCREW ASSY.
-	1210755-004	-	1	1	-	-	DRAWER BASE SCREW ASSY.
-	1210755-005	-	-	-	1	1	DRAWER BASE SCREW ASSY.
27	1102428	-	-	-	1	1	DRAWER BASE WELD ASSY.
28	1200002-000	-	-	-	-	-	DRAWER BASE WELD ASSY.
-	1200002-001	-	1	1	-	-	DRAWER BASE WELD ASSY.
-	1200002-002	-	-	-	1	1	DRAWER BASE WELD ASSY.
29	4050423	4	4	4	4	4	#8-18x3/8 PHIL PH TYP-AB
30	8801193	4	4	4	4	4	#8-32x3/8 PHIL RH MS-SS
31	4060172	4	4	4	4	4	ROLLER - NYLON
32	4050494	4	4	4	4	4	#8-32 NUT, UNI-TORQUE
33	4050495	3	4	4	4	4	#10-32 NUT, UNI-TORQUE
34	83861530	1	-	-	-	1	INTERLOCK SWITCH
-	1211039-003	-	-	-	-	-	FRONT PANEL SCREW ASSY.
-	1211039-004	-	1	1	-	-	FRONT PANEL SCREW ASSY.
-	1211039-005	-	-	-	1	1	FRONT PANEL SCREW ASSY.
35	1102435	3	4	4	-	-	MOTOR STAKE ASSY.
36	4034342	3	4	4	-	-	MOTOR
37	7332634-000	3	4	4	-	-	DRIVE PIN
38	4025679-002	3	4	4	-	-	VEND CAM - DRILLED
39	4034088	-	-	-	5	5	MOTOR
40	4025747	-	-	-	5	5	VEND CAM

A/C = AIR CONDITIONED † = NOT INCLUDED IN TRAY ASSEMBLY

COMMON CABINET ASSEMBLY

ITEM	PART NUMBER	3 WIDE	4 WIDE	4 WIDE A/C	5 WIDE	5 WIDE A/C	DESCRIPTION
43	1119032-4	1	1	1	1	1	COIN BOX WLD.
44	1210715-002	1	1	1	1	1	COIN BOX BRKT.
45	4050070	2	2	2	2	2	1/4-20x5/8 HH CAP SCREW
46	4050084	2	2	2	2	2	1/4 SPLIT LOCK WASHER
47	4050792	2	2	2	2	2	#10-16x1/2 PHIL PH TYP-B
48	7331309-000	2	2	2	2	2	#6-18x1/2 PHIL PH TYP-B
49	7250135-002	0,1	0,1	0,1	0,1	0,1	HOLE PLUG - 1 3/8
50	1210850-002	1	1	1	1	1	PANEL SLIDE WELD/PLATED
51	4201333-001	2	2	2	2	2	COVER PLATE
52	8800636	4	4	4	4	4	#8-18x1/2 PHIL PH TYP-B
53	4201375	1	1	1	1	1	TAG - GROUNDING
54	1210762-002	1	1	1	1	1	HANGER CHANEL
55	4201511	1	1	1	1	1	1/4-20x1/2 CAP SCREW
56	4050496	1	1	1	1	1	1/4-20 NUT, UNITORQUE
57	4050393	2	2	2	2	2	1/4-20x3/4 CARRIAGE BOLT
58	▲1210807	1	1	1	1	1	DOOR STOP INSTALLATION
59	▲4201409-002	1	1	1	1	1	DOOR STOP PLATE
60	▲4201407	1	1	1	1	1	DOOR STOP
61	▲4201408-002	1	1	1	1	1	DOOR STOP BRKT.
62	▲4050423	4	4	4	4	4	#8-18x3/8 PHIL PH TYP-AB
63	▲1210793	1	1	1	1	1	EXHAUST FAN ASSY.
64	▲4050180	4	4	4	4	4	#8-18x1/2 PHIL PH TEK
65	▲7332465-000	4	4	4	4	4	ANGLE - ATTACHING
66	▲4003232	1	1	1	1	1	SCREEN - AIR VENT
67	▲4034344-000	1	1	1	1	1	FAN - EVAPORATOR
68	▲4050180	4	4	4	4	4	#8-18x1/2 PHIL PH TEK
69	▲4201322	1	1	1	1	1	FAN HARNESS
70	▲4060130	3	3	3	3	3	PRESS CLIP

A/C = AIR CONDITIONED ▲ = OPTIONAL

GUM & MINT TRAY ASSEMBLY

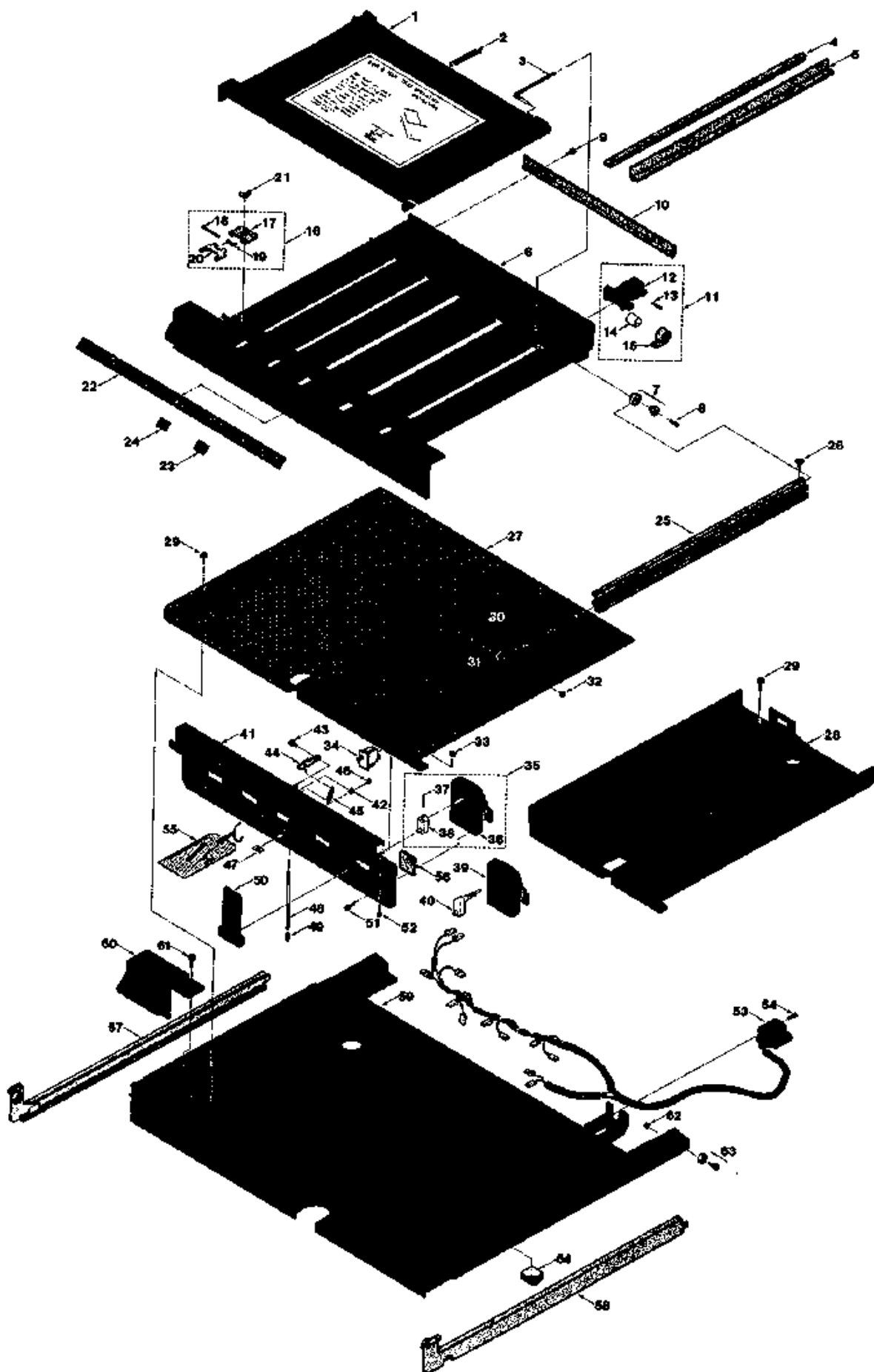

GUM & MINT TRAY ASSEMBLY

ITEM	PART NUMBER	3 WIDE	4 WIDE	4 WIDE A/C	5 WIDE	5 WIDE A/C	DESCRIPTION
41	1103032-000	1	1	1	1	1	FRONT PANEL WELD ASSY.
	1200020-000	1	1	1	1	1	FRONT PANEL WELD ASSY.
	1103031-000	1	1	1	1	1	FRONT PANEL WELD ASSY.
42	4050494	1	1	1	1	1	#8-32 NUT, UNI-TORQUE
43	8380513	1	1	1	1	1	#8-32x3/8 SHOULDER SCREW
44	8383069	1	1	1	1	1	ARM LATCH
45	4021020	1	1	1	1	1	SPRING
46	4050420	1	1	1	1	1	#8-18x1/4 PHIL HWH TYP-B
47	4050561	1	1	1	1	1	156 DIA. STUD. PUSHNUT
48	4003757	1	1	1	1	1	BAR - UNLATCHING
49	4050548-001	1	1	1	1	1	SCREW COVER - BLACK
50	4025678-001	3	4	4	5	5	PUSHER - BLACK
51	8800636	6	8	8	10	10	#8-18x1/2 PHIL PH TYP-B
52	4050423	3	4	4	4	4	#8-18x3/8 PHIL TYP-AB
	4050319	1	1	1	1	1	#10-32x3/8 PHIL FILLSTR HD
53	4034391	1	1	1	1	1	GUM & MINT HARNESS
	4200077	1	1	1	1	1	GUM & MINT HARNESS
	4034372	1	1	1	1	1	GUM & MINT HARNESS
54	8800636	2	2	2	2	2	#8-18x1/2 PHIL PH TYP-B
55	4201411	1	1	1	1	1	TRAY OPENING INSTR. TAG
56	4200285	1	1	1	1	1	SWITCH ACTUATOR PAD
57	1200321-000	1	1	1	1	1	SIDE RAIL RIVET ASSY.
58	1200321-001	1	1	1	1	1	SIDE RAIL RIVET ASSY.
59	1210758-003	1	1	1	1	1	GUM & MINT TRAY WELD
	1210758-004	1	1	1	1	1	GUM & MINT TRAY WELD
	1210758-005	1	1	1	1	1	GUM & MINT TRAY WELD
60	1210776-003	1	1	1	1	1	FILLER WELD ASSY.
	1210776-004	1	1	1	1	1	FILLER WELD ASSY.
	1210776-007	1	1	1	1	1	FILLER WELD ASSY.
61	4050423	2	2	2	2	2	#8-18x3/8 PHIL PH TYP-AB
62	4050496	2	2	2	2	2	1/4-20 NUT, UNI-TORQUE
63	4060670-001	2	2	2	2	2	ROLLER - NYLON
64	4200330-003	1	1	1	1	1	CUP

A/C = AIR CONDITIONED

STEEL TRAY ASSEMBLY

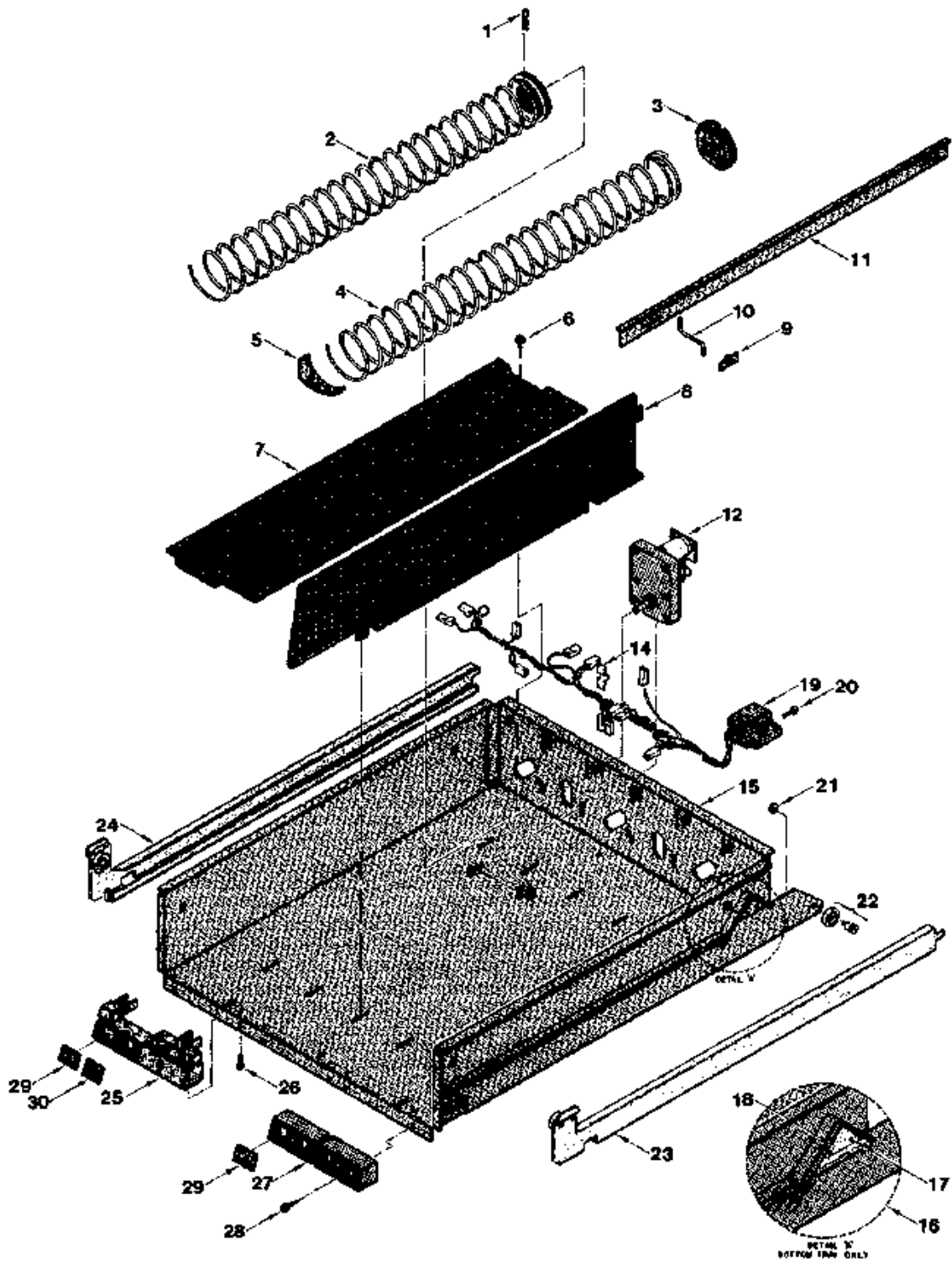

STEEL TRAY ASSEMBLY

ITEM	PART NUMBER	3 WIDE	4 WIDE	4 WIDE A/C	5 WIDE	5 WIDE A/C	DESCRIPTION
NUMBER PER TRAY							
--	1210922-001	1	--	--	--	--	TRAY ASSY. (10 CT.)
--	1210922-002	1	--	--	--	--	TRAY ASSY. (12 CT.)
--	1210922-003	1	--	--	--	--	TRAY ASSY. (12/15 CT.)
--	1210922-004	1	--	--	--	--	TRAY ASSY. (18 CT.)
--	1210922-005	1	--	--	--	--	TRAY ASSY. (15/18/24 CT.)
--	1210922-006	--	1	1	--	--	TRAY ASSY. (10 CT.)
--	1210922-007	--	1	1	--	--	TRAY ASSY. (12 CT.)
--	1210922-008	--	1	1	--	--	TRAY ASSY. (12/15 CT.)
--	1210922-009	--	1	1	--	--	TRAY ASSY. (18 CT.)
--	1210922-010	--	1	1	--	--	TRAY ASSY. (15/18/24 CT.)
1	4050773-001	3.6	4.8	4.8	--	--	HITCH PIN
2	1210561-000	6	8	8	--	--	AUGER ASSY. 15 SEL. CANDY
"	1210561-001	6	8	8	--	--	AUGER ASSY. 18 SEL. CANDY
"	1210561-002	6	8	8	--	--	AUGER ASSY. 24 SEL. CANDY
"	1210561-003	6	8	8	--	--	AUGER ASSY. 30 SEL. CANDY
"	1210561-004	6	8	8	--	--	AUGER ASSY. 12 SEL. CANDY
"	1210561-005	6	8	8	--	--	AUGER ASSY. 9 SEL. CANDY
"	1210561-006	6	8	8	--	--	AUGER ASSY. 6 SEL. CANDY
"	1210561-007	3	4	4	--	--	AUGER ASSY. 10 SEL. SNACK
"	1210561-008	3	4	4	--	--	AUGER ASSY. 12 SEL. SNACK
"	1210561-009	3	4	4	--	--	AUGER ASSY. 15 SEL. SNACK
"	1210561-010	3	4	4	--	--	AUGER ASSY. 7 SEL. SNACK
"	1210561-011	3	4	4	--	--	AUGER ASSY. 8 SEL. SNACK
3	4025745	3.6	4.8	4.8	--	--	COUPLING - AUGER
4	4200272-000	6	8	8	--	--	AUGER 15 SEL. CANDY
"	4200272-001	6	8	8	--	--	AUGER 18 SEL. CANDY
"	4200272-002	6	8	8	--	--	AUGER 24 SEL. CANDY
"	4200272-003	6	8	8	--	--	AUGER 30 SEL. CANDY
"	4200272-004	6	8	8	--	--	AUGER 12 SEL. CANDY
"	4200272-005	6	8	8	--	--	AUGER 9 SEL. CANDY
"	4200272-006	6	8	8	--	--	AUGER 6 SEL. CANDY
"	4200272-007	3	4	4	--	--	AUGER 10 SEL. SNACK
"	4200272-008	3	4	4	--	--	AUGER 12 SEL. SNACK
"	4200272-009	3	4	4	--	--	AUGER 15 SEL. SNACK
"	4200272-010	3	4	4	--	--	AUGER 7 SEL. SNACK
"	4200272-011	3	4	4	--	--	AUGER 8 SEL. SNACK
5	4025748	3.6	4.8	4.8	--	--	PRODUCT EJECTOR
6	4050420	3	4	4	--	--	#8-18x1/4 PHIL. HWH. TYP-B
7	4025749-001	3	4	4	--	--	HELIX RETAINER
8	4200781	2.5	3.7	3.7	--	--	SHELF DIVIDER
9	†4060481	6	6	6	--	--	SPRING CUP
10	†8370998	6	6	6	--	--	SPACER SUPPORT
11	†8370660-5	3	3	3	--	--	SPACER
12	4034342	3.6	4.8	4.8	--	--	MOTOR
13	8800636	6.12	8.16	8.16	--	--	#8-18x1/2 PHIL. PH TYP-B
14	4060130	3	4	4	--	--	PRESS CLR. 1/4"
--	1210560-003	1	--	--	--	--	COMPLETE SHELF ASSY.
--	1210560-002	--	1	1	--	--	COMPLETE SHELF ASSY.
15	1200155-002	1	--	--	--	--	WELD ASSY. - SHELF
"	1200154-002	--	1	1	--	--	WELD ASSY. - SHELF
16	1211083	1	1	1	--	--	RIVET ASSY. - SHELF BOTTOM
17	4050667	4	4	4	--	--	RIVET
18	4003027-000	1	1	1	--	--	LOAD REST SPACER
"	4003027-001	1	1	1	--	--	LOAD REST SPACER
19	4034390	1	--	--	--	--	SHELF HARNESS
"	4034394	--	1	1	--	--	SHELF HARNESS
20	8800636	2	2	2	--	--	#8-18x1/2 PHIL. PH TYP-B
21	4060496	2	2	2	--	--	1/4-20 NUT UNI-TORQUE
22	4060670-001	2	2	2	--	--	ROLLER
23	1200321-001	1	1	1	--	--	SIDE RAIL ASSY.
24	1200321-000	1	1	1	--	--	SIDE RAIL ASSY.
25	4025746	3	4	4	--	--	LABEL HOLDER - SNACK
26	4050792	6	8	8	--	--	#10-16x1/2 PHIL. PH TYP-B
27	4025744	3	4	4	--	--	LABEL HOLDER - CANDY
28	8800636	6	8	8	--	--	#8-18x1/2 PHIL. PH TYP-B
29	4020838	2	2	2	--	--	LABELS - SELECTION
30	4020840	2	2	2	--	--	PRICE LABEL 10-1.50
"	4020841	1	1	1	--	--	PRICE LABEL 1.50-3.15

A/C = AIR CONDITIONED † = NOT INCLUDED IN TRAY ASSEMBLY

PLASTIC TRAY ASSEMBLY

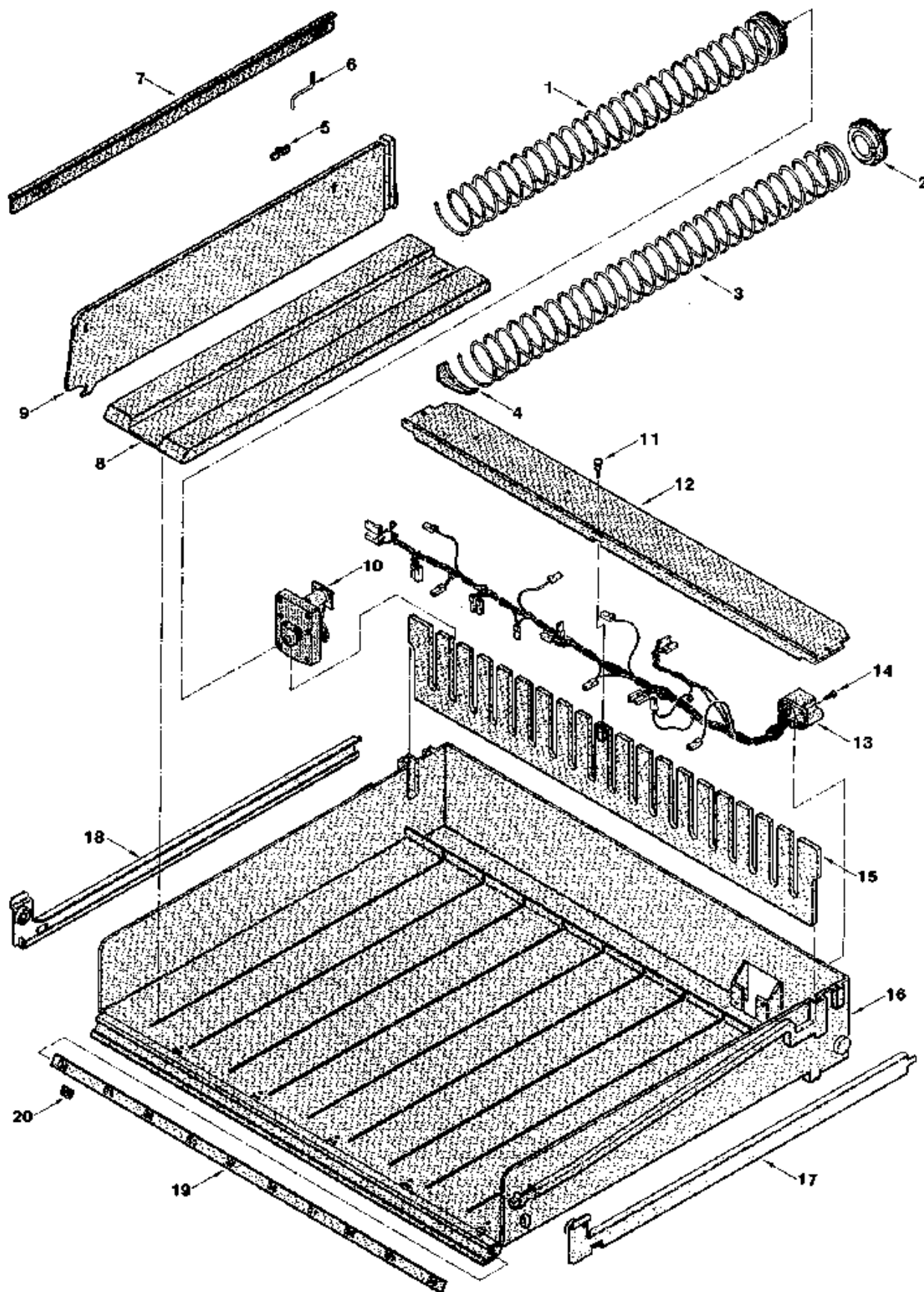

PLASTIC TRAY ASSEMBLY

ITEM	PART NUMBER	3 WIDE	4 WIDE	4 WIDE A/C	5 WIDE	5 WIDE A/C	DESCRIPTION
NUMBER PER TRAY							
--	1210924-001	--	--	--	1	1	TRAY ASSY. (10 CT.)
--	1210924-002	--	--	--	1	1	TRAY ASSY. (12 CT.)
--	1210924-003	--	--	--	1	1	TRAY ASSY. (12/15 CT.)
--	1210924-004	--	--	--	1	1	TRAY ASSY. (18 CT.)
--	1210924-005	--	--	--	1	1	TRAY ASSY. (15/18/24 CT.)
1	1200106-000	--	--	--	10	10	AUGER ASSY. 15 SEL. CANDY
*	1200106-001	--	--	--	10	10	AUGER ASSY. 18 SEL. CANDY
*	1200106-002	--	--	--	10	10	AUGER ASSY. 24 SEL. CANDY
*	1200106-003	--	--	--	10	10	AUGER ASSY. 30 SEL. CANDY
*	1200106-004	--	--	--	10	10	AUGER ASSY. 12 SEL. CANDY
*	1200106-005	--	--	--	10	10	AUGER ASSY. 9 SEL. CANDY
*	1200106-006	--	--	--	10	10	AUGER ASSY. 6 SEL. CANDY
*	1200106-007	--	--	--	5	5	AUGER ASSY. 10 SEL. SNACK
*	1200106-008	--	--	--	5	5	AUGER ASSY. 12 SEL. SNACK
*	1200106-009	--	--	--	5	5	AUGER ASSY. 15 SEL. SNACK
*	1200106-010	--	--	--	5	5	AUGER ASSY. 7 SEL. SNACK
*	1200106-011	--	--	--	5	5	AUGER ASSY. 8 SEL. SNACK
2	1211065	--	--	--	5, 10	5, 10	AUGER HUB ASSY.
3	4200272-000	--	--	--	10	10	AUGER 15 SEL. CANDY
"	4200272-001	--	--	--	10	10	AUGER 18 SEL. CANDY
*	4200272-002	--	--	--	10	10	AUGER 24 SEL. CANDY
*	4200272-003	--	--	--	10	10	AUGER 30 SEL. CANDY
*	4200272-004	--	--	--	10	10	AUGER 12 SEL. CANDY
*	4200272-005	--	--	--	10	10	AUGER 9 SEL. CANDY
*	4200272-006	--	--	--	10	10	AUGER 6 SEL. CANDY
*	4200272-007	--	--	--	5	5	AUGER 10 SEL. SNACK
*	4200272-008	--	--	--	5	5	AUGER 12 SEL. SNACK
*	4200272-009	--	--	--	5	5	AUGER 15 SEL. SNACK
*	4200272-010	--	--	--	5	5	AUGER 7 SEL. SNACK
*	4200272-011	--	--	--	5	5	AUGER 8 SEL. SNACK
4	4025748	--	--	--	5, 10	5, 10	PRODUCT EJECTOR
5	†4200281	--	--	--	6	6	SPRING CLIP
6	†8370998	--	--	--	6	6	SPACER SUPPORT
7	†8370660-5	--	--	--	3	3	SPACER
8	4200340	--	--	--	5	5	HELIX RETAINER
9	4025797	--	--	--	4, 9	4, 9	DIVIDER
10	4034388	--	--	--	5, 10	5, 10	AUGER MOTOR
*	1210542	--	--	--	1	1	COMPLETE SHELF ASSY.
11	8045133	--	--	--	3	3	#8-32x3/8 THUMB SCREW
12	4025802-001	--	--	--	1	1	MOTOR COVER
13	4034371-2	--	--	--	1	1	HARNASS
14	8800636	--	--	--	2	2	#8-18x1/2 PHIL. PH. TYP.#8
15	4025799	--	--	--	1	1	MOTOR MOUNTING PLATE
16	1211066	--	--	--	1	1	SHELF-LABEL HOLDER ASSY.
17	1200321-001	--	--	--	1	1	SIDE RAIL RIVET ASSY.
18	1200321-000	--	--	--	1	1	SIDE RAIL RIVET ASSY.
19	†4201209-001	--	--	--	1	1	SELECTION STRIP "A"
"	†4201209-002	--	--	--	1	1	SELECTION STRIP "B"
*	†4201209-003	--	--	--	1	1	SELECTION STRIP "C"
*	†4201209-004	--	--	--	1	1	SELECTION STRIP "D"
*	†4201209-005	--	--	--	1	1	SELECTION STRIP "E"
*	†4201209-006	--	--	--	1	1	SELECTION STRIP "F"
*	†4201209-007	--	--	--	1	1	SELECTION STRIP "G"
*	†4201209-008	--	--	--	1	1	SELECTION STRIP "H"
*	†4201209-009	--	--	--	1	1	SELECTION STRIP "J"
20	4200051	--	--	--	1	1	PRICE LABEL 1.50-3.15
*	4200052	--	--	--	2	2	PRICE LABEL 10-1.50

A/C = AIR CONDITIONED † = NOT INCLUDED IN TRAY ASSY.

MICROWAVE PRODUCT ASSEMBLY

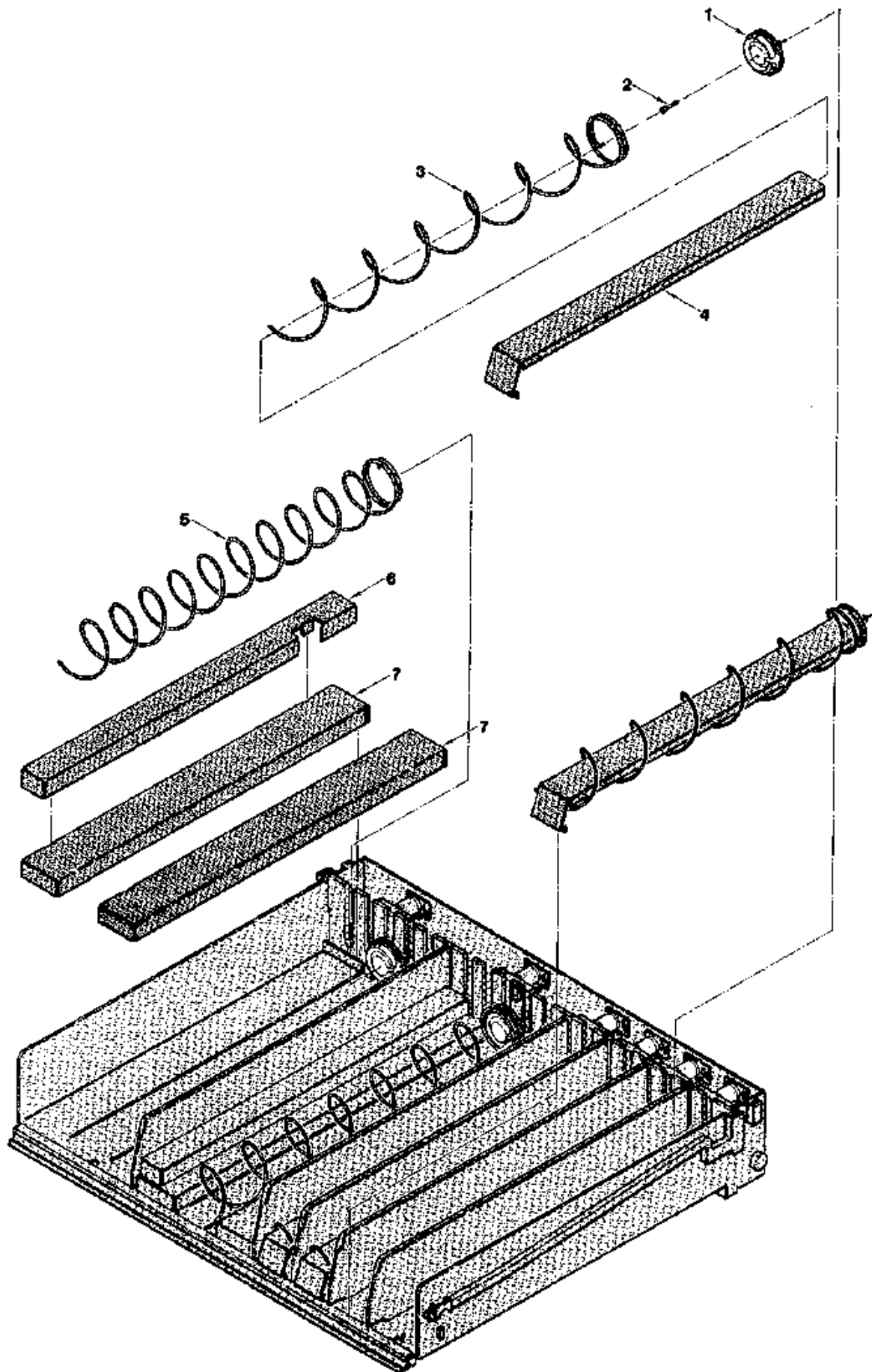

MICROWAVE PRODUCT ASSEMBLY

ITEM	PART NUMBER	3 WIDE	4 WIDE	4 WIDE A/C	5 WIDE	5 WIDE A/C	DESCRIPTION
-	1200137-098	-	-	-	-	-	LUNCH BUCKET KIT 6 SELECT
1	1211065-001	-	-	-	1	1	HUB ASSY
2	8810019	-	--	--	1	1	#10-13x3/4 WOOD SCREW
3	4200272-006	-	-	--	1	1	AUGER 6 SELECT
4	4201946	-	-	-	1	1	PRODUCT TRAY SPACER
-	1200137-097	-	-	-	-	-	WIDE PRODUCT KIT 7 SELECT
5	4200272-010	-	--	--	1	1	AUGER 7 SELECT
6	4201939	-	--	--	1	1	PRODUCT TRAY SPACER
7	4201929	-	--	--	2	2	PRODUCT TRAY SPACER
-	1200137-096	-	-	-	-	-	WIDE PRODUCT KIT 10 SELECT
5	4200272-007	-	-	--	1	1	AUGER 10 SELECT
6	4201939	-	--	--	1	1	PRODUCT TRAY SPACER
7	4201929	-	-	--	2	2	PRODUCT TRAY SPACER

A/C = AIR CONDITIONED

COMPLETE CONTROL PANEL ASSEMBLY

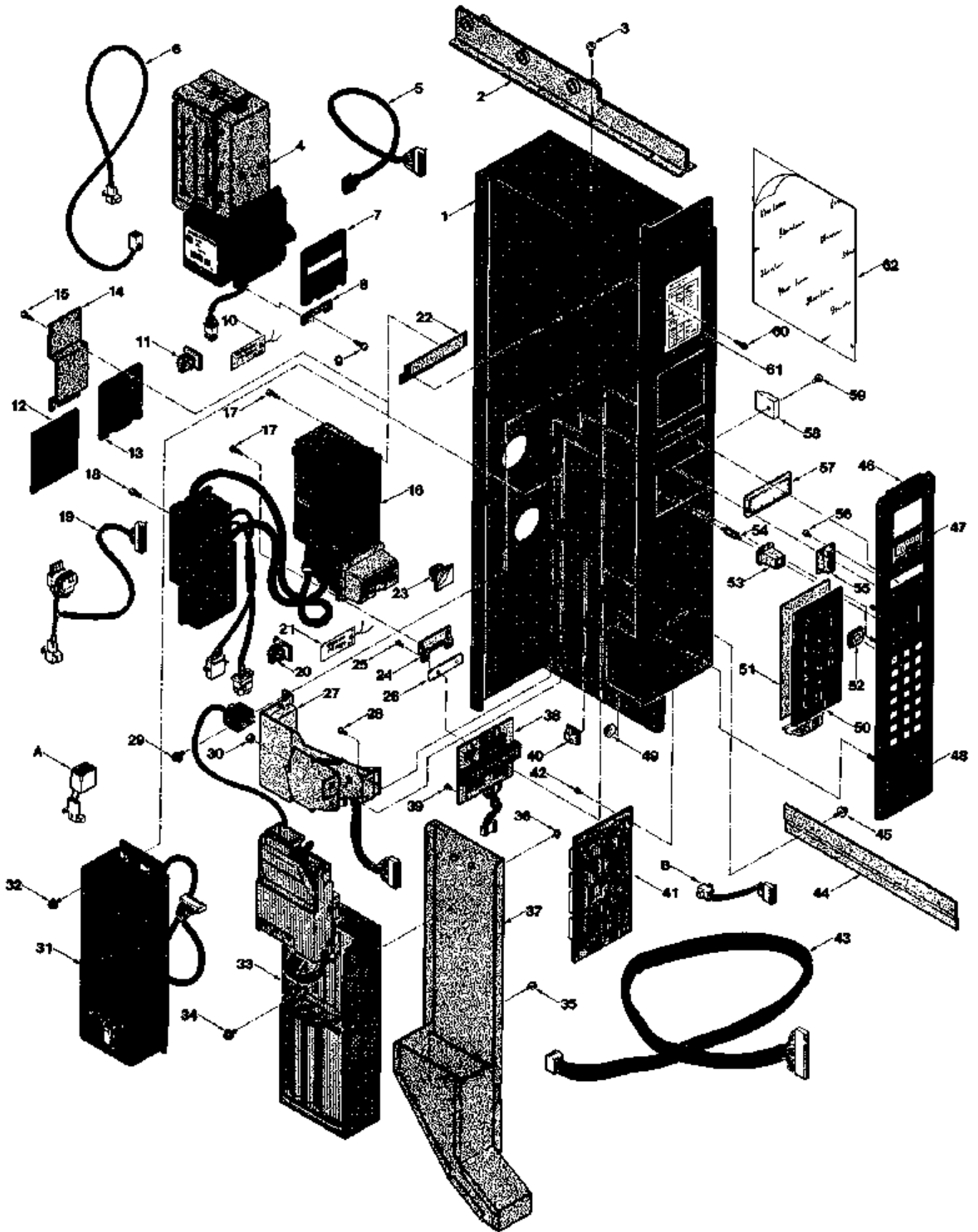

COMPLETE CONTROL PANEL ASSEMBLY

ITEM	PART NUMBER	3 WIDE	4 WIDE	4 WIDE A/C	5 WIDE	5 WIDE A/C	DESCRIPTION
--	1210852	1	1	--	1	--	CONTROL PANEL ASSY.
--	1210969	--	--	1	--	1	CONTROL PANEL ASSY.
--	*1210874	1	1	--	1	--	CONTROL PANEL ASSY.
--	*1210944	--	--	1	--	1	CONTROL PANEL ASSY.
1	1210767-002	1	1	1	1	1	CONTROL PANEL WELD ASSY.
2	1210796	1	1	1	1	1	CONTROL PANEL RAIL STAKE
3	4050792	6	6	6	6	6	#10-16x1/2 PHIL PH TYP-B
4	+▲1210752-002	1	1	1	1	1	MARS VALIDATOR PKG. (400)
5	+▲4200315	1	1	1	1	1	VALIDATOR-MARS
5	▲4200712	1	1	1	1	1	DATA HARNESS
6	▲4200708-117	1	1	1	1	1	VALIDATOR HARNESS
7	▲4025755	1	1	1	1	1	BEZEL-MARS VALIDATOR
8	▲4003038-001	1	1	1	1	1	LOWER MTG. BRKT. - MARS
9	▲8800636	4	4	4	4	4	#8-18x1/2 PHIL PH TYP-B
10	▲4020872	1	1	1	1	1	"WARNING 110 VOLTS" TAG
11	▲8370959	2	2	2	2	2	CABLE CLAMP 1/2" DIA.
12	▲4020662	1	1	1	1	1	COVER - OPR. INSTRUCTIONS
13	▲4025756	1	1	1	1	1	FILLER-VALIDATOR OPENING
14	▲4003093-002	1	1	1	1	1	FILLER-RETAINER BRKT.
15	▲8800636	4	4	4	4	4	#8-18x1/2 PHIL PH TYP-B
--	+▲1210752-001	1	1	1	1	1	MAKA VALIDATOR PKG. (400)
16	+▲4034401	1	1	1	1	1	VALIDATOR-MAKA
17	▲8800636	4	4	4	4	4	#8-18x1/2 PHIL PH TYP-B
18	▲4050792	2	2	2	2	2	#10-16x1/2 PHIL PH TYP-B
19	▲4200704-117	1	1	1	1	1	HARNESS
20	▲8370959-3	2	2	2	2	2	CABLE CLAMP 3/4" DIA.
21	▲4020872	1	1	1	1	1	"WARNING 110 VOLTS" TAG
22	▲4003100-002	1	1	1	1	1	VALIDATOR MTG. BRKT.
23	8370959-3	1	1	1	1	1	CABLE CLAMP 3/4" DIA.
24	▲4003094-002	1	1	1	1	1	LOWER MTG. BRKT. - MAKA
25	4050423	2	2	2	2	2	#8-18x3/8 PHIL PH TYP-AB
26	4200717	1	1	1	1	1	INSULATOR
27	1211049	1	1	1	1	1	COIN INSERT ASSY. (PG. 27)
27	*1211062	1	1	1	1	1	COIN INSERT ASSY. (PG. 27)
28	4050423	2	2	2	2	2	#8-18x3/8 PHIL PH TYP-AB
29	4050420	2	2	2	2	2	#8-18x1/4 PHIL HWH TYP-B
30	4050496	1	1	1	1	1	1/4x20 HEX NUT UNITORQUE
31	1210853	1	1	1	1	1	TRANS BOX ASSY. (PG. 27)
·	1210972	--	--	1	--	1	TRANS BOX ASSY. (PG. 27)
·	*1210872	1	1	1	1	1	TRANS BOX ASSY. (PG. 27)
A	*4200709	1	1	1	1	1	POWER HARNESS
32	4050420	2	2	2	2	2	#8-18x1/4 PHIL HWH TYP-B
33	4200732	1	1	1	1	1	COIN MECH. - MARS TRC6010
·	4200419	1	1	1	1	1	COIN MECH. - COINCO 9302L
34	4050420	1	1	1	1	1	#8-18x1/4 PHIL HWH TYP-B
35	4050420	2	2	2	2	2	#8-18x1/4 PHIL HWH TYP-B
36	4050420	2	2	2	2	2	#8-18x1/4 PHIL HWH TYP-B
37	1210805-002	1	1	1	1	1	COIN MECH. PLATE WELD
38	4200660	1	1	1	1	1	READ OUT
39	4050120	2	2	2	2	2	#6-32x5/16 PHIL PH TYP-T
40	4200238	1	1	1	1	1	SELF ADHESIVE FEET
41	4201042	1	1	1	1	1	CONTROL BOARD
B	*4200705	1	1	1	1	1	DATA HARNESS
42	4050120	4	4	4	4	4	#6-32x5/16 PHIL PH TYP-T
43	4200691	1	1	1	1	1	POWER PANEL HARNESS
44	4201258-004	1	1	1	1	1	CONTROL PANEL GUIDE
45	4050420	4	4	4	4	4	#8-18x1/4 PHIL HWH TYP-B
46	4201199-001	1	1	1	1	1	SELECTOR PANEL
47	4020876	1	1	1	1	1	BILL INSERT LABEL
48	4020855-000	1	1	1	1	1	LABEL INSTRUCTIONS
49	4050747	6	6	6	6	6	1/4 STAMPED HEX NUT
50	4201202	1	1	1	1	1	KEY PAD
51	4003193	1	1	1	1	1	BACK PLATE - KEY PAD
52	4025741	21	21	21	21	21	PUSH BUTTON
53	4025750	1	1	1	1	1	BUTTON - COIN RETURN
54	4050488-001	1	1	1	1	1	ROD - COIN RETURN
55	4025752	1	1	1	1	1	COIN INSERT MOLDING
56	4050120	2	2	2	2	2	#6-32x5/16 SCREW
57	4200659	1	1	1	1	1	READ-OUT WINDOW
58	4025610	1	1	1	1	1	DOOR GLIDE
59	4050239	1	1	1	1	1	#8-32x3/8 PHIL PH TYP-T
60	8800636	1	1	1	1	1	#8-18x1/2 PHIL PH TYP-B
61	4201661	1	1	1	1	1	CONTROL BOARD INSTRUCTIONS
62	4201554	1	1	1	1	1	SCHEMATIC

COMPLETE COIN INSERT ASSEMBLY & COMPLETE TRANSFORMER BOX ASSEMBLY

A

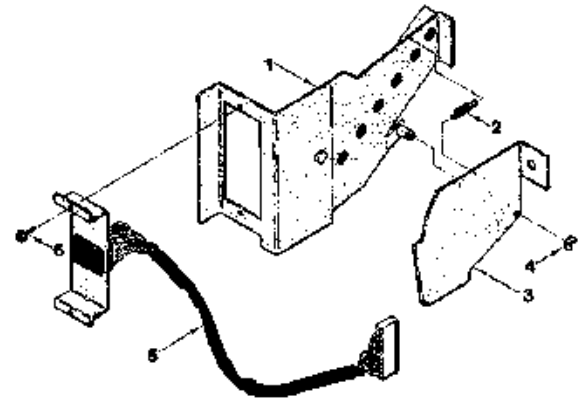

B

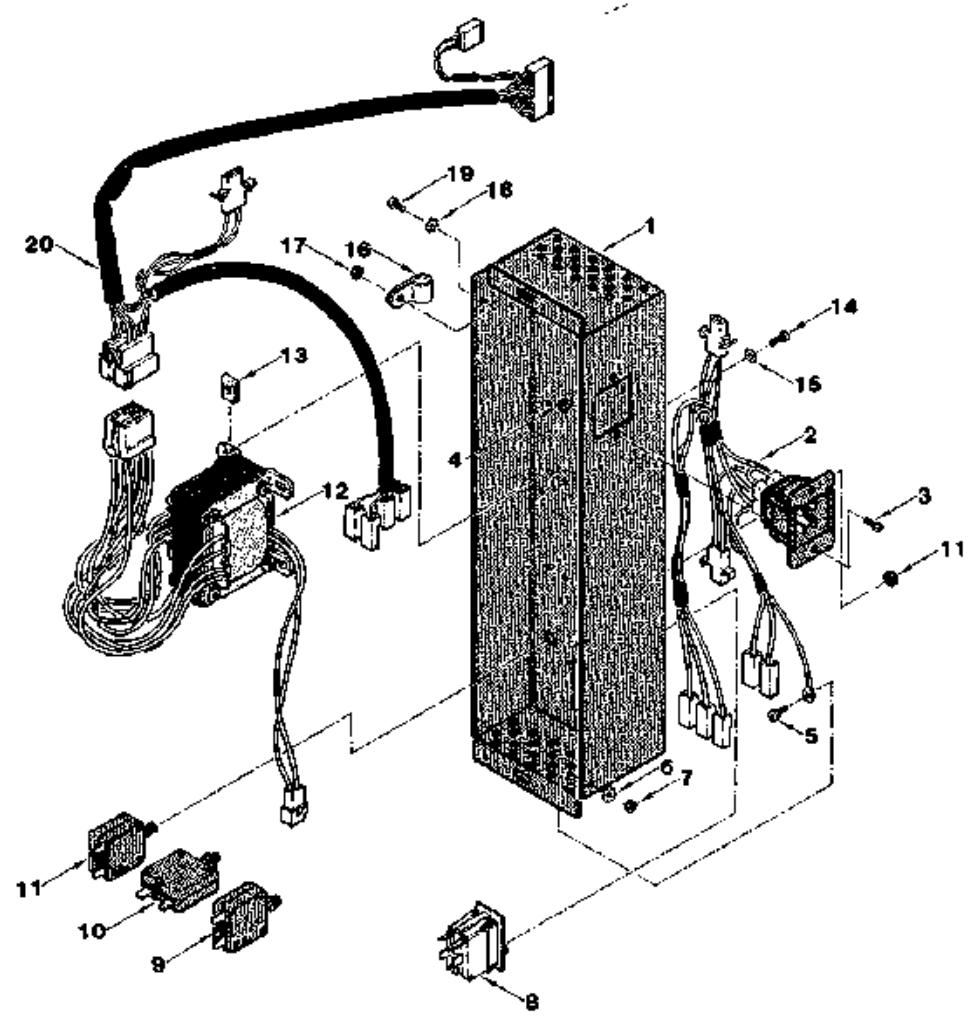

COMPLETE COIN INSERT ASSEMBLY & COMPLETE TRANSFORMER BOX ASSEMBLY

A ITEM	PART NUMBER	3 WIDE	4 WIDE	4 WIDE A/C	5 WIDE	5 WIDE A/C	DESCRIPTION
-	1211049	1	1	1	1	1	COMPLETE COIN INSERT ASSY.
-	*1211062	1	1	1	1	1	COMPLETE COIN INSERT ASSY.
1	1210769-002	1	1	1	1	1	COIN INSERT WELD
2	4021020	1	1	1	1	1	SPRING
3	4201300-002	1	1	1	1	1	COIN RELEASE ARM
4	8801077	1	1	1	1	1	E-RING
5	1210507	1	1	1	1	1	COIN MECH. HARNESS ASSY.
6	4050202	2	2	2	2	2	#8-18x1/2 TEK SCREW

A/C = AIR CONDITIONED

* = 220-240 VOLTAGE USE ONLY

B ITEM	PART NUMBER	3 WIDE	4 WIDE	4 WIDE A/C	5 WIDE	5 WIDE A/C	DESCRIPTION
-	1210853	1	1	1	1	1	TRANSFORMER BOX ASSY.
-	1210972	1	1	1	1	1	TRANSFORMER BOX ASSY.
-	*1210872	1	1	1	1	1	TRANSFORMER BOX ASSY.
1	4201556-002	1	1	1	1	1	TRANSFORMER HOUSING - BLK.
2	4201546	1	1	1	1	1	POWER PANEL HARNESS
3	4050240	2	2	2	2	2	#8-32x3/8 PHIL PH MS
4	4050513	2	2	2	2	2	#8-32 TWIN WHIZ LOCKNUT
5	4050240	1	1	1	1	1	#8-32x3/8 PHIL PH MS
6	4050585	1	1	1	1	1	#8 EXT. TOOTH LOCKWASHER
7	4050513	1	1	1	1	1	#8-32 TWIN WHIZ LOCKNUT
8	4200734	1	1	1	1	1	ROCKER SWITCH
9	4033620	1	1	1	1	1	CIRCUIT BREAKER/5 AMP
10	8379259-3	1	1	1	1	1	CIRCUIT BREAKER/10 AMP
11	4033071	1	1	1	1	1	CIRCUIT BREAKER/3 AMP
12	4033488	1	1	1	1	1	CIRCUIT BREAKER/1 1/2 AMP
13	1200323	1	1	1	1	1	TRANSFORMER ASSY.
14	*4201526	1	1	1	1	1	TRANSFORMER ASSY.
15	4050595-001	4	4	4	4	4	J-TYPE SPEED NUT
16	8800636	4	4	4	4	4	#8-18x1/2 PHIL PH TYP-B
17	4050585	1	1	1	1	1	#8 EXT. TOOTH LOCKWASHER
18	4060116	1	1	1	1	1	PLASTIC WIRE CLAMP 3/8"
19	4050513	1	1	1	1	1	#8-32 TWIN WHIZ LOCKNUT
20	4050585	1	1	1	1	1	#8 EXT. TOOTH LOCKWASHER
21	4050240	1	1	1	1	1	#8-32x3/8 PHIL PH MS
22	4200700	1	1	1	1	1	SECONDARY HARNESS

A/C = AIR CONDITIONED

* = 220-240 VOLTAGE USE ONLY

COMMON AIR CONDITIONED CABINET ASSEMBLY

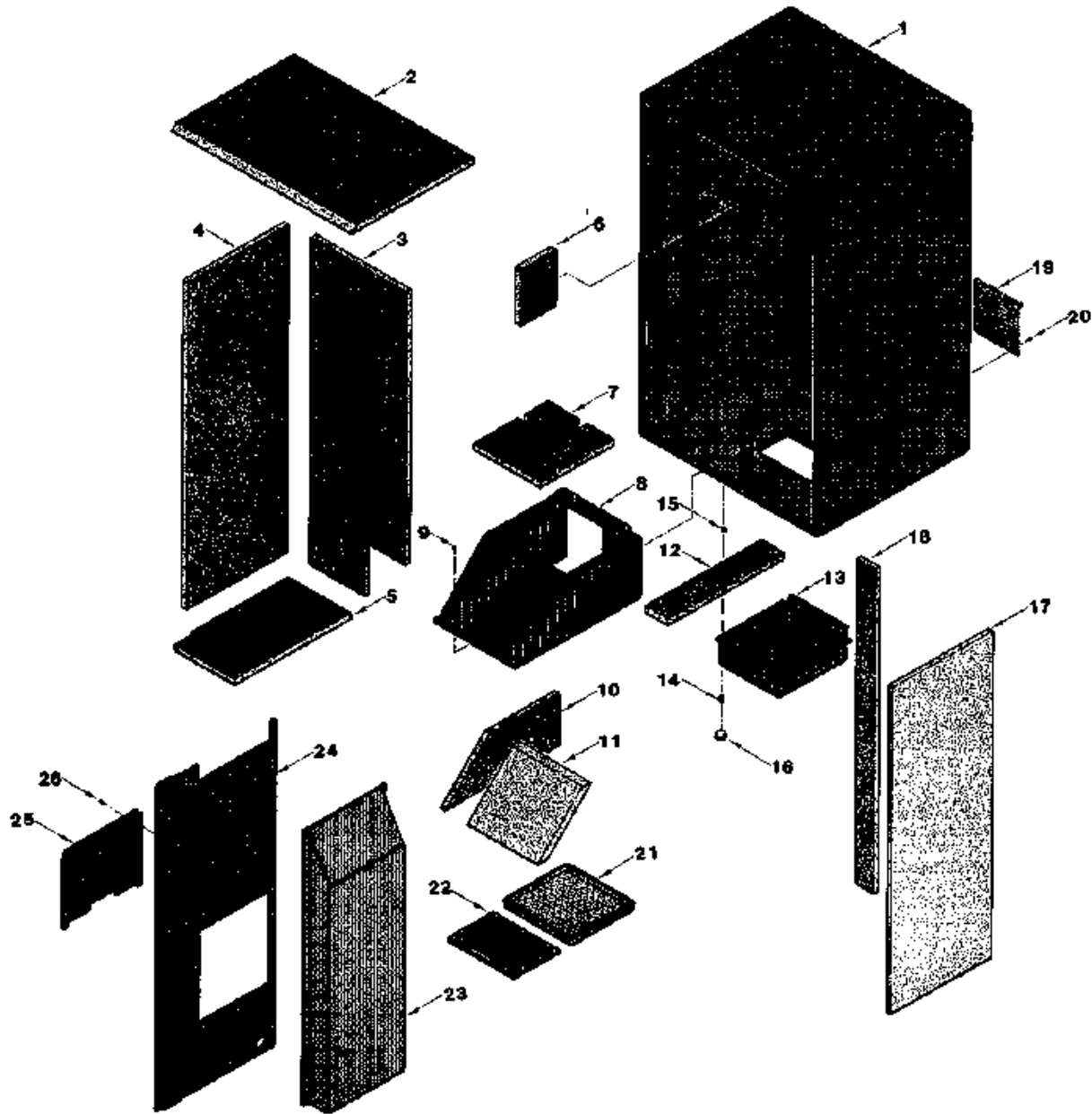

COMMON AIR CONDITIONED CABINET ASSEMBLY

ITEM	PART NUMBER	3 WIDE	4 WIDE	4 WIDE A/C	5 WIDE	5 WIDE A/C	DESCRIPTION
1	1210930-004	-	-	1	-	-	GABINET WELD ASSY
	1210930-005	-	-	1	-	-	GABINET WELD ASSY
2	4201644-001	-	--	1	--	--	INSULATION PANEL - TOP
	4201644	--	--	--	--	1	INSULATION PANEL - TOP
3	4201647-001	-	-	1	-	-	INSULATION PANEL - REAR LEFT
	4201647	-	-	1	-	-	INSULATION PANEL - REAR LEFT
4	4201648	-	-	1	-	-	INSULATION PANEL - LEFT SIDE
5	4201641-001	-	-	1	-	-	INSULATION PANEL - BOT. LEFT
	4201641	-	-	1	-	-	INSULATION PANEL - BOT. LEFT
6	4201639-002	-	-	12	-	-	INSULATION - LEFT SUPPORT
7	4201645	--	--	1	--	1	INSULATION PANEL - DUCT TOP
	1210945	-	-	1	-	-	WARM AIR DUCT INSTALLATION
8	1210918-002	-	-	1	-	-	WARM AIR DUCT WELD ASSY
9	4050180	-	-	4	-	-	#8-18x1/2 PHIL PH TEK
10	4201642	--	--	2	--	2	INSULATION PANEL - DUCT SD
11	4201643	--	--	1	--	1	INSULATION PANEL - DUCT FR
12	4201640	-	-	1	-	-	INSULATION PANEL - BOT. RIGHT
	1210955	-	-	1	-	-	WARM AIR SCOOP ASSY
13	4201689-003	--	--	1	--	1	WARM AIR SCOOP
14	4050780	--	--	2	--	2	NYLATCH PLUNGER
15	4050779	--	--	2	--	2	NYLATCH GROMMET
16	7250135-006	--	--	2	--	2	1/4 HOLE PLUG
17	4201646	--	--	1	--	1	INSULATION PANEL - RIGHT SIDE
18	4201649	--	--	1	--	1	INSULATION PANEL - RIGHT REAR
19	4201222-004	--	--	1	--	1	GABINET SCREEN/BLACK
20	4050180	--	--	2	--	2	#8-18x1/2 PHIL PH TEK
21	4201629	--	--	1	--	1	BOTTOM DRAIN PAN
22	8363509-1	--	--	1	--	1	SCREEN
23	4201633	--	--	1	--	1	COOL AIR DUCT
24	4201677-002	--	--	1	--	1	PARTITION PANEL/BLACK
25	4201662-002	--	--	1	--	1	PARTITION COVER
26	4050180	--	--	4	--	4	#8-18x1/2 PHIL PH TEK

A/C = AIR CONDITIONED

COMPLETE AIR CONDITIONING UNIT

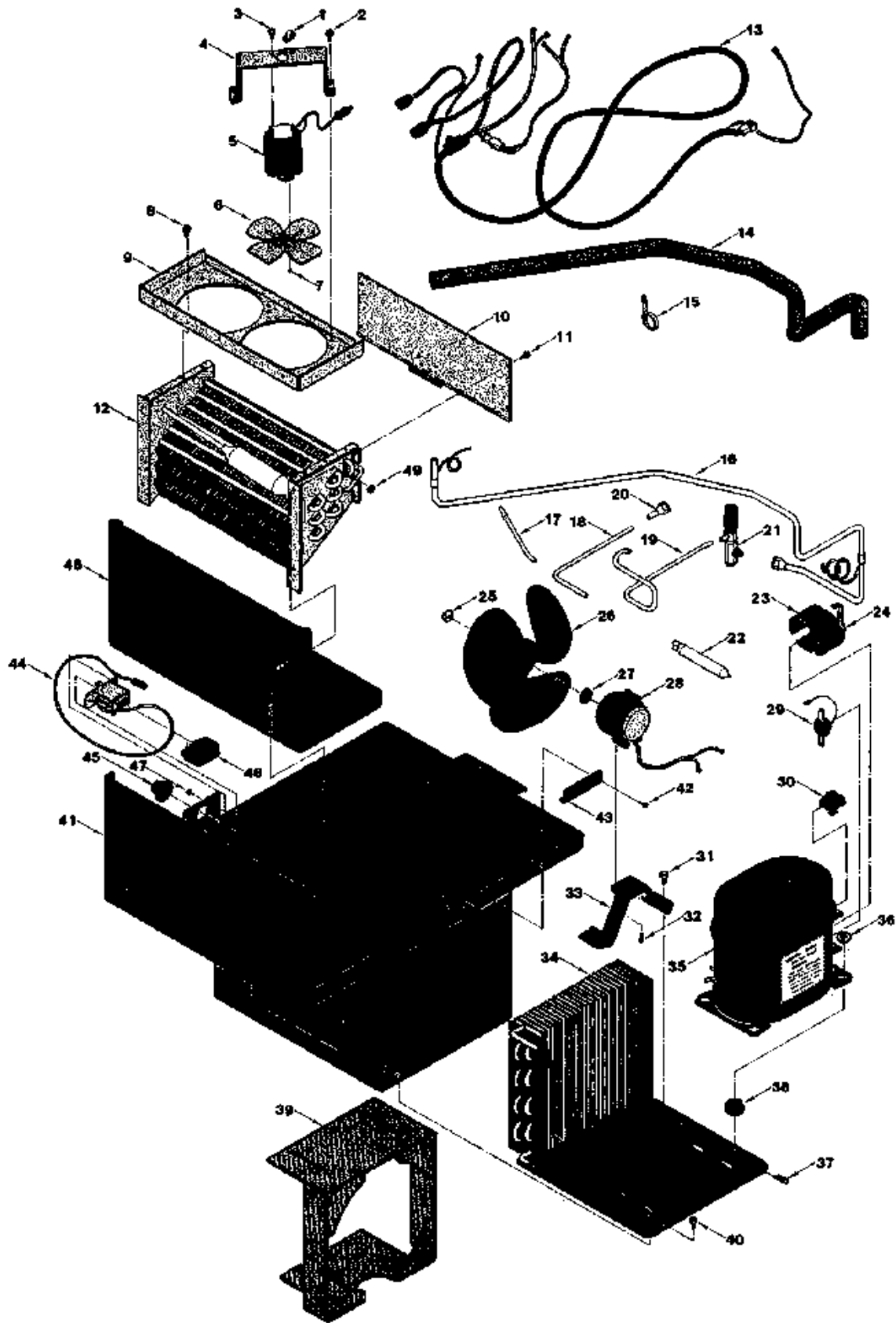

COMPLETE AIR CONDITIONING UNIT

ITEM	PART NUMBER	3 WIDE	4 WIDE	4 WIDE A/C	5 WIDE	5 WIDE A/C	DESCRIPTION
-	1210970	-	-	1	-	1	COMPLETE REFRIGERATION UNIT
-	*1210949	-	-	1	-	1	COMPLETE REFRIGERATION UNIT
1	4060116	-	-	1	-	1	PLASTIC WIRE CLAMP
-	1210971	-	-	1	-	1	EVAPORATOR COIL ASSY
-	*1210951	-	-	1	-	1	EVAPORATOR COIL ASSY
2	8801204	-	-	8	-	8	#10-16x3/8 PHIL TH W/ETW
-	1211075	-	-	1	-	1	EVAPORATOR FAN ASSY
-	*1211076	-	-	1	-	1	EVAPORATOR FAN ASSY
3	8800378	-	-	4	-	4	#10-32x3/8 PHIL PH MS-LW
4	8382579	-	-	2	-	2	FAN BRACKET
5	7331297-000	-	-	2	-	2	MOTOR - EVAPORATOR FAN
"	*7250309-000	-	-	2	-	2	MOTOR--220/240 V. EVAP FAN
6	4201176-001	-	-	2	-	2	FAN BLADE/ALUMINUM
7	8810012	-	-	8	-	8	#3-48x1/4 PHIL RH MS-PLD
8	8801204	-	-	6	-	6	#10-16x3/8 PHIL TH W/ETW
9	8382581	-	-	1	-	1	ORIFICE - EVAPORATOR FAN
10	1210974	-	-	1	-	1	EVAPORATOR FRONT WELD ASSY
11	8801204	-	-	4	-	4	#10-16x3/4 PHIL TH W/ETW
12	8382295	-	-	1	-	1	EVAPORATOR
13	4201700	-	-	1	-	1	REFRIGERATION HARNESS
14	8365271-3	-	-	1	-	1	INSULATION - 24"
15	4033712	-	-	5	-	5	TIE WRAP
16	1210923-002	-	-	1	-	1	HEAT EXCHANGE ASSY./FORMED
17	8801180-003	-	-	1	-	1	1/4" x 6" COPPER TUBING
18	4201671	-	-	1	-	1	DISCHARGE TUBE
19	(NASI)	-	-	1	-	1	(NASI)
20	4201695-001	-	-	2	-	2	3/8 DOUBLE FLARE
21	(NASI)	-	-	1	-	1	(NASI)
22	7189453-000	-	-	1	-	1	DRIER
-	1210907-003	-	-	1	-	1	CONDENSING UNIT 100/115 VOLT
-	*1210907-004	-	-	1	-	1	CONDENSING UNIT 220/240 VOLT
23	8344308	-	-	1	-	1	COVER - TERMINAL
24	8344306	-	-	1	-	1	BALE STRAP
25	4201876	-	-	1	-	1	BLADE NUT
26	4201875	-	-	1	-	1	FAN BLADE
27	4201879	-	-	1	-	1	MOTOR GASKET
28	4201877	-	-	1	-	1	CONDENSOR MOTOR
"	*4201878	-	-	1	-	1	CONDENSOR MOTOR
29	4201880	-	-	1	-	1	OVERLOAD
"	*4201881	-	-	1	-	1	220/240 VOLT OVERLOAD
30	4201882	-	-	1	-	1	RELAY
"	*4201883	-	-	1	-	1	220/240 VOLT RELAY
31	(NASI)	-	-	4	-	4	(NASI)
32	(NASI)	-	-	4	-	4	(NASI)
33	(NASI)	-	-	1	-	1	(NASI)
34	(NASI)	-	-	1	-	1	(NASI)
35	4201884	-	-	1	-	1	COMPRESSOR
"	*4201885	-	-	1	-	1	220/240 VOLT COMPRESSOR
36	(NASI)	-	-	4	-	4	(NASI)
37	(NASI)	-	-	4	-	4	(NASI)
38	8323090-1	-	-	4	-	4	GROMMET - COMPRESSOR
39	(NASI)	-	-	1	-	1	(NASI)
40	4050373	-	-	2	-	2	1/4-20x1/2 PHIL PH TAPTITE
41	1210916-002	-	-	1	-	1	COMPLETE CONDENSOR MIG WELD
42	4050226	-	-	2	-	2	#8-32x1/4 PHIL TH TAPTITE
43	4201674-002	-	-	1	-	1	STRAP - TOP PANEL
44	4034324-001	-	-	1	-	1	THERMOSTAT
45	4201707	-	-	1	-	1	KNOB - THERMOSTAT
46	4201664	-	-	1	-	1	TEMPERATURE CONTROL COVER
47	8800083	-	-	2	-	2	#8-32x1/2 PHIL PH MS
48	4201631	-	-	1	-	1	TOP DRAIN PAN
49	4050496	-	-	4	-	4	1/4-20 NUT UNI TORQUE

A/C = AIR CONDITIONED * = 220-240 VOLTAGE USE ONLY (NASI) = NOT A SERVICE ITEM

FINAL ASSEMBLY

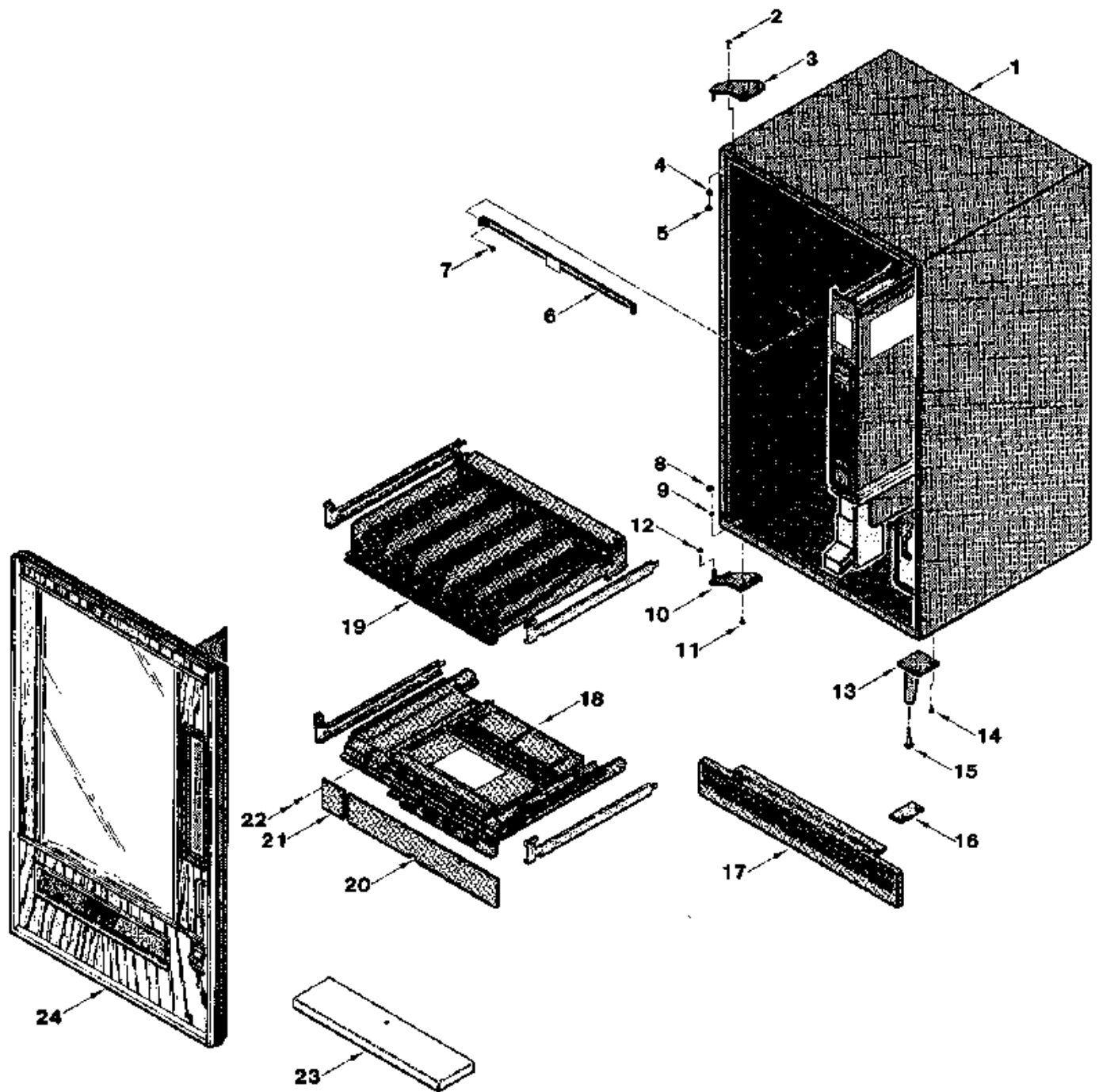

FINAL ASSEMBLY

ITEM	PART NUMBER	3 WIDE	4 WIDE	4 WIDE A/C	5 WIDE	5 WIDE A/C	DESCRIPTION
1	1210728-003	1	1	1	1	1	COMMON CABINET ASSY.
1	1210728-004	1	1	1	1	1	COMMON CABINET ASSY.
1	1210728-005	1	1	1	1	1	COMMON CABINET ASSY.
1	1210968-004	1	1	1	1	1	COMMON CABINET ASSY.
1	1210968-005	1	1	1	1	1	COMMON CABINET ASSY.
1	*1210871-003	1	1	1	1	1	COMMON CABINET ASSY.
1	*1210871-004	1	1	1	1	1	COMMON CABINET ASSY.
1	*1210871-005	1	1	1	1	1	COMMON CABINET ASSY.
7	*1210943-004	1	1	1	1	1	COMMON CABINET ASSY.
7	*1210943-005	1	1	1	1	1	COMMON CABINET ASSY.
2	4050099	3	3	3	3	3	5/16-18x3/4 CARRIAGE BOLT
3	1210709-003	1	1	1	1	1	HINGE PLATE - TOP
4	7186148-000	3	3	3	3	3	5/16 SPLIT LOCKWASHER/PLATED
5	4050066	3	3	3	3	3	5/16-18 HEX NUT/PLATED
6	4201541-003	2	2	2	2	2	SHIPPING BRKT.
6	4201541-004	2	2	2	2	2	SHIPPING BRKT.
6	4201541-005	2	2	2	2	2	SHIPPING BRKT.
7	8810014	4	4	4	4	4	#12-18x1/2 PHIL TH TYP AB
8	4050066	3	3	3	3	3	5/16-18 HEX NUT/PLATED
9	8801018	3	3	3	3	3	5/16 FLAT WASHER
10	1210709-004	1	1	1	1	1	HINGE PLATE - BOTTOM
11	4201385	4	4	4	4	4	5/16-18x1 THREAD ROLLER
12	4201138	1	1	1	1	1	HINGE SPACER
13	1131275	4	4	4	4	4	LEG WELD/BLACK
14	4201385	12	12	12	12	12	5/16-18x1 THREAD ROLLER
15	6343374	4	4	4	4	4	LEG LEVELER
16	▲4201377-002	2	2	2	2	2	KICK PANEL MTG. BRKT.
17	▲4201380-003	1	1	1	1	1	KICK PANEL
17	▲4201380-004	1	1	1	1	1	KICK PANEL
17	▲4201380-006	1	1	1	1	1	KICK PANEL
17	▲1210808-003	1	1	1	1	1	KICK PANEL INSTALLATION
17	▲1210808-004	1	1	1	1	1	KICK PANEL INSTALLATION
17	▲1210808-006	1	1	1	1	1	KICK PANEL INSTALLATION
18	▲1210774-003	1	1	1	1	1	GUM & MINT ASSY.
18	▲1210774-004	1	1	1	1	1	GUM & MINT ASSY.
18	▲1210774-005	1	1	1	1	1	GUM & MINT ASSY.
19	1210922-001	6-8	6-8	6-8	6-8	6-8	TRAY ASSY. (10 CT. SNACK)
19	1210922-002	6-8	6-8	6-8	6-8	6-8	TRAY ASSY. (12 CT. SNACK)
19	1210922-003	6-8	6-8	6-8	6-8	6-8	TRAY ASSY. (12/15 CT. SNACK)
19	1210922-004	6-8	6-8	6-8	6-8	6-8	TRAY ASSY. (18 CT. CANDY)
19	1210922-005	6-8	6-8	6-8	6-8	6-8	TRAY ASSY. (15/18/24 CT. CANDY)
19	1210922-006	6-8	6-8	6-8	6-8	6-8	TRAY ASSY. (10 CT. SNACK)
19	1210922-007	6-8	6-8	6-8	6-8	6-8	TRAY ASSY. (12 CT. SNACK)
19	1210922-008	6-8	6-8	6-8	6-8	6-8	TRAY ASSY. (12/15 CT. SNACK)
19	1210922-009	6-8	6-8	6-8	6-8	6-8	TRAY ASSY. (18 CT. CANDY)
19	1210922-010	6-8	6-8	6-8	6-8	6-8	TRAY ASSY. (15/18/24 CT. CANDY)
19	1210924-001	6-8	6-8	6-8	6-8	6-8	TRAY ASSY. (10)
19	1210924-002	6-8	6-8	6-8	6-8	6-8	TRAY ASSY. (12)
19	1210924-003	6-8	6-8	6-8	6-8	6-8	TRAY ASSY. (12/15)
19	1210924-004	6-8	6-8	6-8	6-8	6-8	TRAY ASSY. (18)
19	1210924-005	6-8	6-8	6-8	6-8	6-8	TRAY ASSY. (15/18/24)
20	▲4201430-003	1	1	1	1	1	GUM & MINT COVER
20	▲4201430-004	1	1	1	1	1	GUM & MINT COVER
20	▲4201430-005	1	1	1	1	1	GUM & MINT COVER
21	▲4201429-003	1	1	1	1	1	GUM & MINT COVER FILLER
21	▲4201429-004	1	1	1	1	1	GUM & MINT COVER FILLER
21	▲4201429-005	1	1	1	1	1	GUM & MINT COVER FILLER
22	8800829	4	4	4	4	4	#10-24x3/8 PHIL TH W/ETW
23	▲4201194-003	1	1	1	1	1	FALSE FLOOR/WHITE
23	▲4201194-004	1	1	1	1	1	FALSE FLOOR/WHITE
23	▲4201194-005	1	1	1	1	1	FALSE FLOOR/WHITE
24	1210727-003	1	1	1	1	1	COMMON DOOR ASSY.
24	1210727-004	1	1	1	1	1	COMMON DOOR ASSY.
24	1210727-005	1	1	1	1	1	COMMON DOOR ASSY.
24	1210942-004	1	1	1	1	1	COMMON DOOR ASSY.
24	1210942-005	1	1	1	1	1	COMMON DOOR ASSY.

A/C = AIR CONDITIONED * = 220-240 VOLTAGE USE ONLY ▲ = OPTIONAL

NOTES

