

Royal Vendors, Inc.

RVV 700

Standard Programming

Operation and Service Manual



Manufactured by



Royal Vendors, Inc. • 426 Industrial Boulevard • Kearneysville WV 25430-2776 • USA
Telephone +1 304 728 8363 • Fax +1 304 725 4016 • technicalinquiry@royalvendors.com • parts@royalvendors.com • www.royalvendors.com



Royal Vendors, Inc. • 426 Industrial Boulevard • Kearneysville WV 25430-2776 • USA
Customer Service: +1 (304) 728-8363 or Toll Free 1 (800) 931-9214 • Fax +1 (304) 725-4016

E-mail: technicalinquiry@royalvendors.com
parts@royalvendors.com

Website: www.royalvendors.com

TABLE OF CONTENTS

- SAFETY SEGMENT5**

- SECTION 1: General Information and Setup7**
 - Introduction.....7
 - Unpacking the Vender and Installing It On Location7
 - Voltage Requirements and Vender’s Power Cord8
 - Programming the Vender8
 - Loading the Vender8
 - Specifications9
 - Important Note on Transporting the RVV 7009
 - Vender Identification9

- SECTION 2: Vender Component Explanation10**
 - Vender Main Controller (including pinouts)10
 - Delivery Mechanism Controller (including pinouts)13
 - Touch Pad14
 - Delivery Sensor14
 - Door Switch14
 - Liquid Crystal Display (LCD)14
 - Power Module Assembly14
 - Refrigeration System15
 - Ballast.....17
 - Credit Peripherals.....17

- SECTION 3: Vender Programming 19**
 - Internal (Service) Menu 20
 - External Menu35

- SECTION 4: Vender Maintenance 36**
 - What to Clean..... 36
 - Lubrication 36
 - Preventive Maintenance 36

- SECTION 5: Troubleshooting37**

- SECTION 6: Parts Catalog 40**

- RVV 700 Wiring Schematic70**

- CREDIT AND REPLACEMENT POLICYBack Cover**

TABLE OF CONTENTS (continued)

SAFETY SEGMENT

ROYAL VENDORS' COMMITMENT TO SAFETY

Royal Vendors is committed to safety with all of our product designs. We are committed to notifying the user of a possible danger involving the improper handling or maintenance of our venders. The servicing of any electrical or mechanical device involves **potential dangers**, both to those servicing the equipment and to users of the equipment. These dangers can occur because of improper maintenance or usage. The purpose of this safety segment is to alert everyone servicing Royal equipment of potentially dangerous areas, and to provide **basic safety guidelines** for proper upkeep.

The service manual contains various **warnings** that should be carefully read to minimize the risk of personal injury. This manual also contains service information to ensure that proper methods are followed to avoid damaging the vender or making it unsafe. It is also important to understand these **warnings** provide general guidance only. Royal could not possibly know, evaluate, or advise of all of the conceivable ways in which service might be done. Consequently, Royal cannot predict all of the possible dangerous results. These outlined safety precautions are the basis for an effective safety program. Use these safety measures, along with the service bulletins, helpful hints and product specification sheets, when installing or servicing Royal equipment.

We recommend that persons servicing our equipment maintain a similar commitment to safety. **Only personnel properly trained should have access to the interior of the vender.** This will minimize the potential dangers that are inherent in electrical and mechanical devices. Royal has no control over the vender once it leaves the premises. It is the owner or lessor's responsibility to maintain the vender in a safe condition. See installation insert located in the coin box of a new vender for proper installation procedures and refer to the service manual for recommended maintenance procedures. If you have any questions, please contact the Technical Services Department toll-free at 1-800-931-9214. (*Outside North America, dial +1 304-728-8363.*)

SAFETY REGULATIONS

- Read the safety segment before installation or service.
- Test for proper grounding before installing to reduce the risk of electrical shock and fire.
- Turn off or disconnect power cord from wall outlet before servicing.
- Only factory-authorized service technicians should service the vender.
- Remove any product before moving a vender.
- Use appropriate equipment when moving a vender.
- Always wear eye protection, and protect your hands, face, and body when working near the refrigeration system.
- Use only authorized replacement parts.
- Be aware of inherent dangers in rocking or tipping a vender.
- When moving the vender, care must be taken to prevent damage to the refrigerant tubing.

SECTION I: ELECTRICAL HAZARDS GENERAL ADVICE

Careless or improper handling of electrical circuits can result in injury or death. Anyone installing, repairing, loading, opening, or otherwise servicing a vender should be aware of this precaution. Apply all of the normal precautions when handling electrical circuits, such as:

- Refrigeration servicing to be performed by qualified personnel only.
- Unplug the vender before servicing.
- Replace electrical cords if there is any evidence of fraying or other damage.
- Keep all protective covers and ground wires in place.
- Plug equipment into outlets that are properly grounded and polarized (where applicable), and protected with fuses or circuit breakers of the correct size.
- All electrical connections must be dry and free of moisture before applying power.

WARNING:
ALWAYS TEST TO VERIFY PROPER GROUNDING PRIOR TO INSTALLATION IN ORDER TO REDUCE THE RISK OF ELECTRICAL SHOCK AND FIRE.

SAFETY SEGMENT

SECTION II: ELECTRICAL HAZARDS

A. Servicing with “Power Off”

For maximum safety, unplug the power cord from the wall outlet before opening the vender door. This will remove power from the equipment and avoid electrical hazards. Service personnel should remain aware of possible hazards from hot components although electrical power is off.

B. Servicing with “Power On”

Some service situations may require access with power on. Only factory-authorized service technicians should perform power-on servicing. Particular caution is required in servicing assemblies that combine electrical power and mechanical movement. Sudden movement (to escape mechanical action) can result in contact with live circuits and vice versa. It is therefore important to maintain maximum clearances from both moving parts and live circuits when servicing.

WARNINGS:

- 1. ONLY FACTORY-AUTHORIZED PERSONNEL SHOULD PERFORM SERVICING. SUCH SERVICE BY UNQUALIFIED INDIVIDUALS CAN BE DANGEROUS.**
2. LIGHTING CIRCUITS CAN BE HAZARDOUS. ALWAYS DISCONNECT VENDER FROM THE WALL OUTLET BEFORE REPLACING A BULB OR SERVICING THE VENDER IN THAT AREA.
3. NEVER USE A HOSE, PRESSURE WASHER OR ANY CLEANING METHOD THAT COULD WET ELECTRICAL COMPONENTS. SEE CLEANING SECTION OF MANUAL FOR SUGGESTED CLEANING METHODS. IF WATER CONTAMINATION OF ELECTRICAL COMPONENTS IS SUSPECTED, USE QUALIFIED ELECTRICAL TESTING EQUIPMENT AND TEST METHODS TO ASSURE THAT VENDER IS NOT A HAZARD BEFORE APPLYING POWER FOR ANY REASON.

SECTION 1: General Information and Setup

RVV 700

General Information

Introduction

This manual contains installation, operation, and service instructions for the Royal Vision Vender 700, by Royal Vendors, Inc. This manual also contains a parts catalog and electrical schematic for the RVV 700.

The RVV 700 is a microprocessor-controlled glass-front vender that permits pricing per selection from \$0.00 to \$99.95. The RVV 700 provides electronic space-to-sales programmability, and it will collect, store, and transfer MIS data fields to a hand-held computer (HHC) or on-line device through a DEX port.

Unpacking the Vender and Installing It On Location

UNWRAP THE VENDER

Unwrap the vender and remove the padding. Check for any signs of damage. If the vender is damaged, contact the carrier immediately. They will instruct you on the procedure for filing a claim.

If the vender is being stored, remove the plastic stretch wrap, cardboard cover, and styrofoam cushioning first. The plastic stretch wrap and styrofoam cushioning can adhere to the exterior of the vender over an extended period of time, damaging the vender's finish.

Note: For venders with T-handle locks, the vender's keys are located in the coin cup.

REMOVE THE SHIPPING SKID

Separate (split) each section of the shipping skid by inserting a claw hammer, crowbar, or similar device into the slot of each section to break it apart. Tilt the vender slightly to remove the separated pieces. (See Figure 1.1.)

REMOVE THE INTERIOR PACKING

Before plugging in the vender's power cord, remove the interior packing. Failure to remove this packing before plugging in the vender could result in damage to the vend mechanisms.

- Remove the packing tape which secures the case supports.
- Remove the binder clips that secure each of the two belts, located approximately in the middle of the belts' runs.

PLACING THE VENDER ON LOCATION

When placing the vender on location, allow for a minimum of 4" (10 cm) of space at the back of the vender. This will ensure proper ventilation of the refrigeration system.

To level the vender, close and latch the vender's door. Using a spirit level, adjust the four leveling legs until the top of the vender is level left-to-right and front-to-back. Make sure all leveling legs are in contact with the floor.

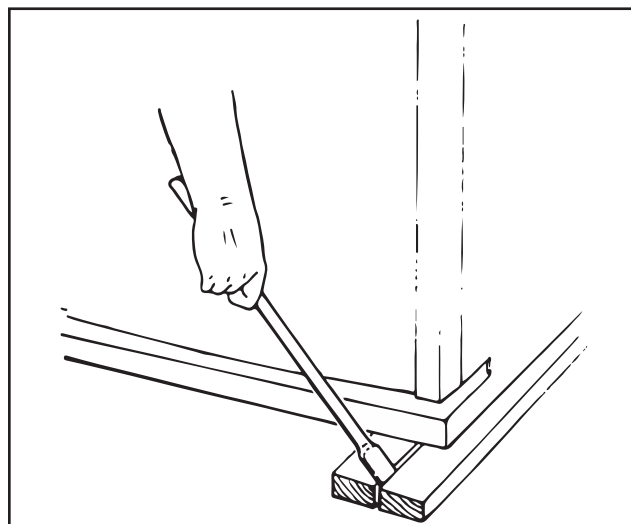

Figure 1.1

SECTION 1: General Information and Setup

Voltage Requirements and Vender's Power Cord

The vender is designed to operate at a voltage of 115 volts AC, 60 Hertz. It requires the minimum of a 15 amp service, and it should be on a dedicated circuit. The service outlet voltage must not exceed 129 VAC or fall below 103 VAC.

The vender has a three-wire grounding cord. The vender must be plugged into a grounded electrical outlet to protect customers from electrical shock. If the outlet is not equipped with a grounded socket, have one installed by a qualified electrician. Do not use an extension cord, unless it has been authorized by a certified electrician. Extension cords are not recommended.

After plugging the vender's power cord into the AC voltage source, the following should be observed:

1. The lighting system will illuminate (if the door is closed);
2. The refrigeration compressor will start to run after approximately 5-7 minutes (*with the door closed*);
3. The evaporator fan will run; and
4. The Liquid Crystal Display (LCD) will light.

The control board is equipped with a battery back-up for use in the event of a power loss. The battery is used to retain important programming information, such as space-to-sales, prices, etc., so that it will not be erased if power is lost or the vender is unplugged.

Programming the Vender

All programming of the vender is done in the Service Mode. To enter the Service Mode, open the vender's door, and press and release the Service Mode Button, located on the controller board. For programming instructions, see the section entitled "Vender Programming," later in this book.

Loading the Vender

All product should be loaded so that it is behind the front of the shelf, as shown in the illustration at right. The gate should not be folded backwards behind the product.

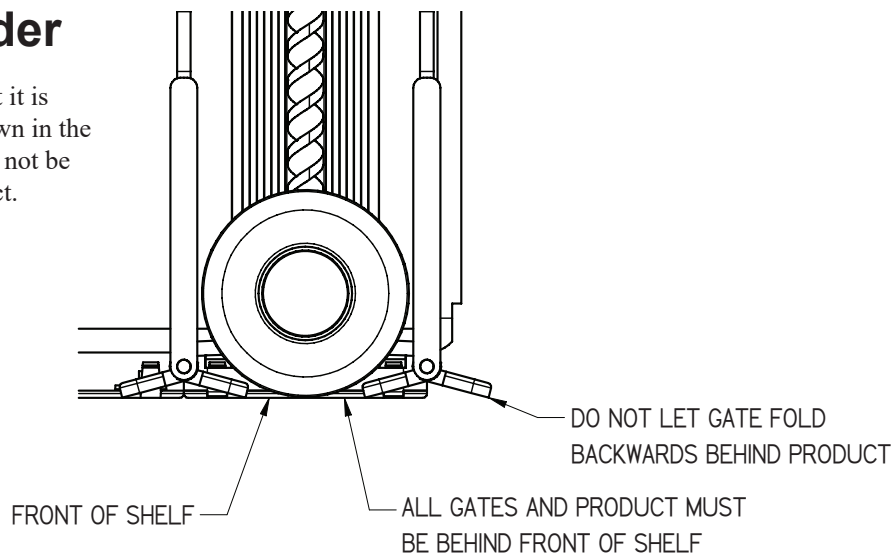

SECTION 1: General Information and Setup

RVV 700 Specifications

Dimensions72”H x 47”W x 33.25”D
(183 cm x 119 cm x 84 cm)
Approximate Empty Weight635 lbs. (288 kg)
Operating Voltage115 VAC, 60 Hz
Amperage Rating7 Amp
Charge8.0 oz. (0.23 kg)
Construction.....Steel cabinet, plastic
.....cells, glass front
Configuration50 selections (5 shelves)

IMPORTANT NOTE ON TRANSPORTING THE RVV

Before transporting the RVV 700, *always ensure that the protective transport packaging is replaced*, including:

- Packing tape to secure the case support;
- Styrofoam block on top of the motor cover, below the elevator arm;
- Binder clips to secure each belt, placed approximately in the middle of each belt’s run; and
- Cardboard to protect the glass.

Improper packaging before shipping could cause damage.

Vender Identification

VENDER SERIAL PLATE — The vender’s main serial plate is located on the exterior left side of the vender’s main door and has the following information:

- Vender model code
- Vender serial number
- Amps required by the vender
- Unit charge of R134a
- Refrigeration design pressures

The vender’s model code contains useful information: the machine type, such as RVRV3 (Royal Vendors RVV Generation III); the model number, such as 700; and the number 50, which designates that the vender has fifty cells.

The vender’s serial number contains several important pieces of information as well. The serial number currently in use consists of the following:

- The first four numbers represent the year the vender was produced;
- The fifth and sixth digits represent the week within that year the vender was produced;
- The letters represent the style of the vender; and
- The last five digits represent the number of that vender built within that week.

REFRIGERATION SERIAL PLATE: The Refrigeration Serial Plate is located on the front of the vender’s refrigeration unit, mounted on the kick plate. It looks similar to the Vender Serial Plate with the exception that the model number specified is the refrigeration unit model. There is currently one model in use:

Model	Compressor size	Usage
8000W	Super 1/3 Horsepower	All RVV 700

SECTION 2: Vender Component Explanation

Vender Component Explanation

Vender Main Controller (including pinouts)

The vender's main control board (VMC) is responsible for most vender operations. The board is protected by a cover. Removing this cover will expose the board, along with all wiring connections to the board.

IDENTIFICATION: The RVV 700's VMC can be easily identified by a Royal Vendors part number decal on the capacitor of the VMC board.

OPERATION REQUIREMENTS: The VMC requires approximately 24 and 36 volts DC from the power module assembly. This will allow the VMC to function and to supply power to all the vender's components listed below.

OPERATION: Upon receiving the appropriate voltage from the power module, the VMC issues information to some components, receives information from some components, and communicates both ways with some components.

VENDER MAIN CONTROLLER PINOUTS: The RVV 700 VMC has several electrical pinouts, a set-up mode button, and various other electronic components (all of which have designated position codes). The following section outlines all the VMC's pinouts.

The word *key* refers to the small plastic insert plugged into a position of the connector. The purpose of the key is to prevent connecting the harnessing backward or upside-down. The "keyed position" is a blank position within the pinout (no pin) in which a key is inserted. Some pinouts may have several blank positions with a key plugged into one or more of the positions. You can use the key to determine which end of the pinout is Pin 1.

DEX / UCS Connections (Position P1): The RVV 700 is equipped with a DEX / UCS jack directly on the VMC at position J1. It also has pinouts for optional three-wire harnesses leading to internal and external jacks. The Hand Held Computer (HHC) plugs into these jacks to read information from the VMC. If the vender is equipped with these optional jacks and the HHC does not operate properly with them, check the harnesses for bad connections at the solder joints. Also check to ensure that the insulator at the jack is not cracked from over tightening.

PIN NUMBER	WIRE COLOR	FUNCTION
1	RED	VMC RECEIVE / DEX TRANSMIT DATA (ring)
2	-	FUTURE USE
3	BROWN	VMC TRANSMIT / DEX RECEIVE DATA (tip)
4	-	KEY
5	BLACK	DEX COMMON (sleeve)
6	-	FUTURE USE
7	-	KEY
8	RED	VMC RECEIVE / DEX TRANSMIT DATA (ring)
9	BROWN	VMC TRANSMIT / DEX RECEIVE DATA (tip)
10	BLACK	DEX COMMON (sleeve)

SECTION 2: Vender Component Explanation

SPI Display (Position P2A): The harness connecting to this pinout travels from the vender's LCD display to the VMC. It allows the VMC to send power to and communicate with the LCD. If this harness is cut or disconnected, the LCD will go blank.

PIN NUMBER	WIRE COLOR	FUNCTION
1	WHITE	DISPLAY 24 VDC
2	RED	DISPLAY 5 VDC
3	GREY	DISPLAY
4	GREEN	DISPLAY
5	PURPLE	DISPLAY
6	YELLOW	DISPLAY
7	BLUE	DISPLAY
8	ORANGE	DISPLAY
9	BLACK	COMMON

Selection (Position P3): The RVV 700 uses a touch pad, which utilizes a matrix wiring system. Upon pressing a particular button, a signal circuit is completed. Because each output wire carries a different signal, the controller will determine which key has been pressed based on which input wire receives the output signal.

PIN NUMBER	WIRE COLOR	FUNCTION
1	BLACK	ROW 2
2	BROWN	ROW 3
3	RED	ROW 4
4	-	NC
5	-	NC
6	-	NC
7	-	NC
8	-	NC
9	-	KEY
10	ORANGE	COL 1
11	YELLOW	COL 2
12	GREEN	COL 3
13	BLUE	COL 4
14	-	NOT USED
15	-	+5VDC
16	-	GROUND

Selection / Indicator (Position P4): These pinouts may be available in the future, but at the time of this printing they are not available.

Power (Position P5): The harness connecting to this pinout comes from the electronic power supply. It is imperative the correct harness be connected to this pinout. If this harness is not connected (or if power is lost to this connection), you will noticeably lose all vender functions, including power to the LCD. The coin mechanism will not accept coins, and the refrigeration system will not run. With this connector, the wires can be in either position, and the control board will not be affected.

PIN NUMBER	WIRE COLOR	FUNCTION
1	BLACK	GROUND 4" LIGHT
2	BLACK	GROUND
3	BROWN	GROUND
4	BROWN	GROUND
5	BROWN	GROUND
6	RED	24 VDC 4" LIGHT
7	RED	24 VDC
8	GREY	36 VDC
9	GREY	36 VDC
10	GREY	36 VDC

Energy Management (Position P6): These pinouts may be available in the future, but at the time of this printing they are not available.

SECTION 2: Vender Component Explanation

Energy Management (Position P6A): The wiring harness connecting to this pinout powers the relays for refrigeration, the evaporator fan, and lighting, including brightness.

PIN NUMBER	WIRE COLOR	FUNCTION
1	RED	5 VDC
2	BLACK	COMMON
3	GREY	RELAY BOARD
4	YELLOW	RELAY BOARD
5	GREEN	RELAY BOARD
6	BLUE	RELAY BOARD
7	BROWN	RELAY BOARD
8	-	NOT USED
9	-	NOT USED
10	-	NOT USED
11	-	NOT USED
12	-	NOT USED
13	-	NOT USED
14	-	NOT USED
15	-	NOT USED
16	-	NOT USED
17	GREY	LED ILLUMINATION
18	BLACK	LED ILLUMINATION
19	GREY	LED ILLUMINATION
20	BLACK	LED ILLUMINATION

Consumer Presence (Position P6C): These pinouts may be available in the future, but at the time of this printing they are not available.

Options (Position P7): This pinout connects to an optional electronic door lock and manual override switch, as well as the door switch.

PIN NUMBER	WIRE COLOR	FUNCTION
1	-	ELECTRONIC LOCK INPUT
2	-	GROUND
3	-	NOT USED
4	-	MANUAL OVERRIDE
5	-	GROUND MANUAL OVERRIDE
6	-	NOT USED
7	BROWN	GROUND DOOR SWITCH
8	-	NOT USED
9	-	NOT USED
10	BLACK	5 VDC DOOR SWITCH
11	-	NOT USED
12	-	GROUND
13	-	NOT USED

Temperature (Position P8): The wiring harnesses connecting to this pinout travel from the temperature sensor and optional health sensor to the control board. The temperature sensor is mounted adjacent to the evaporator fan inlet. These harnesses are molded into the temperature sensor and health sensor, and they should never be cut, pinched, or spliced together if cut. If the harness is cut, pinched, or improperly grounded, the sensor may give the control board false temperature readings. Refrigeration activity is based on the signal reported to the control board from these sensors.

PIN NUMBER	WIRE COLOR	FUNCTION
1	RED	TEMP. SENSOR +5 VDC
2	WHITE	TEMP. SENSOR SIGNAL
3	-	KEY
4	BLACK	TEMP. SENSOR GROUND
5	RED	HEALTH SENSOR +5 VDC
6	WHITE	HEALTH SENSOR SIGNAL
7	-	KEY
8	BLACK	HEALTH SENSOR GROUND

SECTION 2: Vender Component Explanation

MDB (Position P9): The five-wire serial harness connecting to this pinout provides power and communications to and from the control board for the coin mechanism, the optional 24 VDC bill validator, and/or the optional debit card reader. If this harness is cut, pinched, or disconnected, you will noticeably lose power to these items.

PIN NUMBER	WIRE COLOR	FUNCTION
1	WHITE	24 VDC
2	BROWN	RETURN
3	-	NOT USED
4	BLACK	RECEIVE
5	RED	TRANSMIT
6	GREEN	COMMON

Cup (Position P10C): This harness connects to the delivery cup assembly board.

PIN NUMBER	WIRE COLOR	FUNCTION
1	BLACK	GROUND
2	BROWN	DELIVERY CUP BOARD
3	BLUE	DELIVERY CUP BOARD
4	YELLOW	DELIVERY CUP BOARD
5	PINK	DELIVERY CUP BOARD
6	GREEN	DELIVERY CUP BOARD
7	GREY	DELIVERY CUP BOARD
8	RED	5 VDC
9	WHITE	24 VDC

Port (Position P10P): The harness connecting to this pinout should never be cut, pinched, or spliced if cut. This harness controls power and communication to the port area of the vender's main door.

PIN NUMBER	WIRE COLOR	FUNCTION
1	WHITE	+24 VDC
2	ORANGE	DELIVERY BOARD SENSOR
3	BLUE	DELIVERY BOARD SENSOR
4	YELLOW	DELIVERY BOARD SENSOR
5	GREEN	DELIVERY BOARD SENSOR
6	BLACK	GROUND
7	RED	+5 VDC

X-Motor (Position P10X): The X-axis is the left and right movement of the product elevator. This pinout controls power and communication to the X-axis motor.

PIN NUMBER	WIRE COLOR	FUNCTION
1	BROWN	X-AXIS ENC GROUND
2	YELLOW	X-AXIS ENC 5VDC
3	-	NOT USED
4	WHITE	X-AXIS ENCODER CHANNEL A
5	GREEN	X-AXIS ENCODER CHANNEL B
6	-	GROUND
7	BROWN	X-AXIS PHASE B-
8	YELLOW	X-AXIS PHASE B+
9	-	NOT USED
10	-	NOT USED
11	GREEN	X-AXIS PHASE A-
12	WHITE	X-AXIS PHASE A+

Y-Motor (Position P10Y): The Y-axis is the up and down movement of the product elevator. This pinout controls power and communication to the Y-axis motor.

PIN NUMBER	WIRE COLOR	FUNCTION
1	BLACK	Y-AXIS ENC GROUND
2	RED	Y-AXIS ENC 5 VDC
3	BLUE	Y-AXIS ENCODER CHANNEL B
4	ORANGE	Y-AXIS ENCODER CHANNEL A
5	-	NOT USED
6	-	NOT USED
7	-	+5 VDC
8	BLACK	Y-AXIS PHASE A-
9	-	NOT USED
10	GREEN	Y-AXIS PHASE A+
11	-	NOT USED
12	RED	Y-AXIS PHASE B-
13	-	NOT USED
14	BLUE	Y-AXIS PHASE B+

Card Readers (Position J1 / J2): This connector interfaces with card readers when a cashless module is attached to the board at J3.

Cashless / Telemetry (Position J3): These pinouts may be available in the future, but at the time of this printing they are not available.

SECTION 2: Vender Component Explanation

Touch Pad

The 12-button touch pad is located on the right side of the door front. The touch pad contains the numbers 0-9, plus the * key and the # key. All programming and sales selections are done by way of the touch pad.

Delivery Sensor

The delivery sensor actually consists of two separate components which work in conjunction with one another. The emitter, below the product delivery port, emits an infrared beam. The receiver, above the delivery port, receives the infrared beam. When a product falls into the delivery port, the infrared beam is broken, signalling to the VMC board that a vend has been made.

Door Switch

The door switch is mounted on the vender's chassis above the vender's slide-out door. The door switch is actuated by the door each time it is opened or closed. The following functions are performed each time the vender door is closed:

1. All sold-out selections are cleared;
2. The greeting scrolls on the display;
3. If door switch reset is enabled in programming, the resettable MIS counters will be reset if at least one selection has been read;
4. A 5-7 minute delay begins after which the refrigeration unit will come on; and
5. The lighting system will turn on.

Liquid Crystal Display (LCD)

The LCD is located above the validator. All information to the programmer and to the customer is conveyed on the LCD.

Power Module Assembly

The RVV 700 uses a power module assembly which converts 115 volts AC (conventional voltage) to 24 and 36 volts DC, to power the vender's control board. The power module assembly is a major contributor to the vender's operation. Without it, the control board cannot function.

LOCATION OF ELECTRONIC POWER SUPPLY: The power supply is located in the service section of the vender. It is contained in a metal box which also holds the master power switch and the fusebox assembly.

WARNING: *Before removing this box, remove power from the vender by unplugging the main power cord from the AC voltage source (wall outlet)!*

SECTION 2: Vender Component Explanation

Refrigeration System

The vender's refrigeration system is responsible for the cooling of the cabinet and the products loaded within it. The refrigeration system comes as a completely sealed unit and should never be cut or tapped into, or the warranty will be voided.

OPERATION REQUIREMENTS

The refrigeration system requires 115 volts AC from the main wiring harness for it to operate. The main wiring harness will get its voltage for the unit from the refrigeration relay.

COOLING SOFTWARE FEATURES

The RVV 700 controller software includes the following refrigeration modes and features:

- **Normal and Pull Down Modes:** During Pull Down mode, the evaporator fan is always in high speed during ON and OFF compressor cycles. In normal mode the evaporator fan is: high speed when compressor is ON, until cut-out temperature is reached; low speed when the compressor is OFF, until cut-in temperature is reached; high speed and compressor OFF for four-minute delay after cut-in temperature is reached; then return to high speed with compressor ON. After a power failure or when the door is closed, the system starts in Pull Down Mode and a 60-minute timer starts. If Normal Mode compressor cut-out temperature is reached within this 60 minutes, the system reverts to Normal Mode; if not it will stay in Pull Down Mode. When the system running in Pull Down Mode reaches the Pull Down Mode compressor cut-out temperature, the system will continue to operate in Pull Down Mode for 50 compressor cycles, then revert to Normal Mode. Only the machine set point is adjustable by the customer. Normal and Pull Down cut-ins and cut-outs are offsets from the set point and factory set.
- **Defrost Mode:** In Pull Down Mode, there is a one-time 15-minute defrost 14 hours after start of Pull Down Mode. In Normal Mode, there is a four-minute delay for the compressor to start when Normal Mode cut-in temperature is reached. During this four-minute delay, the fan runs at high speed.

If the unit is already in the defrost mode when the door is opened, the defrost function will continue after the door is closed. Because of that, the compressor

may not restart for as much as 30 minutes after the door is closed.

- **Door Switch Inactivation Mode:** If the door switch does not activate, the fluorescent lights will stay off and the refrigeration unit will not run until 30 minutes have passed. After 30 minutes, the controller will assume that the switch may be defective and will then start the cooling process. In this mode, the evaporator fan will cycle with the refrigeration unit (similar to Normal Mode, but without the counter).
- **Compressor Motor Save Mode:** If the controller calls for cooling continuously for 24 hours, the vender will go into a defrost mode for one hour. If the refrigeration unit still does not cycle after an additional eight hours, a no pull-down error will be displayed. *Note: This no pull-down error is not self-clearing; it must be cleared manually through the service menu or through DEX.*

REFRIGERATION COMPONENTS

The refrigeration system is a sealed system. Described in this section are explanations of the refrigeration system's major components.

Capillary Tube - The capillary tube is located in the refrigerant line, between the condenser and evaporator coils. The small diameter tube is used as a metering device to control the flow of liquid refrigerant to the evaporator coil. This creates low pressure causing the refrigerant to vaporize and absorb heat as it passes through the evaporator coil.

Compressor - The compressor is a hermetically-sealed unit located beneath (outside) the cooling compartment. The compressor is a pump, driven by the compressor motor which draws low-pressure vapor (refrigerant) from the evaporator coil, compresses it, and forces it into the condenser under high pressure. The motor is started and controlled by the refrigeration relay.

Condenser - The condenser is located beneath (outside) the cooling compartment next to the compressor. It can be seen from the front with the door open. The condenser removes heat from the high-pressure vapor discharged from the compressor and condenses it to a high-pressure liquid. The condenser and evaporator coils have aluminum fins attached to effectively increase heat exchange surfaces.

Starting Relay - The starting relay is mounted on the side of the compressor housing. The compressor motor has two windings (start winding and run winding). To give the motor torque when it first starts, the starting relay switches

SECTION 2: Vender Component Explanation

in the additional start winding. After the motor gets up to speed, the relay opens the start winding and the motor continues using only the run winding.

Thermal Overload - The thermal overload is a heat-sensitive device mounted on the side of the compressor housing. If the compressor motor gets too hot or draws an excessive amount of current, the thermal overload will open, breaking the circuit to the compressor. After the compressor cools to a safe operating temperature, the thermal overload will close, allowing the compressor and condenser fan motors to restart.

Condenser Fan and Motor - The condenser fan and motor, located beneath the cooling department, are a forced-air device using outside ambient air to cool the surface of the condenser coil. The condenser fan and motor run while the compressor operates.

Evaporator Coil - The evaporator coil is located in the cooling compartment. As low pressure liquid passes through the evaporator coil, it absorbs and removes heat from the compartment as it changes to vapor. The condenser and evaporator coil have aluminum fins attached to effectively increase their heat exchange surfaces.

Evaporator Fan and Motor - The evaporator fan and motor are a forced-air device circulating air throughout the cooling compartment and over the heat exchange surface of the evaporator coil.

Drier - The drier is located in the refrigerant line between the capillary tube and condenser. It traps and removes

moisture from the refrigeration system while allowing oil and refrigerant to pass through the system.

Refrigeration Control - The refrigeration temperature, lighting, and vend mechanism are all controlled by a microprocessor-based electronic circuit board located behind the service door. (Refer to *SECTION 3: Vender Programming* for details on setting the refrigeration set point.)

REFRIGERATION CYCLE

1. The rising temperature in the cooling compartment is reported to the control board through the temperature sensor.
2. The control board registers the current temperature inside the vender's cabinet. When it rises equal to or above the pre-programmed cut-in temperature, the control board will complete the circuit to the refrigeration relay to energize its coil.
3. The refrigeration relay coil closes the contact between the common and normally-open positions, allowing 115 volts to travel to the main wiring harness to start the compressor.
4. The compressor circulates refrigerant throughout the system by pulling low-pressure refrigerant vapor from the evaporator coil, compressing it, and forcing it into the condenser. The condenser, aided by the condenser fan motor, removes heat from the refrigerant as it flows through the condenser and releases it to the outside environment. The dropping of the refrigerant temperature changes the vapor to liquid.

5. The evaporator coil allows the liquid refrigerant to absorb heat from the cooling compartment as it evaporates in the coil.

6. The falling temperature in the cooling compartment is caused by the continual circulation of refrigerant through the system, removing heat from the cooling compartment and transporting it to the outside environment. When the temperature drops, the temperature sensor reports this to the vender's control board.

7. When the temperature drops below the preset cut-out temperature, the control board will disable the refrigeration relay, thus killing power to the refrigeration unit.

REFRIGERATION SYSTEM

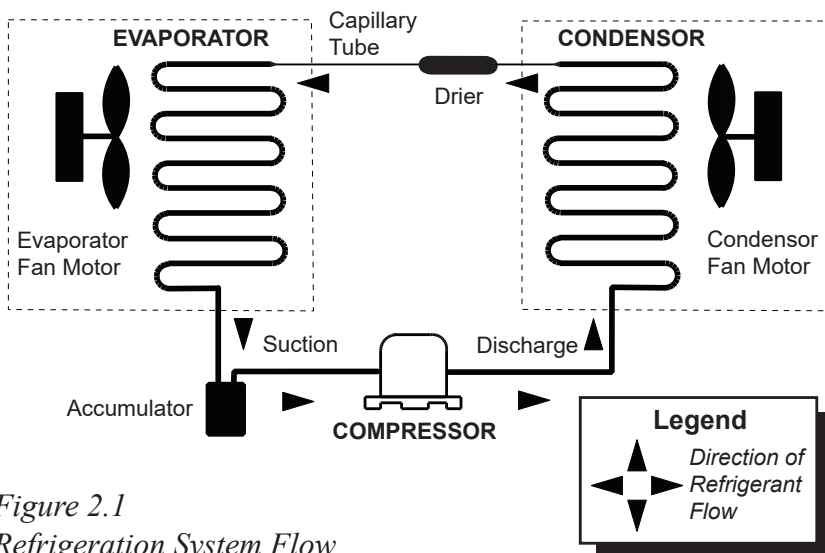

Figure 2.1
Refrigeration System Flow

SECTION 2: Vender Component Explanation

TESTING THE REFRIGERATION SYSTEM

1. The sealed refrigeration unit can be tested by unplugging it from the top of the main wiring harness and plugging it directly into a power source. If the unit still does not operate, a problem exists within the sealed unit.
2. If the sealed unit runs when plugged into an external power source, the problem more than likely lies between the control board, the refrigeration relay, and the main wiring harness.

Credit Peripherals

There are three possible credit peripherals for the RVV 700: the coin changer, bill acceptor, and debit card reader. The coin changer determines the validity and value of each coin that is inserted into the vender and sends the coin information to the vender controller. The coin changer also continuously informs the vender controller if coins are available in the change tubes to be used for change payout. The bill acceptor determines the validity and value of each bill that is inserted and sends that information to the vender controller. The debit card reader allows customers to purchase a product using a debit or credit card. For detailed information on any of the credit peripherals, refer to the separate operation and service manual provided by the peripheral's manufacturer.

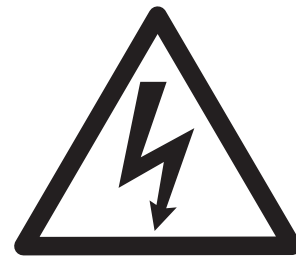

WARNING

ELECTROCUTION HAZARD

When plugging the refrigeration unit directly into a wall outlet or other external electrical source, the refrigeration unit **MUST** remain in the vender for proper grounding. If the unit is removed from the vender, an electrocution hazard exists.

SECTION 2: Vender Component Explanation

SECTION 3: Vender Programming

Vender Programming

PRECAUTIONS TO TAKE WHEN WORKING WITH CONTROL BOARDS

As with any printed circuit board, our electronics are very sensitive to Electrostatic Discharge (ESD). Simply walking across a tile or carpeted floor can generate a range of 30,000 to 50,000 volts of electricity. One ESD can be enough to seriously damage your control board or at least weaken it enough that erratic problems could occur in the future. Even a discharge surge under 100 to 200 volts is enough to create problems within the circuitry of the electronics. It is advised when storing the electronics that they be kept in anti-static bags, even if the electronics are thought to be defective. If a control board is thought to be defective and is really not, it soon will be after being charged with ESD. **The ideal prevention against ESD is to use anti-static conductive wrist straps which ground you to the machine before touching the electronic boards.** If it is not possible to use these, at least ground yourself before handling the electronic boards by touching the metal framework of the vender. Whatever method you use, always handle the electronic boards by the edges. Be careful not to touch the components on the control board.

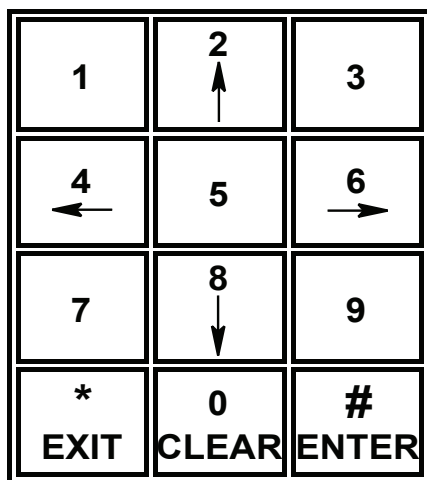

Figure 3.1
Touch Pad

TOUCH PAD PROGRAMMING

It is very important that the RVV 700 is programmed properly. All programming of the vender options is done in the Service Mode. To enter the Service Mode, open the vender door, and press and release the blue mode button located on the control board.

The vender's touch pad consists of 12 buttons. Five of these buttons (see Figure 3.1, below left) are used to program the vender and navigate through the service routines as follows:

Button	Meaning	Usage
2	FORWARD	Increase, next, up
8	BACKWARD	Decrease, previous, down
0	CLEAR	Clear errors
*	EXIT	Escape, cancel, exit
#	ENTER	OK, accept, save

The controller will automatically return to the Sales Mode if:

- No response from the touch pad is received for approximately five minutes;
- The service mode button is pressed a second time;
- The door is actually closed; or
- The three-way door switch is pulled out.

If credit exists, the credit amount will be displayed after returning to the Sales Mode.

MENU SYSTEM

When programming, you must first use the programming buttons listed above to maneuver through menus and sub-menus before you will be allowed to accomplish your task. Each menu consists of various items, or modes, such as "Set Prices" Mode or the "Set Date / Time" Mode. There are two menus:

1. INTERNAL (Service) MENU - This menu is available only with the vender's door open. It is accessed upon pressing the control board's mode button.
2. EXTERNAL MENU - This menu is available by entering the proper external password with the vender's door closed. (See "Preview Password" in the following section.) From this menu, cash / sales counts and vender errors can be read (but not cleared).

To exit out of the menu at any time, press <exit> from any main mode prompt or close the vender's door.

Note: Programming flowchart located in rear of manual.

SECTION 3: Vender Programming

Internal (Service) Menu

Errors

(NOTE: If no errors have been recorded since the last reset, the menu item displayed here will be “No Errors”.) If <enter> is pressed at the “Errors” prompt, the controller will enter the error display mode. If no errors have occurred since the last error reset, the display will show “No Errors”. If an error has been detected since the last error reset, the display will show the first summary error code that has occurred, such as “Vend Mechanism”, which would indicate a vend error. Pressing <up> or <down> will allow you to cycle through all of the summary error codes that are present. Pressing <enter> at the displayed summary error code will allow you to view the detailed error codes beneath the summary error heading (see below). Pressing <up> or <down> at this point will allow you to cycle through all the detailed error codes that are present beneath the summary error code. If the <exit> button is pressed anytime during this operation, the controller will return to the “Errors” prompt. Press the <down> button to proceed to the next prompt, “System Info”.

If the <clear> button is pressed during the display of any detailed error code, that error will be cleared. If other errors exist that fall under the currently accessed detail type, the next error would be displayed. If no other errors of the current type exist, the next error summary code will be displayed, or “No Errors” will be displayed if no other errors exist.

The error summary codes and their corresponding detailed error codes are as follows:

- **Control System**

By pressing <enter> at the “Control System” prompt, the controller will display:

1. “Door Switch,” indicating the door switch has been open for more than an hour;
2. “RAM Checksum,” indicating the machine setup information has been corrupted;
3. “DC Under Voltage,” indicating that the average rectified voltage was under 20VDC for more than 30 seconds;
4. “DC Over Voltage,” indicating that the average rectified voltage was over 45VDC for more than 30 seconds;
5. “System Scale Factor,” indicating one of the credit peripherals has introduced an incompatible scaling factor;

6. “Inlet Sense,” indicating the machine’s coin inlet sensor has been blocked for more than a minute (note: this is an optional component not installed on all venders); or
7. “Inlet Blocked,” indicating two coins were sensed at the inlet sensor but didn’t make it to the changer within 10 seconds.

After taking corrective action to manually fix the “Control System” errors, the errors may be cleared electronically via a hand-held device or through the service mode using the <clear> button.

- **Selection Switch**

By pressing <enter> at the “Selection Switch” prompt, the controller will display “Selection Switch XX,” where “XX” indicates the first selection switch that has been determined to be closed for more than 15 seconds. If there is a selection key error, navigation of the service menu will not be possible. This error can only be cleared by manually correcting or replacing the keypad.

- **Changer**

By pressing <enter> at the “Changer” prompt, the controller will display either:

1. “Changer Comm,” indicating no changer communications for more than 2 seconds;
2. “Tube Sense,” indicating a tube sensor error;
3. “Changer Inlet,” indicating no coins sensed by acceptor for over 96 hours;
4. “Tube Jam XX,” indicating a tube jam error for coin type XX;
5. “Changer ROM,” indicating a changer ROM checksum error;
6. “Excessive Escrow” indicating more than 255 escrow attempts since the last coin was accepted;
7. “Coin Jam,” indicating a coin jam;
8. “Low Acceptance,” indicating a low acceptance rate (more than 20% of the last 255 coins were slugs);
9. “Disconnected Acceptor,” indicating an unplugged acceptor; or
10. “Misrouted Coin,” indicating a coin had been improperly routed.

The “Changer Comm” error will be cleared when proper communications are re-established. After taking corrective action to manually fix the other “Changer” problems, the errors may be cleared electronically via a hand-held device or through the service mode using the <clear> button.

SECTION 3: Vender Programming

- **Bill Validator**

By pressing <enter> at the “Bill Validator” prompt, the controller will display either:

1. “Bill Val Comm,” indicating no bill validator communications for more than 5 seconds;
2. “Bill Stacker Full,” indicating a full bill stacker;
3. “Bill Motor,” indicating a defective motor;
4. “Bill Jam,” indicating a bill jam error;
5. “Bill Val ROM,” indicating a bill acceptor ROM check sum error;
6. “Open Cash Box,” indicating an open cash box; or
7. “Bill Sensor,” indicating a bill sensor error.

The “Bill Val Comm” error will be cleared when proper communications are re-established. After taking corrective action to manually fix the other “Bill Validator” problems, the errors may be cleared electronically via a hand-held device or through the service mode using the <clear> button.

- **Card Reader**

By pressing <enter> at the “Card Reader” prompt, the controller will display either:

1. “Card Reader Comm,” indicating no card reader communications for more than 5 seconds; or
2. “Card Reader Error XY,” indicating that a particular type of card reader malfunction occurred where “XY” indicates the error type.

The “Card Reader Comm” error will be cleared when proper communications are re-established. The “Card Reader Error XY” errors may be reset via the hand-held device or through the service mode using the <clear> button.

- **Vend Mechanism**

By pressing <enter> at the “Vend Mechanism” prompt, the controller will display either:

1. “Delivery System,” indicating that there is a generic vend mechanism error;
2. “Cup Sensor,” indicating that the cup sensor has malfunctioned;
3. “Home Sensor,” indicating that the home sensor has malfunctioned;
4. “Critical Mech,” indicating a critical vend mechanism error has occurred;
5. “Delivery Port Sense,” indicating that the VMC is reporting a port sense error; or
6. “Delivery Port Door,” indicating that the VMC is

reporting a port door error.

After taking corrective action to manually fix the “Vend Mechanism” errors, the errors may be cleared electronically via a hand-held device or through the service mode using the <clear> button. (NOTE: Error seen when reviewing menu is ‘Cell19 Failed to Vend’.)

- **Space to Sales**

By pressing <enter> at the “Space to Sales” prompt, the controller will display “Unassigned Cell XX,” indicating that cell XX is unassigned. These errors are cleared when new space to sales programming resolves the errors or via the service mode using the <clear> button. (Note: When an unassigned cell is selected in the sales mode, the display will show “No Sales Available.”)

- **Refrigeration**

By pressing <enter> at the “Refrigeration” prompt, the controller will display either:

1. “Temperature Sensor,” indicating an unplugged temperature sensor error;
2. “Temperature Too Cold,” indicating temperatures 3° F (1.5° C) below the compressor cut-out setting;
3. “Temperature Too Hot,” indicating temperatures 3° F (1.5° C) above the compressor cut-in setting;
4. “Compressor,” indicating that the compressor is not cooling at 1° F (0.5° C) per hour or better while on;
5. “Heater,” indicating that the heating system is not heating at 1° F (0.5° C) per hour or better while on;
6. “Not Cooling,” indicating an inability to reach the set point temperature; or
7. “Health Safety Failed,” indicating that the health safety limit temperature has been violated.

The “Temperature Sensor” error will be cleared if the sensor is detected. The “Temperature Too Cold” error will be cleared when the temperature rises above the cut-out limit. The “Temperature Too Hot” error will be cleared when the temperature falls below the cut-in limit. The “Compressor” error will be cleared when the system cools at 1° F (0.5° C) per hour or better. The “Heater” error will be cleared when the system heats at 1° F (0.5° C) per hour or better. The “Not Cooling” error must be manually cleared electronically via a hand-held device or through the service mode using the <clear> button. All other “Refrigeration” errors can also be cleared via the hand-held device or through service mode using the <clear> button.

SECTION 3: Vender Programming

System Info

If <enter> is pressed at the “System Info” prompt, the current system information will be displayed, as follows:

Time (displays current day, date, and time)
Machine Model No.
Machine Serial No.
VMC Model No.
VMC Serial No.
Boot Loader
Version
Cup
Port

If the <enter> or <exit> buttons are pressed anytime during this operation, the controller will return to the “System Info” prompt. Press the <down> button to proceed to the next prompt, “Tube Fill”.

Tube Fill

If <enter> is pressed at the “Tube Fill” prompt, the controller will enter the tube fill mode, and “Tube Fill” will be highlighted. This mode allows any coin that is routed to a tube to be deposited, providing total accountability. The tube inventory level for the deposited coin will be displayed after the coin is accepted. If a tube full status is detected, that coin will no longer be accepted. During this entire operation, MIS tube counts will be updated accordingly. If <exit> is pressed at any time, the controller will return to the unhighlighted “Tube Fill” prompt. Press <down> to proceed to the next prompt, “Coin Payout”.

Coin Payout

If <enter> is pressed at the “Coin Payout” prompt, the controller will enter the coin payout routine. “Coin Payout” will be highlighted, along with the lowest-available coin tube value. Pressing <enter> when a particular coin value is displayed will pay out the displayed coin type at half-second intervals until the button is released, and the display will show the coin value followed by the quantity of times paid out. Press <up> or <down> will scroll to the next available coin tube value. All coins dispensed in this mode are counted in the MIS tube counts and the manual dispense mode counters. If <exit> is pressed at any time, the controller will return to the unhighlighted “Coin Payout” prompt. Press <down> to proceed to the next prompt, “Test Modes”.

Test Modes

If <enter> is pressed at the “Test Modes” prompt, the controller will enter the test modes. Using <up> or <down> will allow you to cycle through the available tests. If <exit> is pressed at any time, the controller will return to the “Test Modes” prompt. Use <down> to proceed to the next prompt, “Enter Password” (if the password has not already been entered) or “Cash Counters” (if the password has been entered).

Test Vend

If <enter> is pressed at the “Test Vend” prompt, the controller will enter the test vend routine. This routine will allow the operator to test the functionality of the vending mechanism and of the individual cells. “Test Vend”, followed by “All”, will be highlighted. To test a selection, type in the desired selection number using the vender’s keypad. Pressing <enter> or “0” at “All” will cause a sequential vend from cell 10 all the way to the last cell. Press <exit> to return to the unhighlighted “Test Vend” prompt. Press <down> to proceed to the next prompt, “Test Selection Switches”.

Test Selection Switches

If <enter> is pressed at the “Test Selection Switches” prompt, the controller will enter the selection switch test mode. This mode tests the functionality of the keypad. The display will be highlighted, showing “Test Selection Switches #”, the switch number of the <enter> key. With each subsequent press of a key, the display will show that particular key number on the display. Keys labeled 1-9 are displayed as “1” to “9”; the 0 and # keys are displayed as “11” and “12,” respectively. To exit the selection switch test mode, press the <exit> key. (Doing so will also test the functionality of the * key.) This will return the controller to the unhighlighted “Test Selection Switches” prompt. Press <down> to proceed to the next prompt, “Test Display”.

Test Display

Pressing <enter> at the “Test Display” prompt will cause the controller to enter the display test routine. This routine allows you to test the display. Upon entry into this routine, the display will light up in successive bands of red, green, and blue. The test will continue indefinitely until <exit> is pressed, at which time the controller will return to the “Test Display” prompt. Press <down> to proceed to the next prompt, “Test Relays”.

SECTION 3: Vender Programming

Test Relays

Pressing <enter> at the “Test Relays” prompt will cause the controller to enter the relay test routine. This routine allows you to test the various relays within the vender. Upon entry into this routine, the display will show a series of available relays to test, beginning with “Heater”. The box to the right of the relay name will contain a check mark when turned on; when not turned on, the box will be empty. Pressing <up> or <down> will cycle through the available relays that can be tested. Pressing <enter> at the displayed relay will toggle its state between on (check mark) or off (empty box). *Note: To prevent equipment malfunctions, relay states should not be toggled more than once every 10 seconds.* If <exit> is pressed at any time, the display will return to the “Test Relays” prompt. Press <down> to proceed to the next prompt, “VendMech Diagnostics”.

The relays available for testing are:

Heater - controls the optional heater relay
Compressor – controls the compressor (refrigeration unit) relay
Evaporator – controls the evaporator fan motor relay (<enter>, highlight, says “Off” — push <2> to cycle to “Low”, then <2> to cycle again to “High”)

VendMech Diagnostics

Pressing <enter> at the “VendMech Diagnostics” prompt will cause the controller to enter the diagnostic test routine. The display will show “Run Cup”. Use <up> or <down> to cycle through the available diagnostic tests. *Note: If no activity is noticed after 90 seconds, the controller will exit the service menu.*

Run Cup (Pass / Fail)

Pressing <enter> at “Run Cup” will cause the vender to actuate the plunger in the cup, during which the plunger will stick out and turn. This allows service personnel to observe if there are any problems with the cup plunger that would inhibit vending. “Running” will be displayed while this test is carried out. When the vender has completed the test, “Pass” or “Fail” will be displayed as appropriate. Press <down> to proceed to the next prompt, “Perimeter Test”.

Perimeter Test (x5)

Pressing <enter> at “Perimeter Test” will cause the vender to move the cup around the perimeter of the vending area five times. This allows service personnel to observe if there are any obstructions around the perimeter of the vender that would inhibit vending. “Running” will be displayed while this test is carried out. When the vender has completed the test, “Pass” or “Fail” will be displayed as appropriate. Pressing <exit> will terminate the test. Press <down> to proceed to the next prompt, “Figure-8 Test”.

Figure-8 Test (x5)

Pressing <enter> at “Figure-8 Test” will cause the vender to move the cup in a figure-eight motion to each corner of the vender five times. This allows service personnel to observe if there are any obstructions that would prevent the free movement of the cup. “Running” will be displayed while this test is carried out. When the vender has completed the test, “Pass” or “Fail” will be displayed as appropriate. Pressing <exit> will terminate the test. Press <down> to proceed to the next prompt, “Delivery Test”.

Delivery Test (Pass / Fail)

Pressing <enter> at “Delivery Test” will cause the cup to run to and open the delivery door three times. This allows service personnel to observe if there are any malfunctions in the delivery door or the cup’s ability to access the delivery door. “Running” will be displayed while this test is carried out. When the vender has completed the test, “Pass” or “Fail” will be displayed as appropriate. Pressing <exit> will terminate the test. Press <down> to proceed to the next prompt, “Production Test”.

Production Test (Pass / Fail)

Pressing <enter> at “Production Test” will cause the cup to perform a series of events: the cup’s plunger will stick out and turn; the home magnet will be located; the delivery test will be performed three times; each cell will be located; the perimeter test will be performed five times; the Figure-8 test will be performed five times; a product will be vended from cell X0, X5, and X9 on each shelf; and the cup will return to its home position. Production test is a combination of other available tests. “Running” will be displayed while this test is carried out. When the vender has completed the test, “Pass” or “Fail” will be displayed as appropriate. Pressing <exit> will terminate the test. Press <down> to proceed to the next prompt, “Port”.

Port

Pressing <enter> at the “Port” prompt will cause the controller to enter the port functions test routines. The display will show “Lock Outer Door”. Use <up> or <down> to cycle through the available tests.

SECTION 3: Vender Programming

Lock Outer Door (check box)

Upon pressing <enter> at “Lock Outer Door”, the check mark will be removed from the box and the outer door should unlock. Pressing <enter> again should cause the door to lock securely. From “Lock Outer Door”, press <down> to proceed to the next prompt, “Close Outer Door”.

Close Outer Door (Pass / Fail)

Pressing <enter> at the “Close Outer Door” prompt will cause the controller to enter the outer door lock test routine. Upon entry into this routine, the outer door should lock securely (if it was already open). From “Close Outer Door”, press <down> to proceed to the next prompt, “Open Outer Door”.

Open Outer Door (Pass / Fail)

Pressing <enter> at the “Open Outer Door” prompt will cause the controller to enter the inner door unlock test routine. Upon entry into this routine, the inner door should open (if it was closed). From “Open Outer Door”, press <down> to proceed to the next prompt, “Lock Inner Door”.

Lock Inner Door (check box)

Pressing <enter> at the “Lock Inner Door” prompt will cause the controller to enter the inner door lock test routine. Upon entry into this routine, the inner door should lock securely. If <enter> is pressed a second time, the inner door should unlock. From “Lock Inner Door”, press <down> to proceed to “Light”.

Light (check box)

Upon pressing <enter> at the “Light” prompt, a check mark should appear in the box on the display and the port light should illuminate. Pressing <enter> again will cause the light to shut off. From “Light”, press <exit> to return to the “Port” prompt. Press <down> to proceed to “Motors”.

Motors

Upon pressing <enter> at “Motors”, the display will show the current X and Y coordinates of the cup. Press the following keys to perform the motor tests:

- Press <up> to test the Y-axis motor by moving the cup upward. The Y coordinate on the display should decrease by approximately 50 steps. Pressing <down> should move the cup downward, with the Y coordinate increasing by approximately 50 steps.
- Press <right> to test the X-axis motor by moving the cup to the right. The X coordinate on the display should decrease by approximately 50 steps. Pressing <left> should move the cup leftward, with the X coordinate increasing by approximately 50 steps.

Pressing <exit> will return the display to the “Motors” prompt. Press <exit> again to return to “VendMech Diagnostics”, then press <down> to proceed to “Sensors”.

Sensors ***(NOTE: This mode is still in development.)***

Calibration

The vend mechanism calibration routines allow the controller to automatically calibrate vending and delivery positions. Upon pressing <enter>, “Calibration” will be highlighted, at which point a password must be entered. Key in the calibration password (3-4-5-6), followed by <enter>. After correct entry, the display will show the first routine, “Package Size Mapping”.

Package Size Mapping

This routine allows the operator to increase or decrease the number of plunger revolutions required to drive a product into the delivery cup. If <enter> is pressed, three package size options can be set: Small, Standard, or Large. The default package size settings, by number of revolutions, are:

- Small: 300 revolutions
- Standard: 520 revolutions
- Large: 690 revolutions

Press <up> or <down> to scroll through the available sizes. To change a setting, press <enter> to highlight the item, then type in the desired number of revolutions using the keypad. Press <enter> to save the setting. Once each package size has been set, press <exit> to return to the “Package Size Mapping” prompt. Press <up> to proceed to the next prompt, “Calibrate Selection”.

SECTION 3: Vender Programming

Calibrate Selection

This routine allows automatic calibration of vending positions by selection. Upon pressing <enter>, “Calibrate Selection” will be highlighted, along with “ALL”. Press <enter> to calibrate all selections, or key in a particular selection number to calibrate individually. Once calibration has been performed, press <exit> to return to the “Calibrate Selection” prompt. Press <up> to proceed to the next prompt, “Calibrate Port”.

Calibrate Port

This routine allows calibration of the delivery position. Upon pressing <enter>, the product cup will perform a delivery routine. Once this routine is complete, the display will show “Pass”, if the delivery routine has been performed successfully, or “Fail”, if the product cup was unable to complete the delivery routine properly. If calibration of the delivery position fails, an error code should be recorded. (*See the error display mode, “Errors”, at the beginning of the Internal Service Menu for more information.*) Once this routine is complete, press <up> to proceed to the next prompt, “Lighting Activity Time”.

Lighting Activity Time

This menu item allows the operator to determine the length of time the vender’s illumination system will remain at full brightness after activity, such as product vending. The default setting is 300 seconds. If <enter> is pressed, the menu item will be highlighted. To change the setting, press <enter> to highlight the item, then type in the desired number of seconds that the lights will remain at full brightness. Press <enter> to save the setting and return the display to the unhighlighted state. Press <exit> once to return to the “Calibration” prompt or two times to return to the “Test Modes” prompt.

Enter Password

To enter the password, touch the following keys in sequence: <enter>, 4-2-3-1, then <enter>. The VMC will allow up to 10 seconds to enter the password. If the password is not correctly entered in 10 seconds, the display will return to “Enter Password”. If the correct password is entered, the display will show “Cash Counters”.

Cash Counters

If <enter> is pressed at the “Cash Counters” prompt, the controller will enter the cash counters display mode. The display will show “Total” at the top line and each selection below that (as “Selection NN”, where “NN” represents the appropriate selection number). To the right, a currency amount will be shown, as follows:

- “Total” is the currency amount taken in for all paid vends over the life of the vender’s control board.
- “Selection NN” is the currency amount taken in for all paid vends for the given selection number since the last reset *or* over the life of the vender’s control board. (*Refer to C5 in Configurations.*)

Using <up> or <down> will cycle through each selection. If <exit> is pressed anytime during this operation, the controller will return to the “Cash Counters” prompt. Press <up> to proceed to the next prompt, “Sales Counters.”

Sales Counters

If <enter> is pressed at the “Sales Counters” prompt, the controller will enter the sales counters display mode. The display will show “Total” at the top line and each selection below that (as “Selection NN”, where “NN” represents the appropriate selection number). To the right, an amount will be shown, as follows:

- “Total” is the quantity of all products vended over the life of the vender’s control board.
- “Selection NN” is the quantity of product vended by the given selection number since the last reset *or* over the life of the vender’s control board. (*Refer to C5 in Configurations.*)

Using <up> or <down> will cycle through each selection. If <exit> is pressed anytime during this operation, the controller will return to the “Sales Counters” prompt. Press <up> to proceed to the next prompt, “Card Counters.”

SECTION 3: Vender Programming

Card Counters

If <enter> is pressed at the “Card Counters” prompt, the controller will enter the card counter display mode by displaying three lines: “Total” on the first line, “Vends XXXX” on the second line, and “Value YYYY.YY” on the third line. The X’s represent the number of all card vends over machine life, and the Y’s represent the value of all card sales over machine life. Using <up> or <down> will cycle through each selection by displaying “Selection N” on the first line, “Vends XXXX” on the second line, and “Value YYYY.YY” on the third line. “N” will represent the selection number. The individual counts are resettable. If <exit> is pressed anytime during this operation, the controller will return to the “Card Counters” prompt. Press <down> to continue to the next prompt, “Token Counters”.

Token Counters

If <enter> is pressed at the “Token Counters” prompt, the controller will enter the token counter display mode by displaying three lines: “Total” on the first line, “Vends XXXX” on the second line, and “Value YYYY.YY” on the third line. “Token Counters” functions exactly as “Card Counters” does, except that it counts token vends instead of card vends. (See above.) If <exit> is pressed anytime during this operation, the controller will return to the “Token Counters” prompt. Press <up> to proceed to the next prompt, “Discount Counters”.

Discount Counters

If <enter> is pressed at the “Discount Counters” prompt, the controller will enter the discount counter display mode by displaying three lines: “Total” on the first line, “Vends XXXX” on the second line, and “Value YYYY.YY” on the third line. “Discount Counters” functions exactly as “Card Counters” does, except that it counts discounted vends instead of card vends. (See above.) If <exit> is pressed anytime during this operation, the controller will return to the “Discount Counters” prompt. Press <up> to proceed to the next prompt, “Free Vend Accounting”.

Free Vend Accounting

If <enter> is pressed at the “Free Vend Accounting” prompt, the controller will enter the token counter display mode by displaying three lines: “Total” on the first line, “Vends XXXX” on the second line, and “Value YYYY.YY” on the third line. “Free Vend Accounting” functions exactly as “Card Counters” does, except that it counts free vends instead of card vends. (See above.) If <exit> is pressed anytime during this operation, the controller will return to the “Free Vend Accounting” prompt. Press <up> to proceed to the next prompt, “Set Prices”.

Set Prices

If <enter> is pressed at the “Set Prices” prompt, the controller will enter the price setting mode. If multiple prices are enabled in “Configurations”, the display will show “All”, “Shelf”, and “Selection”. Press <up> or <down> to cycle through these options. If multi-price is disabled, only “All” will be shown after pressing <enter> at the “Set Prices” prompt.

If <enter> is pressed at “All”, this item and the current price for all selections will be highlighted. To change this universal price, type in the desired price using the keypad. Once the desired price is shown, press <enter> to save it and return the display to the unhighlighted state. If multi-price is enabled, use <up> to proceed to the next menu item, “Shelf”. If multi-price is disabled, use <exit> to return to the “Set Prices” prompt, then press <up> to proceed to the next prompt, “Space to Sales”.

If <enter> is pressed at “Shelf”, each shelf number will be displayed, followed by the current universal price for the shelf. Press <up> or <down> to cycle through each individual shelf number. If <enter> is pressed at a particular shelf number, that shelf and its current price setting will be highlighted. To change this price, type in the desired price using the keypad. Once the desired price is shown, press <enter> to save it and return the display to the unhighlighted state. Once all shelf prices have been set, press <exit> to return to the “Shelf” prompt. Press <up> to proceed to the next menu item, “Selection”.

If <enter> is pressed at “Selection”, each selection number will be displayed, followed by its current set price. Press <up> or <down> to cycle through each individual selection number. If <enter> is pressed at a particular selection number, that selection and its current price setting will be highlighted. To change this price, type in the desired price using the keypad. Once the desired price is shown, press <enter> to save it and return the display to the unhighlighted state. Press <exit> to return to the “Selection” prompt, then press <exit> a second time to return to the “Set Prices” prompt. Press <up> to proceed to the next available prompt, “Space to Sales”.

SECTION 3: Vender Programming

Space to Sales

If <enter> is pressed at the “Space to Sales” prompt, the controller will enter the space-to-sales programming mode. Use <up> or <down> to scroll between the various space-to-sales options. The following options are available within this menu:

One-to-One
By Half-Rows
By Rows
Custom
Vend Evenly

One-to-One, By Half-Rows, and By Rows

Once the desired option is reached, press <enter> to save that option, then <up> or <down> to scroll through the remaining menu items or <exit> to return to the “Space to Sales” prompt.

Custom

If <enter> is pressed at the “Custom” prompt, you will have the opportunity to program a custom space to sales configuration. Upon entry into this routine, the display will show “Clear Selections” and “Go to Selection”. Pressing <exit> at this point will return the display to the “Custom” prompt with no changes being made.

To clear the current space-to-sales assignments, press <enter> at the “Clear Selections” prompt, and the third row of text on the display will show “Unassigned Cells All”. From “Clear Selections”, press <down> to scroll to “Go to Selection”.

At the “Go to Selection” prompt, press <enter>. “Go to Selection” will be highlighted on the display. To assign cells to a selection number, key in the number of the selection using the keypad, then press <enter>. A list of all cells within the vender will be shown, accompanied by the following information:

- If the cell is currently assigned to the entered selection number (shown at the top of the display), a checked box will follow the cell number. To unassign this cell, press <enter>, and the box will be empty.
- If the cell is currently assigned to another selection, but not the entered selection number, “Selection NN” will follow the cell number (where “NN” is the number of the selection). To assign this cell to the current selection, press <enter>.
- If the cell is currently unassigned to any selection, an unmarked box will appear.

Pressing <up> or <down> will scroll the display through each individual cell number. Once all desired cells have been assigned to the entered selection, press <exit>. The display will return to the highlighted “Go to Selection” prompt. Type in another selection number to enter into it.

Once all selections have been assigned as desired, press <exit> from the “Go to Selection” prompt. The display will show “Save?”. Press <enter> to save the new settings and return the display to the “Custom” prompt.

Notes: Selection pricing must be aligned with the space-to-sales assignments.

Vend Evenly

If <enter> is pressed at “Vend Evenly”, the check box will be toggled between checked (all cells tied together in space-to-sales will alternate vending for even distribution) or unchecked (each cell will be vended until empty before product is dispensed from the next tied cell).

SECTION 3: Vender Programming

Set Package Sizes

If <enter> is pressed at the “Set Package Sizes” prompt, the controller will enter the package setting mode. This mode is used to adjust selections to vend certain small packages reliably. Using <up> or <down> will allow you to cycle through the various options for setting package size (“All”, “Shelf”, or “Cell”). For each option, three package size selections are available: Small, Standard, or Large.

All

If <enter> is pressed at “All”, this line will be highlighted, and the package size for all cells can be set at once. Press <up> or <down> to change the universal size. Once the desired package size is shown, press <enter> to save it and return the display to the unhighlighted state. Use <up> to proceed to the next option, “Shelf”, or press <exit> to return to the “Set Package Sizes” prompt.

Shelf

If <enter> is pressed at “Shelf”, each shelf number will be displayed, followed by the current universal package size for the shelf. Press <up> or <down> to cycle through each individual shelf number. If <enter> is pressed at a particular shelf number, that shelf and its current package size setting will be highlighted. Use <up> or <down> to change this size. Once the desired package size is shown, press <enter> to save it and return the display to the unhighlighted state. Once all shelves’ package sizes have been set, press <exit> to return to the “Shelf” prompt. Press <up> to proceed to the next option, “Cell”.

If <enter> is pressed at “Cell”, each cell number will be displayed, followed by its current package size setting. Press <up> or <down> to cycle through each individual cell number. If <enter> is pressed at a particular cell number, that cell and its current package size setting will be highlighted. Press <up> or <down> to change this setting. Once the desired package size is shown, press <enter> to save it and return the display to the unhighlighted state. Press <exit> to return to the “Cell” prompt, then press <exit> a second time to return to the “Set Package Sizes” prompt. Press <up> to proceed to the next available prompt, “Configurations”.

Configurations

If <enter> is pressed at the “Configurations” prompt, the controller will enter the machine configuration mode by displaying “CN Configuration Name”, followed by a box (checked if enabled, empty if disabled). Using <up> or <down> will allow you to cycle through all available configuration options. If <exit> is pressed anytime during this operation the controller will return to the “Configurations” prompt. From the “Configurations” prompt, use <up> to proceed to the next prompt, “Correct Change”.

If <enter> is pressed the status will toggle between enabled and disabled. When the desired status is displayed, pressing <enter> will save that status. Press <up> or <down> to scroll through the available configurations.

- C2 - Optional Features Enable

This option is used to enable the optional menu, which contains several more mode options than available in the standard service menu. If this configuration is unchecked, all optional menu items will be disabled.

Unchecked: optional menu items will not appear.

Checked: optional menu items will appear.

- C3 - POS Disable

This option is used to turn off the display of the point-of-sales message.

Unchecked: the point-of-sales greeting will appear as normal.

Checked: the point-of-sales greeting will not appear on the display.

- C4 - Summary MIS Data Display

This option is used to turn on the display of the total machine sales and total machine cash values in the open-door mode.

Unchecked: only recorded error codes are displayed when the door is open.

Checked: sales and cash totals will be displayed, as well as recorded error codes.

SECTION 3: Vender Programming

- C5 - Door Switch MIS Reset

This option is used to allow the door switch to reset all resettable MIS.

Unchecked: all resettable MIS registers are reset only when the “CF” command is received from a Hand-Held Computer (HHC).

Checked: all resettable MIS registers are reset when the door switch is sensed as open and at least one of the resettable MIS registers has been read (i.e., cash and sales counts).

- C7 - Save Credit

This option is used to determine how long credit should remain on the display and available to the customer. If the feature is turned off, a five-minute timer is restarted each time credit is added to the machine, or any valid consumer action occurs. After the timer expires the credit is erased. If the feature is turned on, credit is left available to the customer regardless of when it was deposited.

Unchecked: the five-minute timer is used.

Checked: credit is left on the display for use indefinitely.

- C8 - Force Vend

This option prevents the machine from becoming a change maker. When this mode is enabled, escrow of coins is allowed until any of the following three events occurs: 1. Any bill is inserted into the bill acceptor; 2. Any “cash box” coin is inserted into the changer; or 3. The maximum vend price is reached. Once any of these conditions are met, any accumulated credit must be used toward a vend attempt, and coins will not be dispensed for credit in response to an escrow request. If a sold-out selection, or if a valid selection that becomes sold-out, is made, this option will be overridden, and an escrow will be honored.

Unchecked: forced vend attempt is disabled.

Checked: forced vend attempt is enabled.

Note that forced vend attempt has no effect on the card reader. Once a card is inserted, it can always be returned to the customer via the escrow lever on the changer or return button on the card reader.

- C9 - Multi-Vend

This option will allow multiple purchases without re-entering coins. If enabled, instead of immediately returning the change after a vend, the credit will remain on the display to be used for another selection. An escrow request will be honored at any time. This option will take precedence over the forced-vend option after the first vend has been completed.

Unchecked: multi-vend is disabled.

Checked: multi-vend is enabled.

- C10 - Bill Escrow Inhibit

This option will inhibit escrowing of bills. If disabled, and the current bill value inserted takes the accumulated credit over the maximum price, the bill will be held in the escrow position. If the rule is enabled, bills will always go to the cash box.

Unchecked: bill escrow is allowed.

Checked: bill escrow is inhibited.

SECTION 3: Vender Programming

Correct Change

If <enter> is pressed at the “Correct Change” prompt, the display will show “Consumer Overpay”. Using <up> or <down> will cycle through all available correct change options, as listed below. Pressing <exit> at any point in this procedure will return to the “Correct Change” prompt without saving any changes. Use <up> to proceed to the next prompt, “Preview Password”.

- **Consumer Overpay**

This submode is used to determine whether a vend should be allowed when an overpayment situation may result. If unchecked, the customer will not be cheated. If checked, when a customer makes a selection when the change levels are low and the “Use Correct Change Only” message is:

- **OFF:** The message will continue to be displayed for up to one minute. If after 2 seconds but before one minute expires the customer re-selects this same selection, the vend will continue and as much change as possible will be returned.
- **ON:** The message will continue to be displayed for up to one minute. However, the vend will continue and as much change as possible will be returned.

In either case above, remaining change due back to the customer will remain on the display. The customer could add change to the remaining value on the display to make another vend.

Note: If “Consumer Overpay” is checked, both “Correct Change Value” and “Unconditional Acceptance Value” will apply; if unchecked, only “Correct Change Value” will apply.

- **Correct Change Value**

When <enter> is pressed at “Correct Change Value”, the current value will be highlighted. The changer must be able to pay back this value and all values below that (in increments of the changer’s lowest tube value) for the correct-change message to remain off. In other words, if “Correct Change Value” is set to 0.25, the changer must be able to pay back 0.25, 0.20, 0.15, 0.10, and 0.05 in any combination, or else the correct change message will be displayed. If this value is set to 0.00, the “Use Correct Change Only” message will never be displayed.

- **Unconditional Acceptance Value**

When <enter> is pressed at “Unconditional Acceptance Value”, the current value will be highlighted. The vender should not accept any amount of currency (bill or coin) larger than the value set in “Unconditional Acceptance Value” unless the changer can pay out the equivalent of that amount.

Preview Password

At “Preview Password”, the current four-digit password for the external menu will be shown on the right-hand side of the display. If <enter> is pressed, this menu item will be highlighted, and the first digit of the number will be flashing. Pressing <up> or <down> will adjust the currently flashing digit up or down. Pressing <enter> will save the currently flashing digit and cause the next digit of the password to begin flashing. All digits may be modified in this manner. Pressing <exit> at any point in the procedure will save the currently displayed password and return you to the “Preview Password” prompt. From the “Preview Password” prompt, use <up> to proceed to the next prompt, “Set Date / Time”.

Set Date / Time

If <enter> is pressed at the “Set Date / Time” prompt, the controller will enter the current time setting mode by displaying “Date”. Using <up> or <down> will allow you to cycle through all available time setting options. If <exit> is pressed anytime during this operation, the controller will return to the “Set Date / Time” prompt. Use <up> to proceed to the next prompt, “Refrigeration”.

Date

The current date of the year will be displayed at “Date” in YYYY-MM-DD format. If <enter> is pressed at the “Date” prompt, this date will be highlighted. Pressing <up> or <down> at this point will increase or decrease the year. If <enter> is pressed, the year will be saved, and the month will be highlighted. Pressing <up> or <down> at this point will increase or decrease the month. Press <enter> again to save the month and highlight the day. Press <up> or <down> to increase or decrease the day. Finally, press <enter> again to save the day and return to the unhighlighted state. Use <up> to proceed to the next prompt, “Time”.

Time (<enter>, highlight, key in time)

If <enter> is pressed at the “Time” prompt, the current time is displayed in a 24-hour format. The left two digits of the display show the current hour setting; the right two digits show the current minutes. The hour setting will be flashing. Pressing <up> or <down> at this point will increase or decrease the hour setting. If <enter> is pressed, the minute setting will flash. Pressing <up> or <down> at this point will increase or decrease the minutes setting. Pressing <enter> again will save the displayed hour and minutes setting and return you to the “Time” prompt. Pressing <exit> while in editing mode will return you to the unhighlighted “Time” prompt without saving changes. Use <up> to proceed to the next prompt, “Enable Daylight Saving Time”.

SECTION 3: Vender Programming

Enable Daylight Saving Time

If <enter> is pressed at the “Enable Daylight Saving Time” prompt, the box will toggle between checked (daylight saving time enabled) or unchecked (daylight saving time disabled). If <exit> is pressed, the controller will return to the “Enable Daylight Saving Time” prompt. Press <up> to proceed to the next prompt, “DST starts the NN Sunday of MMM”.

DST starts the NN DDD of MMM

This menu item can be used to modify the start date for daylight saving time in the controller’s internal clock. By default, this item is set to “DST starts the 2nd Sunday of March”. If <enter> is pressed, the ordinal day (NN) will be highlighted. Use <up> or <down> to change the ordinal day. Once the desired ordinal day is shown, press <right>, and the day of the week (DDD) will be highlighted. Use <up> or <down> to change the day of the week. At the desired day of the week, press <right>, and the month (MMM) will be shown. After reaching the desired month using <up> or <down>, press <enter> to save the setting and return to the “DST starts the NN DDD of MMM” prompt. Press <up> to proceed to the next prompt, “Start Hour”.

Start Hour

This menu item is used to set the start time for daylight saving time in the controller’s internal clock. By default, this item is set to 02:00. If <enter> is pressed, this menu item will be highlighted, showing a time of 00:00. Use the keypad to manually enter the hour at which daylight saving time will begin, in four-digit notation. (For example, to set daylight saving time to begin at 2:00 a.m., key in “0200”.) Once the desired time is shown, press <enter> to save it. Press <up> to proceed to the next prompt, “DST stops the NN DDD of MMM”.

DST stops the NN DDD of MMM

This menu item can be used to modify the end date for daylight saving time in the controller’s internal clock. By default, this item is set to “DST stops the 1st Sunday of November”. If <enter> is pressed, the ordinal day (NN) will be highlighted. Use <up> or <down> to change the ordinal day. Once the desired ordinal day is shown, press <right>, and the day of the week (DDD) will be highlighted. Use <up> or <down> to change the day of the week. At the desired day of the week, press <right>, and the month (MMM) will be shown. After reaching the desired month using <up> or <down>, press <enter> to save the setting and return to the “DST stops the NN DDD of MMM” prompt. Press <up> to proceed to the next prompt, “Stop Hour”.

Stop Hour

This menu item is used to set the stop time for daylight saving time in the controller’s internal clock. By default, this item is set to 02:00. If <enter> is pressed, this menu item will be highlighted, showing a time of 00:00. Use the keypad to manually enter the hour at which daylight saving time will end, in four-digit notation. (For example, to set daylight saving time to end at 2:00 a.m., key in “0200”.) Once the desired time is shown, press <enter> to save it. Press <exit> to return to “Set Date / Time”.

SECTION 3: Vender Programming

Refrigeration

Conserve Energy

If <enter> is pressed at the “Conserve Energy” prompt, the box will toggle between checked (energy conservation mode enabled) or unchecked (energy conservation mode disabled). If <exit> is pressed, the controller will return to the “Conserve Energy” prompt. Use <up> to proceed to the next prompt, “Start Days.”

Start Days

If <enter> is pressed at the “Start Days” prompt, the controller will enter the start refrigeration energy conservation control days setting routine. Pressing <exit> at this point will return you to the “Start Days” prompt without saving any changes. Use <up> to proceed to the next prompt, “Start Time.”

If <enter> is pressed at the “Start Days” prompt, the display will show Sunday, the first day of the week, followed by a box. Press <up> or <down> to scroll through each day of the week or “All Days”. If <enter> is pressed at the day of the week, the box will be checked (refrigeration energy conservation control timer enabled for that day) or unchecked (refrigeration energy conservation control timer disabled for that day). Pressing <enter> again will save the displayed setting and return you to the unhighlighted day name. Pressing <exit> will return the controller to the “Start Days” prompt. Press <up> to proceed to the next prompt, “Start Time”.

Start Time

If <enter> is pressed at the “Start Time” prompt, the controller will enter the start refrigeration energy conservation control time setting routine. This time will be displayed in a 24-hour format. The left two digits of the display show the current hour setting; the right two digits show the current minutes. The hour setting will be flashing. Pressing <up> or <down> at this point will increase or decrease the hour setting. If <enter> is pressed, the minute setting will flash. Pressing <up> or <down> at this point will increase or decrease the minutes setting. Pressing <enter> again will save the displayed hour and minutes setting and return you to the unhighlighted “Start Time” prompt. Use <up> to proceed to the next prompt, “Stop Days.”

Stop Days

If <enter> is pressed at the “Stop Days” prompt, the controller will enter the stop refrigeration energy conservation control days setting routine. Pressing <exit> at this point will return you to the “Stop Days” prompt without saving any changes. Use <up> to proceed to the next prompt, “Stop Time.”

If <enter> is pressed at the “Stop Days” prompt, the display will show Sunday, the first day of the week, followed by a box. Press <up> or <down> to scroll through each day of the week or “All Days”. If <enter> is pressed at the day of the week, the box will be checked (refrigeration energy conservation control timer enabled for that day) or unchecked (refrigeration energy conservation control timer disabled for that day). Pressing <enter> again will save the displayed setting and return you to the unhighlighted day name. Pressing <exit> will return the controller to the “Stop Days” prompt. Press <up> to proceed to the next prompt, “Stop Time”.

Stop Time

If <enter> is pressed at the “Stop Time” prompt, the controller will enter the start refrigeration energy conservation control time setting routine. This time will be displayed in a 24-hour format. The left two digits of the display show the current hour setting; the right two digits show the current minutes. The hour setting will be flashing. Pressing <up> or <down> at this point will increase or decrease the hour setting. If <enter> is pressed, the minute setting will flash. Pressing <up> or <down> at this point will increase or decrease the minutes setting. Pressing <enter> again will save the displayed hour and minutes setting and return you to the unhighlighted “Stop Time” prompt. Press <up> to proceed to the next prompt, “Use Celsius”.

Use Celsius

If <enter> is pressed at the “Use Celsius” prompt, the box will toggle between checked (enabled to display temperatures in degrees Celsius) or unchecked (to display temperatures in degrees Fahrenheit). Pressing <enter> at this point will save the desired temperature mode and return you to the unhighlighted “Use Celsius” prompt. Pressing <exit> will return you to the unhighlighted “Use Celsius” prompt without saving changes. Use <up> to proceed to the next prompt, “Set Point.”

Set Point

The set point default is 36° F (2.0° C). If <enter> is pressed at the “Set Point” prompt, the controller will display the current set point temperature setting “xx F” or “xx.x C,” depending on the “Use Celsius” setting. Using <up> or <down> will increase or decrease the number by 1° F (0.5° C). Pressing <enter> will save the set point and return you to the unhighlighted “Set Point” prompt. Pressing <exit> will return to the unhighlighted “Set Point” prompt without saving changes. From “Set Point,” press <up> to proceed to the next prompt, “Storage Temperature”.

SECTION 3: Vender Programming

Storage Temperature

The default storage temperature will be 45° F (7.0° C). If <enter> is pressed at the “Storage Temperature” prompt, the controller will display the current storage temperature setting “xx F” or “xx.x C,” depending on the “Use Celsius” setting. Using <up> or <down> will increase or decrease the number by 1° F (0.5° C), over the range of 32° F to 75° F (0° C to 24° C). Pressing <enter> will save the storage temperature and return you to the unhighlighted “Storage Temperature” prompt. Pressing <exit> will return you to the unhighlighted “Storage Temperature” prompt without saving changes. From “Storage Temperature,” press <up> to proceed to the next prompt, “Display.”

Display

If <enter> is pressed at the “Display” prompt, the box will toggle between checked (display the temperature in sales mode) or unchecked (do not display the temperature). Pressing <enter> will save the currently displayed setting and return you to the unhighlighted “Display” prompt. Pressing <exit> will return you to the unhighlighted “Display” prompt without saving changes. From “Display,” press <up> to proceed to the next prompt, “Defrost Duration”.

Defrost Duration

The default defrost duration is four minutes. This setting is used to determine how long the vender will remain in defrost mode, when activated. If <enter> is pressed at the “Defrost Duration” prompt, the controller will highlight the display showing the current defrost duration setting. Using <up> or <down> will increase or decrease the duration setting by one minute. Pressing <enter> will save the currently displayed setting and return the user to the unhighlighted “Defrost Duration” prompt. Pressing <exit> will return to the unhighlighted “Defrost Duration” prompt without saving changes. From “Defrost Duration,” press <exit> to return to the “Refrigeration” prompt.

Lighting Control

If <enter> is pressed at the “Lighting Control” prompt, the controller will enter the lighting control mode. Using <up> or <down>, you can cycle through the various lighting control settings. If <exit> is pressed, the controller will return to the “Lighting Control” prompt. From this prompt, press <up> to proceed to the next prompt, “Selection Block 1”.

Active Brightness (100)

Upon first entry into “Lighting Control,” the controller will display “Active Brightness”. This menu item is used to set the brightness of the vender’s LED illumination when the vender is in active mode. The default setting is 100 percent. If <enter> is pressed at “Active Brightness,” the prompt and the current setting (0 to 100 percent) will be highlighted. Press <up> or <down> to change the brightness of the LED illumination. Pressing <enter> will save the displayed setting and return you to the unhighlighted “Active Brightness” prompt. From the “Active Brightness” prompt, use <up> to proceed to the next prompt, “Inactive Brightness.”

Inactive Brightness (50)

This menu item is used to set the brightness of the vender’s LED illumination when the vender is in an inactive state. The default setting is 50 percent. If <enter> is pressed at “Inactive Brightness,” the prompt and the current setting (0 to 100 percent) will be highlighted. Press <up> or <down> to change the brightness of the LED illumination during inactivity. Pressing <enter> will save the displayed setting and return you to the unhighlighted “Inactive Brightness” prompt. From the “Inactive Brightness” prompt, use <up> to proceed to the next prompt, “Control Enabled”.

Control Enabled (checkbox)

If <enter> is pressed at the “Control Enabled” prompt, the box will toggle between checked (enable control) or unchecked (disable control). If enabled, this means that the lighting panels of the vender will be turned off during the programmed time blocks. Pressing <enter> will save the displayed setting and return you to the unhighlighted “Control Enabled” prompt. From the “Control Enabled” prompt, use <up> to proceed to the next prompt, “Start Days”.

Start Days (checkboxes)

If <enter> is pressed at the “Start Days” prompt, the controller will enter the start lighting control days setting routing. Pressing <exit> at this point will return you to the “Start Days” prompt without saving any changes. Use <up> to proceed to the next prompt, “Start Time.”

If <enter> is pressed at the “Start Days” prompt, the display will show Sunday, the first day of the week, followed by a box. Press <up> or <down> to scroll through each day of the week or “All Days”. If <enter> is pressed at the day of the week, the box will be checked (lighting control timer enabled for that day) or unchecked (lighting control timer disabled for that day). Pressing <enter> again will save the displayed setting and return you to the unhighlighted day name. Pressing <exit> will return the controller to the “Start Days” prompt. Press <up> to proceed to the next prompt, “Start Time”.

SECTION 3: Vender Programming

Start Time (<enter>, highlight, key in time)

If <enter> is pressed at the “Start Time” prompt, the controller will enter the start lighting control time setting routing. This time will be displayed in a 24-hour format. The left two digits of the display show the current hour setting; the right two digits show the current minutes. The hour setting will be flashing. Pressing <up> or <down> at this point will increase or decrease the hour setting. If <enter> is pressed, the minute setting will flash. Pressing <up> or <down> at this point will increase or decrease the minutes setting. Pressing <enter> again will save the displayed hour and minutes setting and return you to the unhighlighted “Start Time” prompt. Use <up> to proceed to the next prompt, “Stop Days.”

Stop Days (checkboxes)

If <enter> is pressed at the “Stop Days” prompt, the controller will enter the stop lighting control days setting routing. Pressing <exit> at this point will return you to the “Stop Days” prompt without saving any changes. Use <up> to proceed to the next prompt, “Stop Time.”

If <enter> is pressed at the “Stop Days” prompt, the display will show Sunday, the first day of the week, followed by a box. Press <up> or <down> to scroll through each day of the week or “All Days”. If <enter> is pressed at the day of the week, the box will be checked (lighting control timer enabled for that day) or unchecked (lighting control timer disabled for that day). Pressing <enter> again will save the displayed setting and return you to the unhighlighted day name. Pressing <exit> will return the controller to the “Stop Days” prompt. Press <up> to proceed to the next prompt, “Stop Time”.

Stop Time (<enter>, highlight, key in time)

If <enter> is pressed at the “Stop Time” prompt, the controller will enter the start lighting control time setting routing. This time will be displayed in a 24-hour format. The left two digits of the display show the current hour setting; the right two digits show the current minutes. The hour setting will be flashing. Pressing <up> or <down> at this point will increase or decrease the hour setting. If <enter> is pressed, the minute setting will flash. Pressing <up> or <down> at this point will increase or decrease the minutes setting. Pressing <enter> again will save the displayed hour and minutes setting and return you to the unhighlighted “Stop Time” prompt. Use <exit> to return to the “Lighting Control” prompt.

Selection Block 1

Selection Block 2

If <enter> is pressed at the “Selection Block X” prompt (where X = 1 or 2), the controller will enter the selection blocking control mode. Using <up> or <down>, you can cycle through the various selection blocking control settings. If <exit> is pressed, the controller will return to the “Selection Block X” prompt. From this prompt, press <up> to proceed to the next prompt, “Selection Discount X”.

Enable

If <enter> is pressed at the “Enable” prompt, the box will toggle between checked (enable blocking) or unchecked (disable blocking). If enabled, this means that active programmed selections will not be allowed to vend during programmed time blocks and a “No Sale Until xx:xx” message will be displayed. Pressing <enter> will save the displayed setting and return you to the unhighlighted “Enable” prompt. From the “Enable” prompt, use <up> to proceed to the next prompt, “Start Days”.

Start Days

If <enter> is pressed at the “Start Days” prompt, the controller will enter the start selection blocking control days setting routing. Pressing <exit> at this point will return you to the “Start Days” prompt without saving any changes. Use <up> to proceed to the next prompt, “Start Time.”

If <enter> is pressed at the “Start Days” prompt, the display will show Sunday, the first day of the week, followed by a box. Press <up> or <down> to scroll through each day of the week or “All Days”. If <enter> is pressed at the day of the week, the box will be checked (selection blocking control timer enabled for that day) or unchecked (selection blocking control timer disabled for that day). Pressing <enter> again will save the displayed setting and return you to the unhighlighted day name. Pressing <exit> will return the controller to the “Start Days” prompt. Press <up> to proceed to the next prompt, “Start Time”.

SECTION 3: Vender Programming

Start Time

If <enter> is pressed at the “Start Time” prompt, the controller will enter the start selection blocking control time setting routing. This time will be displayed in a 24-hour format. The left two digits of the display show the current hour setting; the right two digits show the current minutes. The hour setting will be flashing. Pressing <up> or <down> at this point will increase or decrease the hour setting. If <enter> is pressed, the minute setting will flash. Pressing <up> or <down> at this point will increase or decrease the minutes setting. Pressing <enter> again will save the displayed hour and minutes setting and return you to the unhighlighted “Start Time” prompt. Use <up> to proceed to the next prompt, “Stop Days.”

Stop Days

If <enter> is pressed at the “Stop Days” prompt, the controller will enter the stop selection blocking control days setting routing. Pressing <exit> at this point will return you to the “Stop Days” prompt without saving any changes. Use <up> to proceed to the next prompt, “Stop Time.”

If <enter> is pressed at the “Stop Days” prompt, the display will show Sunday, the first day of the week, followed by a box. Press <up> or <down> to scroll through each day of the week or “All Days”. If <enter> is pressed at the day of the week, the box will be checked (selection blocking control timer enabled for that day) or unchecked (selection blocking control timer disabled for that day). Pressing <enter> again will save the displayed setting and return you to the unhighlighted day name. Pressing <exit> will return the controller to the “Stop Days” prompt. Press <up> to proceed to the next prompt, “Stop Time”.

Stop Time

If <enter> is pressed at the “Stop Time” prompt, the controller will enter the start selection blocking control time setting routing. This time will be displayed in a 24-hour format. The left two digits of the display show the current hour setting; the right two digits show the current minutes. The hour setting will be flashing. Pressing <up> or <down> at this point will increase or decrease the hour setting. If <enter> is pressed, the minute setting will flash. Pressing <up> or <down> at this point will increase or decrease the minutes setting. Pressing <enter> again will save the displayed hour and minutes setting and return you to the unhighlighted “Stop Time” prompt. Use <up> to proceed to the next prompt, “Blocked Selections”.

Blocked Selections

If <enter> is pressed at the “Blocked Selections” prompt, the display will show “All”, followed by a box. If <enter> is pressed at “All”, the box will toggle between checked (to block all selections at once) or unchecked (to block only certain selections). Press <enter> to save the status and return to the unhighlighted “All” display. Press <up> to proceed to the next menu item, “Shelf”.

If <enter> is pressed at “Shelf”, all the available shelf numbers will be displayed, followed by a box. If <enter> is pressed at a desired shelf number, the box for that shelf will toggle between checked (to block all selections on that shelf) or unchecked (to block only certain selections on that shelf or none). Pressing <enter> will save the status and return the display to the unhighlighted shelf number. Press <up> or <down> to scroll through each available shelf number. Press <exit> to return to the “Shelf” prompt within “Blocked Selections”. Press <up> to proceed to the next menu item, “Selection”.

If <enter> is pressed at “Selection”, all the available selection numbers will be displayed, followed by a box. If <enter> is pressed at a desired selection number, the box for that selection will toggle between checked (to block that selection) or unchecked (to not block that selection, leaving it available for sales at all times). Pressing <enter> will save the status and return the display to the unhighlighted selection number. Press <up> or <down> to scroll through each available selection number. Press <exit> to return to the “Selection” prompt within “Blocked Selections”. Press <exit> again to return to the “Selection Blocking X” prompt.

SECTION 3: Vender Programming

Selection Discount 1

Selection Discount 2

Selection Discount 3

If <enter> is pressed at the “Selection Discount X” prompt (where X = 1, 2, or 3), the controller will enter the discount control mode. Using <up> or <down>, the user can cycle through the various discount control settings. If <exit> is pressed, the controller will return to the “Selection Discount X” prompt. Use <up> to proceed to the next prompt, “Override Switch”.

Enable

Upon first entry into “Selection Discount X”, the controller will display “Enable”. If <enter> is pressed at the “Enable” prompt, the box will toggle between checked (enable discount sales) or unchecked (disable discount sales). If enabled, this means that active selections will be discounted by the programmed discount amount during the programmed time blocks. Pressing <enter> will save the displayed setting and return you to the unhighlighted “Enable” prompt. From the “Enable” prompt, use <up> to proceed to the next prompt, “Start Days”.

Start Days

If <enter> is pressed at the “Start Days” prompt, the controller will enter the start discounting control days setting routing. Pressing <exit> at this point will return you to the “Start Days” prompt without saving any changes. Use <up> to proceed to the next prompt, “Start Time.”

If <enter> is pressed at the “Start Days” prompt, the display will show Sunday, the first day of the week, followed by a box. Press <up> or <down> to scroll through each day of the week or “All Days”. If <enter> is pressed at the day of the week, the box will be checked (discounting control timer enabled for that day) or unchecked (discounting control timer disabled for that day). Pressing <enter> again will save the displayed setting and return you to the unhighlighted day name. Pressing <exit> will return the controller to the “Start Days” prompt. Press <up> to proceed to the next prompt, “Start Time”.

Start Time

If <enter> is pressed at the “Start Time” prompt, the controller will enter the start discounting control time setting routing. This time will be displayed in a 24-hour format. The left two digits of the display show the current hour setting; the right two digits show the current minutes. The hour setting will be flashing. Pressing <up> or <down> at this point will increase or decrease the hour setting. If <enter> is pressed, the minute setting will flash. Pressing <up> or <down> at this point will increase or decrease the minutes setting. Pressing <enter> again will save the displayed hour and minutes setting and return you to the unhighlighted “Start Time” prompt. Use <up> to proceed to the next prompt, “Stop Days.”

Stop Days

If <enter> is pressed at the “Stop Days” prompt, the controller will enter the stop discounting control days setting routing. Pressing <exit> at this point will return you to the “Stop Days” prompt without saving any changes. Use <up> to proceed to the next prompt, “Stop Time.”

If <enter> is pressed at the “Stop Days” prompt, the display will show Sunday, the first day of the week, followed by a box. Press <up> or <down> to scroll through each day of the week or “All Days”. If <enter> is pressed at the day of the week, the box will be checked (discounting control timer enabled for that day) or unchecked (discounting control timer disabled for that day). Pressing <enter> again will save the displayed setting and return you to the unhighlighted day name. Pressing <exit> will return the controller to the “Stop Days” prompt. Press <up> to proceed to the next prompt, “Stop Time”.

Stop Time

If <enter> is pressed at the “Stop Time” prompt, the controller will enter the start discounting control time setting routing. This time will be displayed in a 24-hour format. The left two digits of the display show the current hour setting; the right two digits show the current minutes. The hour setting will be flashing. Pressing <up> or <down> at this point will increase or decrease the hour setting. If <enter> is pressed, the minute setting will flash. Pressing <up> or <down> at this point will increase or decrease the minutes setting. Pressing <enter> again will save the displayed hour and minutes setting and return you to the unhighlighted “Stop Time” prompt. Use <up> to proceed to the next prompt, “Discounted Selections”.

SECTION 3: Vender Programming

Discounted Selections

If <enter> is pressed at the “Discounted Selections” prompt, the display will show “All”, followed by a box. If <enter> is pressed at “All”, the box will toggle between checked (to discount all selections at once) or unchecked (to discount only certain selections). Press <enter> to save the status and return to the unhighlighted “All” display. Press <up> to proceed to the next menu item, “Shelf”.

If <enter> is pressed at “Shelf”, all the available shelf numbers will be displayed, followed by a box. If <enter> is pressed at a desired shelf number, the box for that shelf will toggle between checked (to discount all selections on that shelf) or unchecked (to discount only certain selections on that shelf or none). Pressing <enter> will save the status and return the display to the unhighlighted shelf number. Press <up> or <down> to scroll through each available shelf number. Press <exit> to return to the “Shelf” prompt within “Discounted Selections”. Press <up> to proceed to the next menu item, “Selection”.

If <enter> is pressed at “Selection”, all the available selection numbers will be displayed, followed by a box. If <enter> is pressed at a desired selection number, the box for that selection will toggle between checked (to discount that selection) or unchecked (to not discount that selection, leaving it at full price at all times). Pressing <enter> will save the status and return the display to the unhighlighted selection number. Press <up> or <down> to scroll through each available selection number. Press <exit> to return to the “Selection” prompt within “Discounted Selections”. Press <up> to proceed to the next prompt, “Less Amount”.

Less Amount

If <enter> is pressed at the “Less Amount” prompt, the current four-digit discount amount (00.00 – 99.95) will be displayed. Using <up> or <down> will increase or decrease this amount in increments of the least coin tube value. Pressing <enter> will save the setting and return to the unhighlighted “Less Amount” prompt. Pressing <exit> will return you to the “Less Amount” prompt without saving any changes. From the “Less Amount” prompt, use <exit> to return to the “Selection Discount X” prompt. (Note: If the discount amount is greater than the sales price for a given selection, the selection will free-vend.)

Override Switch

If the controller is equipped with a key switch, it can be used to override some of the settings stored for normal operation of the vender. The key switch can be programmed to control one or several features simultaneously. If a feature is enabled in this menu, that feature will override normal machine operation when the switch is activated.

If <enter> is pressed at the “Override Switch” prompt the controller will enter the override configuration setting mode by displaying “Free Vend”, followed by a box. Using <up> or <down> will allow you to cycle through all available override configuration options. If <exit> is pressed at any time during this operation, the controller will return to the “Override Switch” prompt. From the “Override Switch” prompt, press <up> to proceed to the next prompt, “Apply Update”.

The following options can be selected for override control:

- Free Vend

If <enter> is pressed at the “Free Vend” prompt, the box will toggle between checked or unchecked. When the desired status is displayed, pressing <enter> will save that status and return you to the unhighlighted “Free Vend” display. If “Free Vend” is enabled, “Free” will be displayed immediately after the POS message.

Unchecked: free vend will be disabled when the key switch is activated.

Checked: free vend will be enabled when the key switch is activated.

Note: All free vends will increase free vend MIS counters (VA3).

SECTION 3: Vender Programming

- **No Vend**

If <enter> is pressed at the “No Vend” prompt, the box will toggle between checked or unchecked. When the desired status is displayed, pressing <enter> will save that status and return you to the unhighlighted “No Vend” display. If “No Vend” is enabled, no selections will be allowed to vend and a “No Sale” message will be displayed.

Unchecked: no vend will be disabled when the key switch is activated.

Checked: no vend will be enabled when the key switch is activated (all selections blocked for sales).

Note: If both “Free Vend” and “No Vend” are enabled, “No Vend” will be given priority (no vending will be allowed).

- **Blocking Disable**

If <enter> is pressed at the “Blocking Disable” prompt, the box will toggle between checked or unchecked. When the desired status is displayed, pressing <enter> will save that status and return you to the unhighlighted “Blocking Disable” display. If “Blocking Disable” is enabled, all programmed time blocks will be overridden by the key switch, allowing sales at all times.

Checked: selection blocking will be disabled when the key switch is activated (vending at all times).

Unchecked: selection blocking will be enabled when the key switch is activated.

Note: “Blocking Disable” is used in conjunction with “Selection Block X” programming menus.

- **Discounting Disable**

If <enter> is pressed at the “Discounting Disable” prompt, the box will toggle between checked or unchecked. When the desired status is displayed, pressing <enter> will save that status and return you to the unhighlighted “Discounting Disable” display. If “Discounting Disable” is enabled, all programmed discount sales timers will be overridden by the key switch, ensuring selections will sell at full price at all times.

Checked: discounting will be disabled when the key switch is activated.

Unchecked: discounting will be enabled when the key switch is activated (normal function).

- **Lighting Control Disable**

If <enter> is pressed at the “Lighting Control Disable” prompt, the box will toggle between checked or unchecked. When the desired status is displayed, pressing <enter> will save that status and return you to the unhighlighted “Lighting Control Disable” display. If “Lighting Control Disable” is enabled, all programmed lighting control timers will be overridden by the key switch, ensuring illumination at all times.

Checked: lighting control will be disabled when the key switch is activated (illumination at all times).

Unchecked: lighting control will be enabled when the key switch is activated (normal function).

- **Refrigeration Disable**

If <enter> is pressed at the “Refrigeration X” prompt, the box will toggle between checked or unchecked. When the desired status is displayed, pressing <enter> will save that status and return you to the unhighlighted “the box will toggle between checked or unchecked. When the desired status is displayed, pressing <enter> will save that status and return you to the unhighlighted “Refrigeration Disable”.

Checked: refrigeration blocking will be disabled when the key switch is activated (allowing normal refrigeration at all times).

Unchecked: refrigeration blocking will be enabled when the key switch is activated.

SECTION 3: Vender Programming

Apply Update

If <enter> is pressed at the “Apply Update” prompt, the controller will search for a USB-connected software update device.

Revert to Defaults (<enter>, highlighted)

If <enter> is pressed at the “Revert to Defaults” prompt, the prompt will be highlighted, and the bottom of the display will advise the available options (“Cancel” or “Enter”). Press <exit> to cancel and unhighlight the prompt, or press <enter> to continue the “Revert to Defaults” function. “Are you sure?” will be displayed. If <exit> is pressed at this prompt, no settings will be cleared, and the display will return to the “Revert to Defaults” prompt. If <enter> is pressed, all system configurations will be returned to their default values (factory settings), and the display will show “VMC Re-initialized” for approximately three seconds. The display will then return to the “Revert to Defaults” prompt. Prices, Configurations, and time-assigned features will all be reset to defaults. DEX accounting fields, real-time clock settings, and error conditions will not be reset. Use <up> to return to the first menu prompt, “Errors”.

SECTION 4: Vender Maintenance

Vender Maintenance

What to Clean

CAUTION: *Electrical and electronic components should NEVER be subjected to water.*

Belts: The belts should always be kept clean and free of debris to ensure efficient operation, as well as to extend the life of the belts.

Cells: Make sure the cells are free of dirt, syrup, and debris. Build-up of foreign material, especially syrup from broken or leaking packages, can cause the cell to stick and adversely affect the cell's performance. Use warm soapy water or other food grade cleaning agents to maintain a clean smooth surface. Also make sure that the cells are level and seated properly in the tracks that they slide into.

Condenser and Evaporator Coils: For efficient operation, the condenser and evaporator coils must be kept clear of any dirt or foreign materials. Clean dirt and debris from the condenser and evaporator coils with a small light-bristled brush, vacuum cleaner, or compressed air. This will help to ensure an extended unit life.

VMC: The vender's control board (VMC) should always be enclosed by its cover to protect it. Routine cleaning is not necessary but, if desired, the board area may be blown out with compressed air.

Delivery Bin: Make sure that the delivery bin remains clean and free of any debris or other objects that may block the optic sensors. Bottles sometimes have a tendency to lose their labels, which may be left in the delivery bin. If objects are left in the bin and the sensors are blocked, the board will assume there is a package in the bin and will not deliver product to the bin.

Elevator Arm and Cup Tracks: The elevator arm and cup assemblies travel in aluminum tracks that guide these components. Make sure that these tracks are kept clean and free from foreign material such as dirt, syrup, or other debris. Use a wet cloth to wipe these tracks clean. Avoid using any type of silicone or lubricant, as they may tend to collect dirt and will adversely affect performance.

Product Cup: The cup floor should be kept clean and free of syrup.

Lubrication

Latch Strike Nut: The latch strike nut **should** be lubricated.

Refrigeration Unit: The refrigeration unit is a sealed system that does not require any lubrication. Also, the condenser and evaporator fan motors do not require any lubrication.

Preventive Maintenance

Vender Leveling: Make sure that the vender is level when placed on site. If the vender is not properly leveled it can begin to accumulate standing water, which over a period of time may begin to freeze and will eventually freeze the evaporator. Another problem that may occur from an unlevelled vender will be improper vending, which would include but not be limited to product not vending from cell, product vending slowly from cell, product not being delivered to the delivery bin, or product jamming.

SECTION 5: Troubleshooting

Troubleshooting

The RVV 700 is equipped with a self-diagnostic feature to aid in the repair and maintenance of the vender. When servicing the vender, pay close attention to the digital display. When the vender door is opened, the display will begin showing any error codes that are stored in memory. If there are no errors, the display will show “No Errors.”

To enter the Service Mode, press and release the blue Service Mode Button located on the VMC board. The display will show “Errors Were Detected” if there are recorded errors. If **<enter>** is pressed at the “Errors Were Detected” prompt, the controller will enter the error display mode. The display will show the first error summary code that has occurred.

If **<enter>** is pressed, the controller will display the detailed error for the summary code. The **<up>** and **<down>** buttons will cycle through any remaining error detail codes. If **<exit>** is pressed while displaying any *detailed* code, the controller will return to the summary code. If **<exit>** is pressed while displaying any *summary* code, the controller will return to the code level (“No Errors” or “Errors Were Detected”).

***NOTE:** When troubleshooting errors with peripherals, the appropriate peripheral service manual(s) should also be consulted for further tests and corrective actions.*

Troubleshooting by Error Codes

SECTION 6: Parts Catalog

RVV 700 Main Controller and Harnesses

ITEM NO.	DESCRIPTION	PART NUMBER
•	Vender Main Controller, RVV 700	836327
•	Harness, Serial Changer.....	842261
•	Harness, X-axis, Large Cable Chain to Cup and Motor	855027
•	In-line GFCI Cordset	855045
•	Harness, Door Switch to VMC, RVV 700	855049
•	Harness, Membrane Switch Keypad, RVV 700	855050
•	Harness, VMC Energy Management to Power Supply Module, RVV 700	855051
•	Harness, VMC to Port, RVV 700.....	855052
•	Harness, VMC to Display, RVV 700	855053
•	Harness, Port Assembly to Guillotine Door, RVV 700.....	855054
•	Harness, On / Off Switch to Relay Board / Transformers, RVV700	855055
•	Harness, Relay Board to Output Connector, RVV 700	855056
•	Harness, Relay Board to Relay Control Input, RVV 700.....	855057
•	Harness, Fuses to Power Supply Board, RVV 700 (2 per vender)	855058
•	Harness, Power Supply Board to VMC Power Output, RVV 700.....	855059
•	Harness, Transformer to Fuses, RVV 700 (2 per vender).....	855060
•	Harness, Appliance Inlet to On / Off Switch, RVV700.....	855061
•	Harness, Power Module to VMC / Transaction Light, RVV700	855062
•	Harness, Relay Output to Bulkhead, RVV 700	855063
•	Harness, Bulkhead to Refrigeration Unit, RVV 700	855064
•	Harness, Jumper Input Transformer, RVV 700	855071
•	Harness, Jumper Output Transformer, RVV 700	855072
•	Ground Wire, Power Module, RVV 700 (2 per vender).....	855074
•	Ground Wire, Transaction Door, RVV 700	855076

SECTION 6: Parts Catalog

LED Assemblies

ITEM NO.	DESCRIPTION	PART NUMBER
•	LED, 48"	841110
•	LED, 24"	841111
•	LED, 12"	841112
•	LED, 4"	841113

SECTION 6: Parts Catalog

RVV 700 Vend Motors

ITEM NO.	DESCRIPTION	PART NUMBER
•	Stepper Motor, X-axis	839060
•	Stepper Motor, Y-axis	839134

SECTION 6: Parts Catalog

RVV 700 Cup Assembly 854048

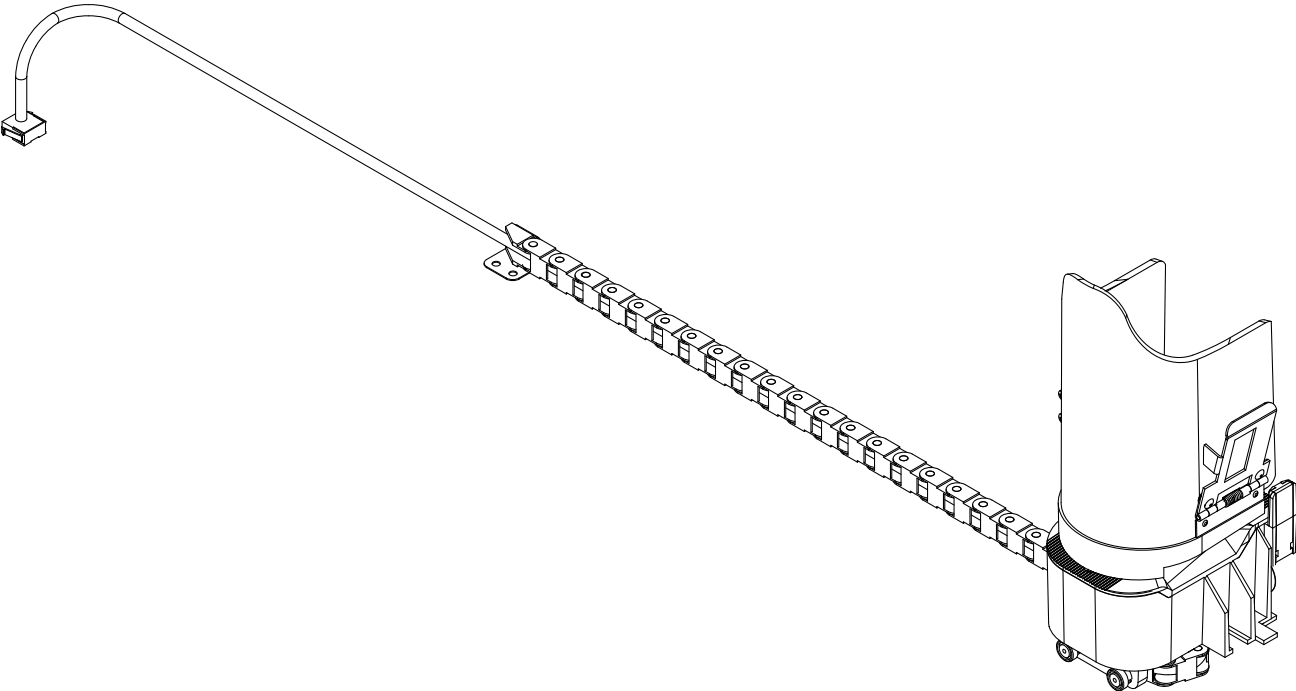

SECTION 6: Parts Catalog

Elevator Assembly 408820

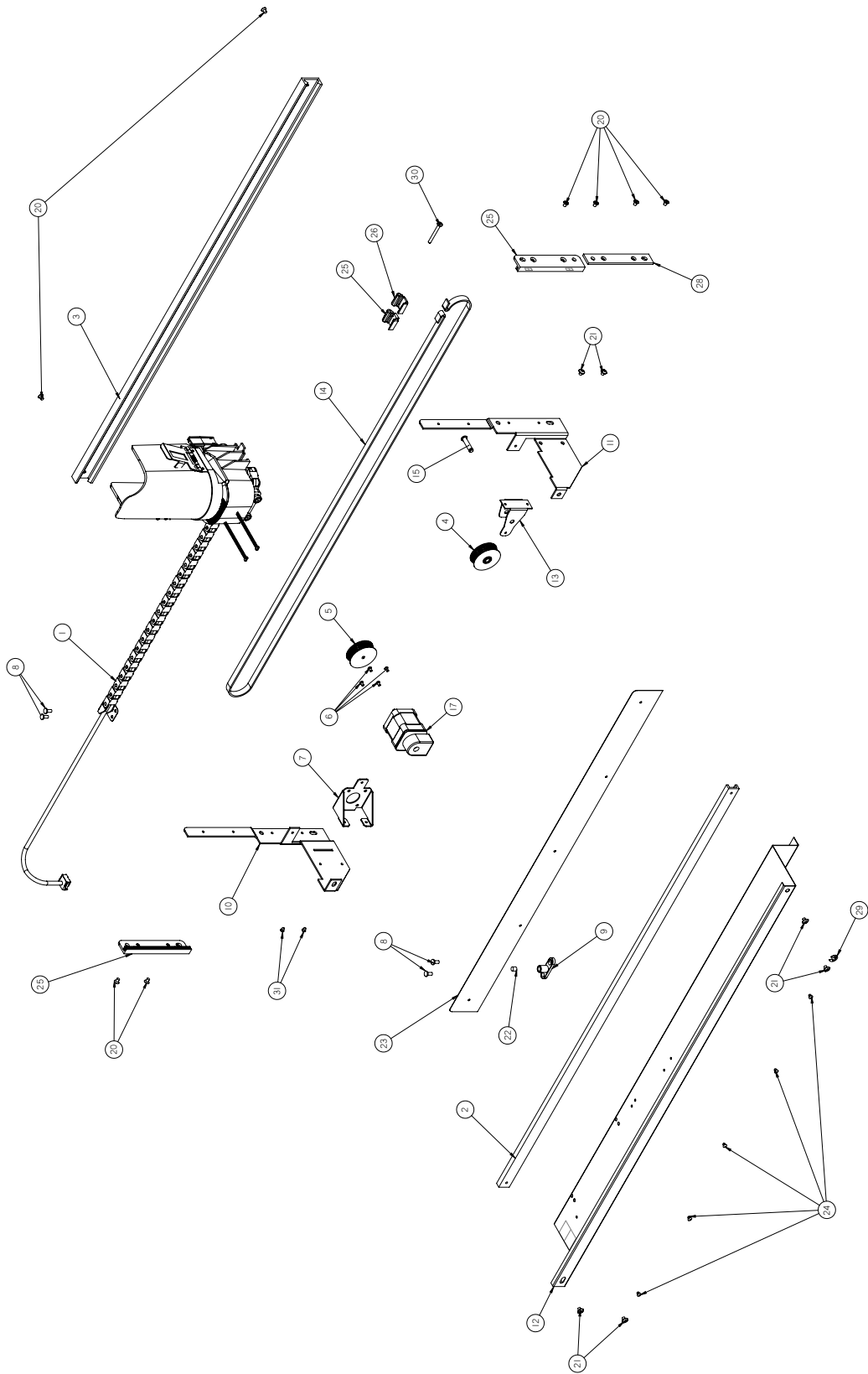

SECTION 6: Parts Catalog

Elevator Assembly 408820

ITEM NO.	DESCRIPTION	PART NUMBER
1	Cup Assembly	854048
2	Guide Rail RVV 700	813038
3	Vee Grooved Rail RVV 700.....	813037
4	Idler Pulley	815679
5	Drive Pulley, X-arm	815693
6	Screw, M3-0.5 x 6 mm PFH	901118
7	Motor Plate.....	408814
8	Screw, #8-32 x 3/8"	901011
9	--	
10	Elevator End, Motor Side	408818
11	Elevator End, Idler Side	408817
12	Elevator Cover	408819
13	Idler Bracket.....	408815
14	X-belt.....	816167
15	Elevator Idler Pin.....	906094
16	--	
17	X-motor RVV 700	839060
18	Magnet Holder, Milled	854089
19	--	
20	Screw, #8-32 x 0.25 FHMS	901153
21	Screw, #8-32 x 0.3125, Socket Cap.....	901177
22	Magnet, Positional	803098
23	Cable Chain Block	408816
24	Pop Rivet, 1/8" x 0.265 SS.....	908009
25	Belt Clamp Block.....	854083
26	Belt Clamp, Left	854081
27	Belt Clamp, Right	854082
28	Spacer RVV 700	408824
29	Ring, 1/4", External Type E	906013
30	Screw, #8-32 x 1.75" PH	901119
31	Pop Rivet, 1/8" x 0.328"	908007

SECTION 6: Parts Catalog

**Elevator / Cup Assembly
408821**

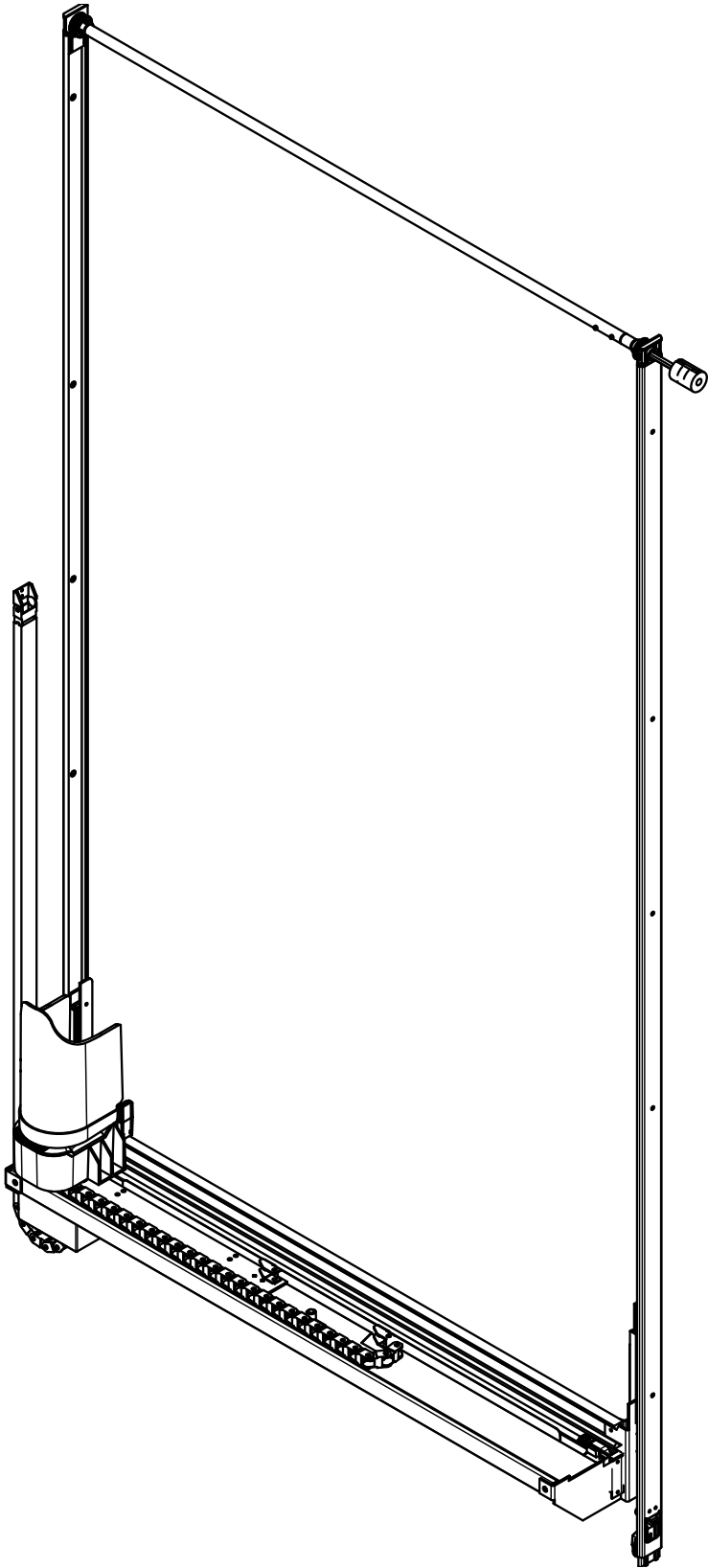

SECTION 6: Parts Catalog

**Guide Rail Assembly
854079**

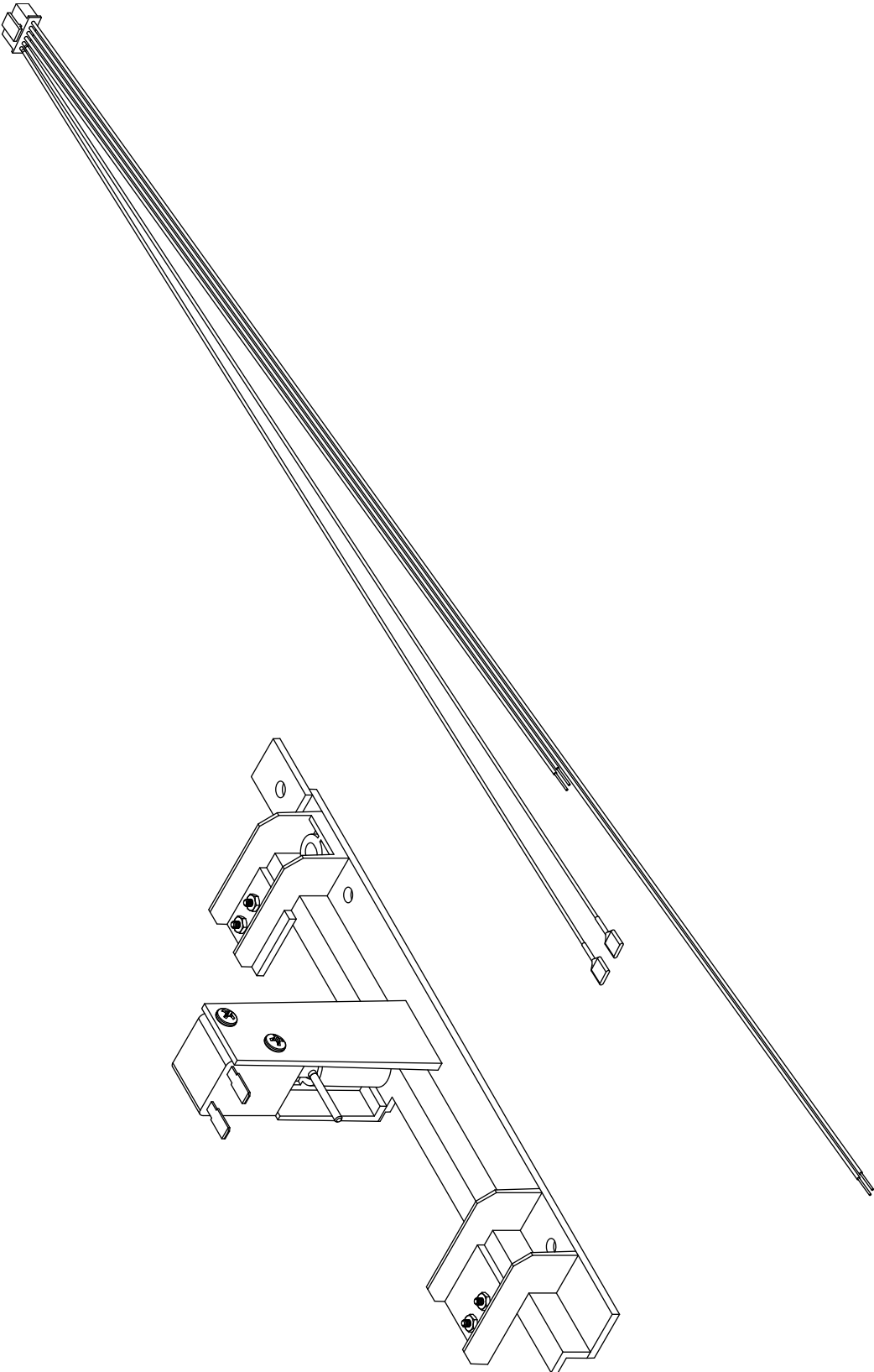

SECTION 6: Parts Catalog

Cabinet Assembly - View 1

Parts list for all Cabinet views located on page 52

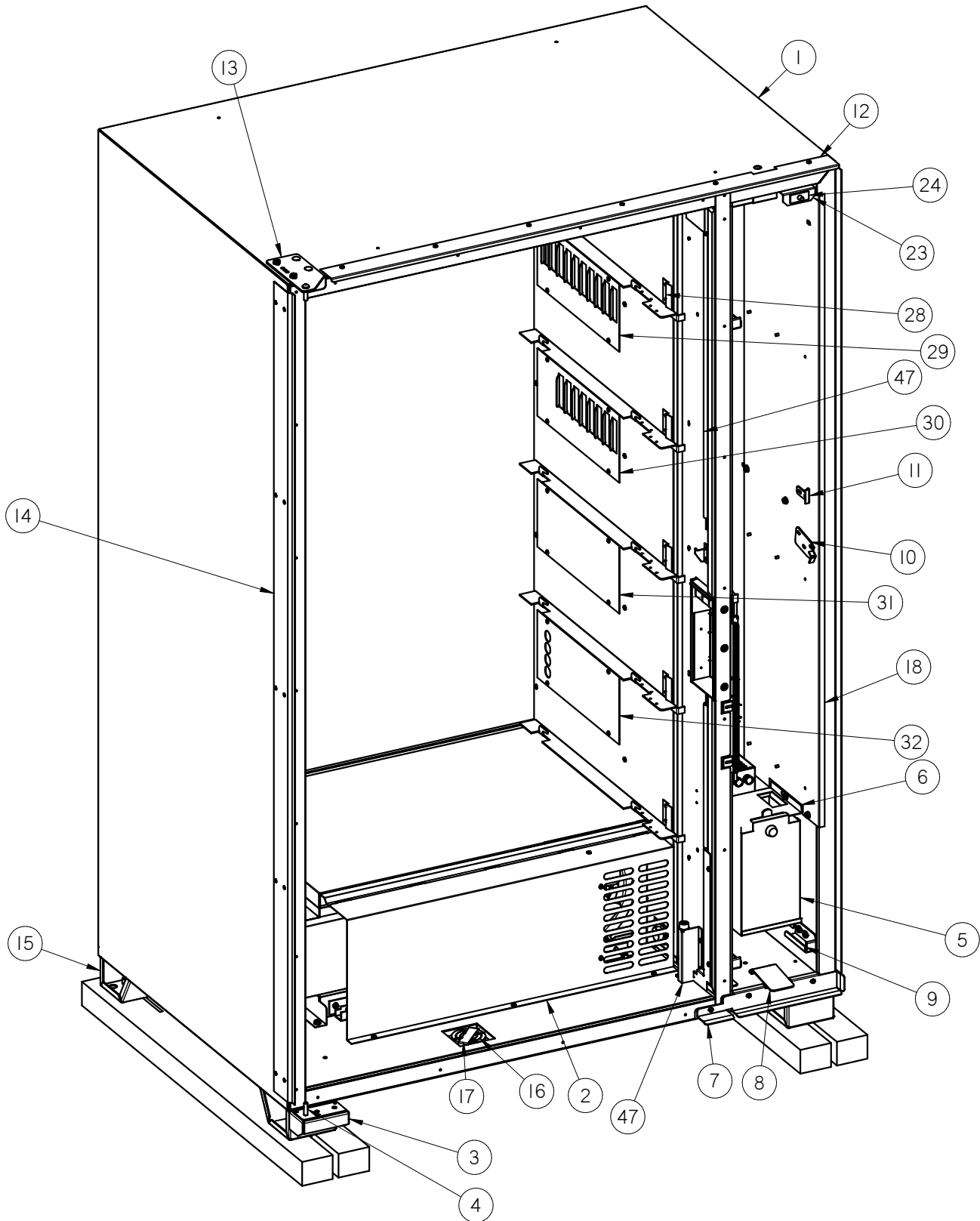

SECTION 6: Parts Catalog

Cabinet Assembly - View 2

Parts list for all Cabinet views located on page 52

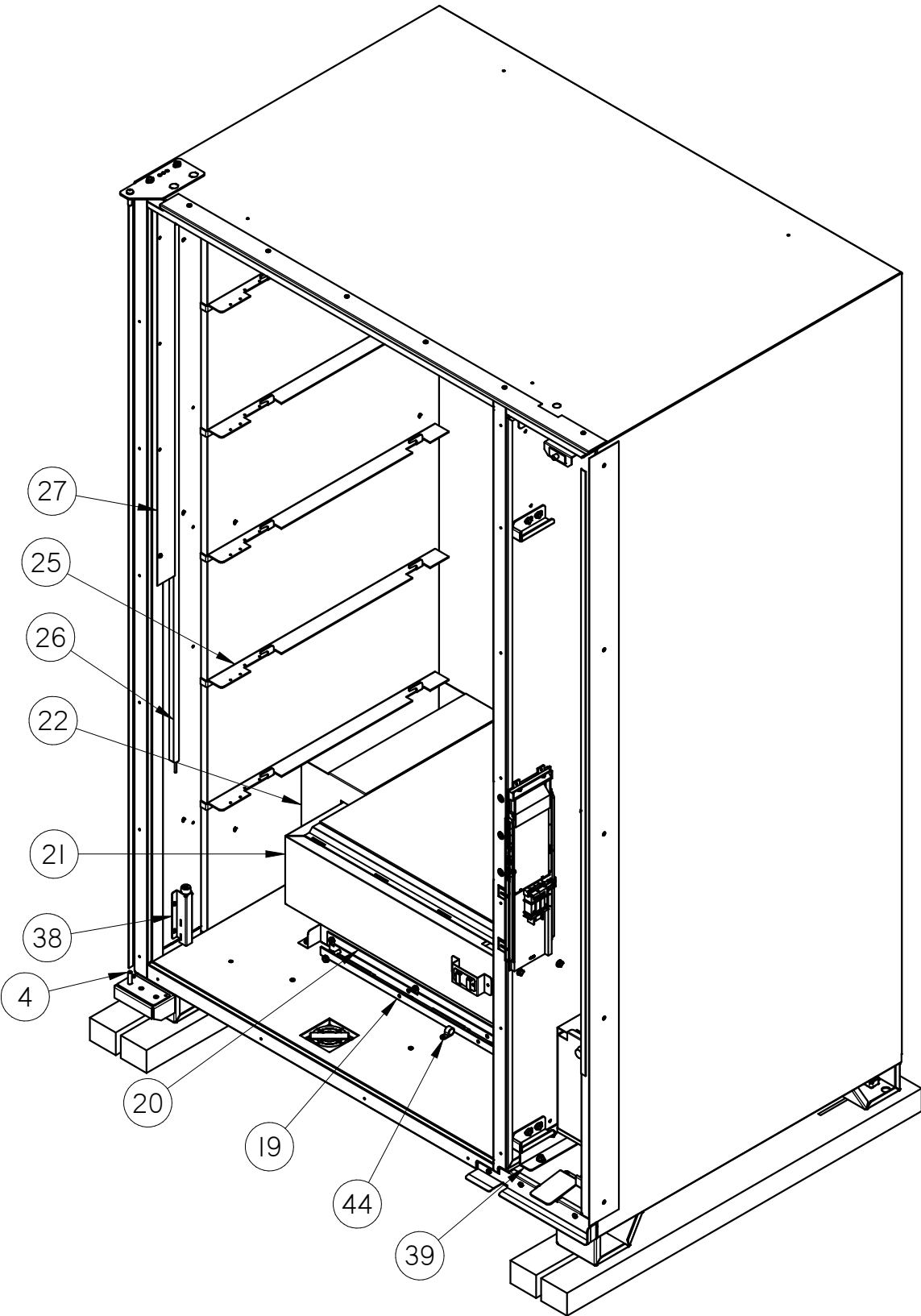

SECTION 6: Parts Catalog

Cabinet Assembly - View 3 *Parts list for all Cabinet views located on page 52*

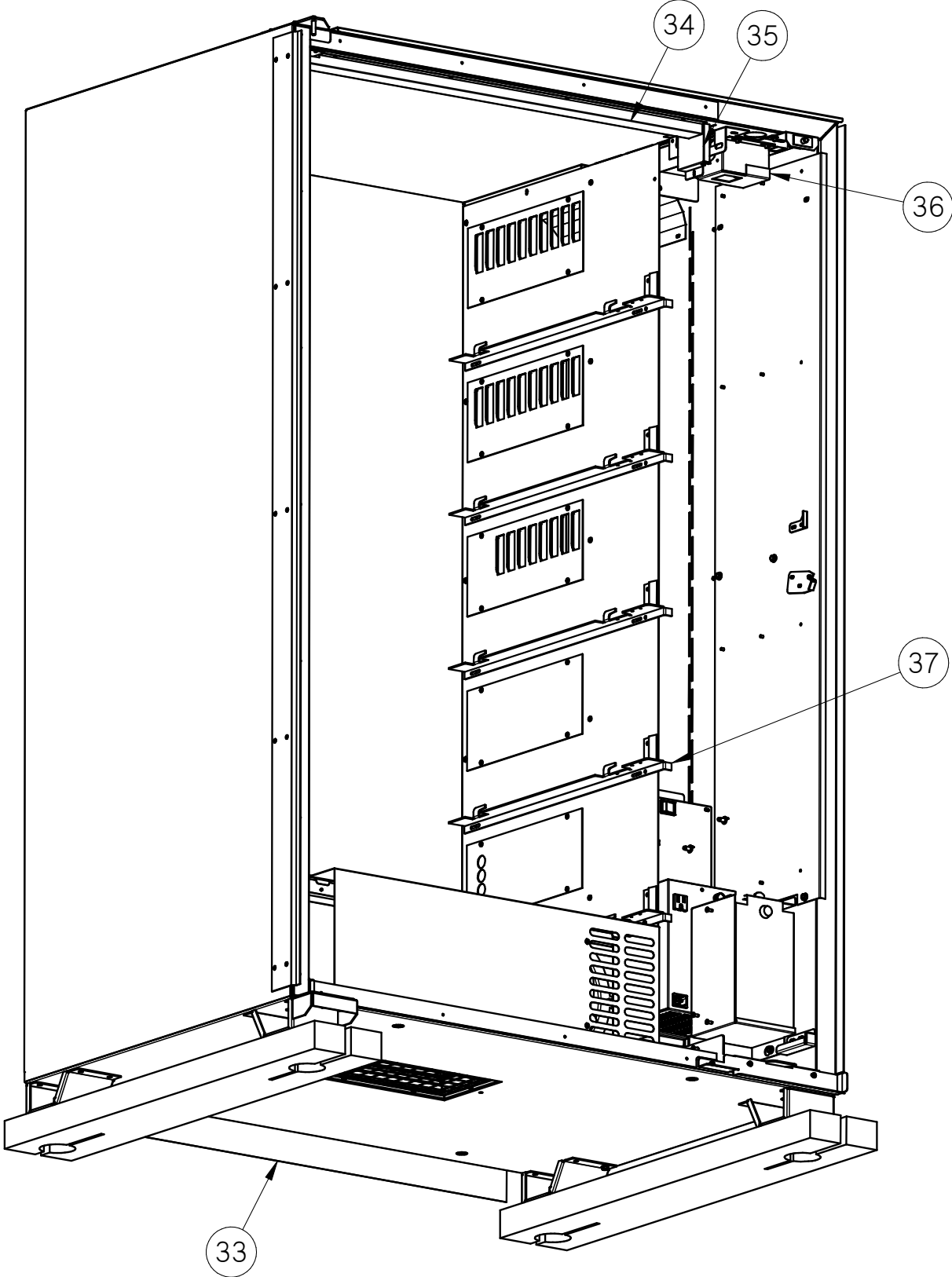

SECTION 6: Parts Catalog

Cabinet Assembly - View 4 Parts list for all Cabinet views located on page 52

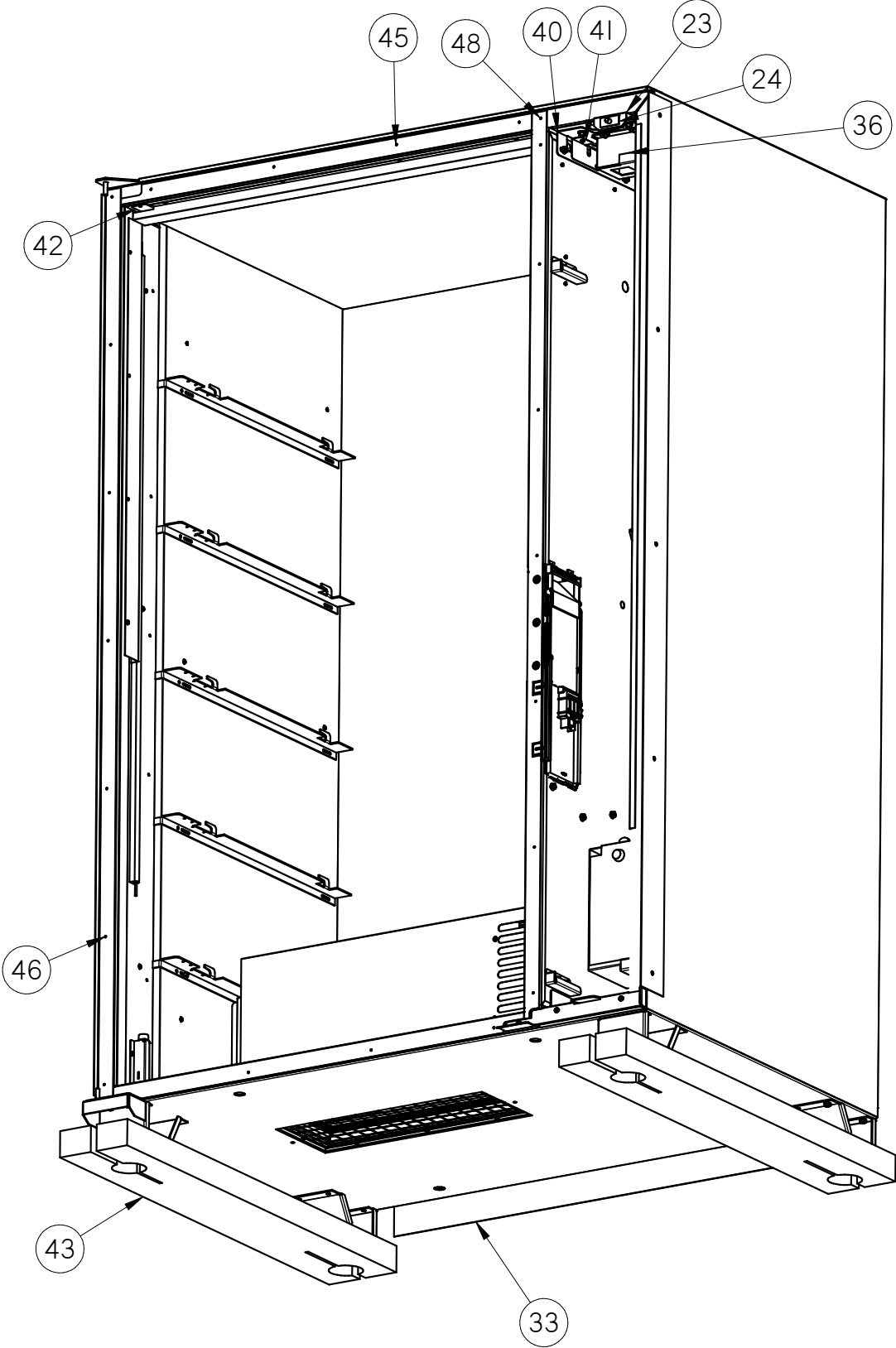

SECTION 6: Parts Catalog

Cabinet Assembly List Parts list for all Cabinet views on pages 48-51

ITEM	DESCRIPTION	P/N	ITEM	DESCRIPTION	P/N
1	CABINET FOAMED ASSY - RVV700	408230	32	AIR DUCT PLATE BTM - RVV700	408028
2	REFRIGERATION SHROUD ASSY RVV700	408431	33	CABINET BACK AIR CURTAIN RVV700	854080
3	LEVELING LEG SUPPORT W_HINGE W/A -	408223	34	TOP TANK WIRE COVER RVV700	408011
4	BTM. DOOR HINGE PLATE W/A	408217	35	TOP PARTITION WIRE COVER RVV700	408007
5	COIN BOX W/A RVV700	408587	36	MOUNT W/A, Y-MOTOR RVV700 GEN III	408802
6	COIN BOX HOUSING - RVV700	408578	37	SHELF SLIDE RIGHT SIDE RVV700	408704
7	LOWER DOOR LIFT / PRY ANGLE	408008	38	ELEVATOR BUMPER ASSY - LEFT RVV 700	408806
8	DOOR LIFT PLATE RVV700	408236	39	PARTITION MNTG ANGLE BTM - RVV700	408634
9	408037	SLIDER	40	PARTITION MNTG ANGLE TOP W/STUDS	408617
10	CENTER DOOR LATCH STRIKE	408582	41	WALL PLATE RVV 700	408622
11	PANEL LATCH STRIKE RVV700	408042	42	HINGE POCKET COVER - RVV700	408309
12	CABINET TOP VANDAL STRIP RVV700	408229	43	SKID BOARD RVV700	846129
13	GLASS DOOR HINGE TOP W/A	408224	44	CLAMP, PLASTIC WIRE HARN. 1/2" ID	916053
14	CABINET VANDAL PANEL RVV700	408006	45	CABINET BREAKER TRIM - TOP & BTM.	408226
15	LEVELING LEG SUPPORT W/A - RVV700	408213	46	CABINET BREAKER TRIM - SIDE RVV700	408227
16	BUBBLE LEVEL	916240	47	Part Name Required	Part
17	BUBBLE LEVEL CLAMP RVV700	408027	48	PARTITION BREAKER TRIM RVV700	408621
18	DOOR SLIDE PANEL W_STUDS RVV700	408528			
19	REFRIG. HOLD DOWN ANGLE RVV700	408438			
20	REFRIG. FRONT ANGLE RVV700	408437			
21	REFRIGERATION COVER ASSY RVV700	408416			
22	RETURN AIR BAFFLE ASSY RVV700	408436			
23	DOOR SWITCH BRACKET RVV700	408003			
24	SWITCH, PANEL MOUNT PUSH / PULL	835063			
25	SHELF SLIDE LEFT SIDE RVV700	408702			
26	LAMP, 48" "D" PROFILE FROSTED	841110			
27	LEFT SIDE CABINET WIRE COVER RVV700	408010			
28	SHELF SPACER RVV700	408706			
29	AIR DUCT PLATE -10 LOUVER RVV700	408022			
30	AIR DUCT PLATE -8 LOUVER RVV700	408021			
31	AIR DUCT FILLER PLATE RVV700	408020			

SECTION 6: Parts Catalog

Foamed Cabinet Assembly

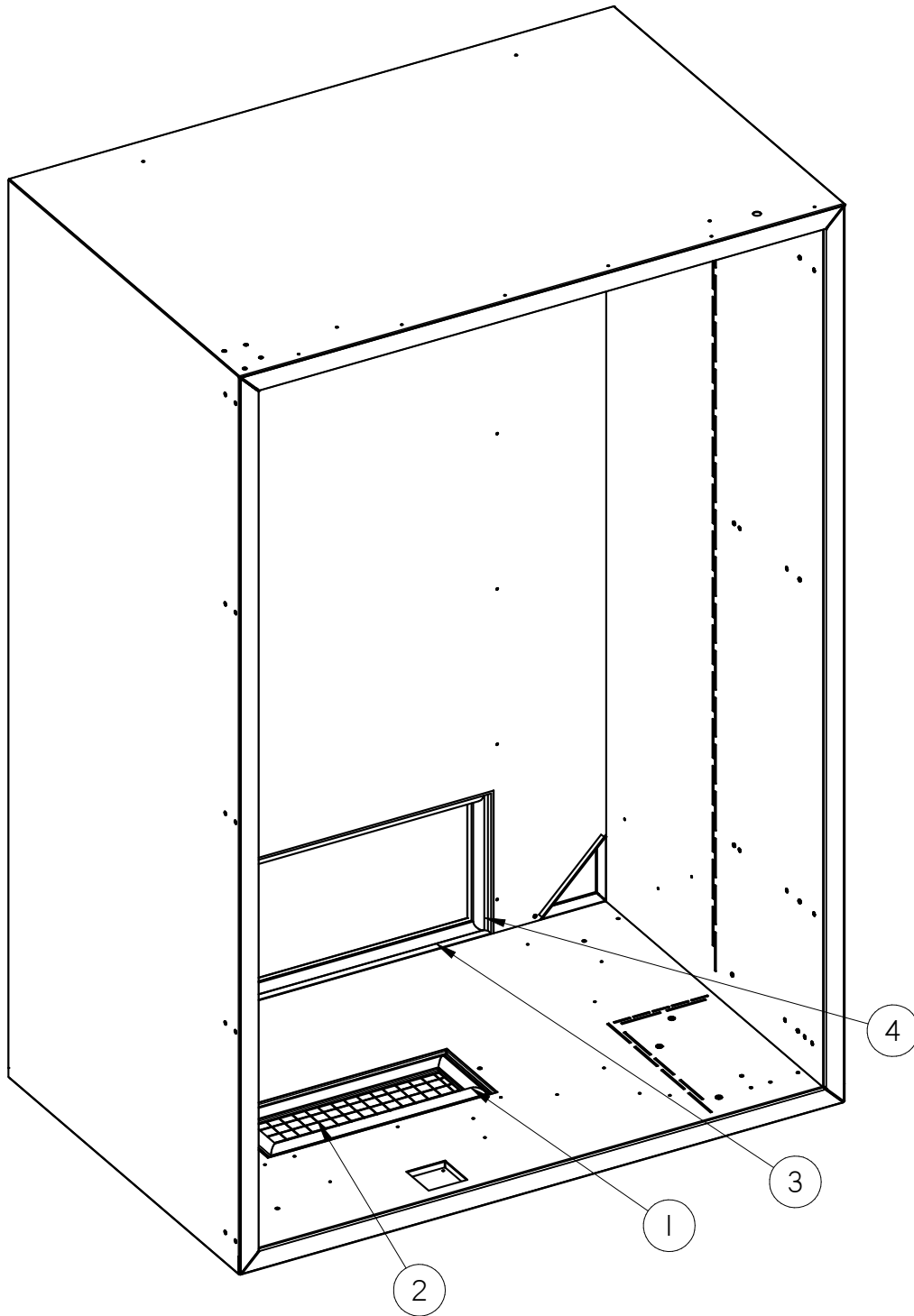

ITEM	DESCRIPTION	P/N
1	CASSETTE GASKET BTM. -	854062
2	CABINET BTM. SCREEN - RVV700	408328
3	GASKET, "D" CLOSED CELL. 28.00"	829090
4	GASKET, "D" CLOSED CELL. 10.50"	829089

SECTION 6: Parts Catalog

Access Panel Assembly

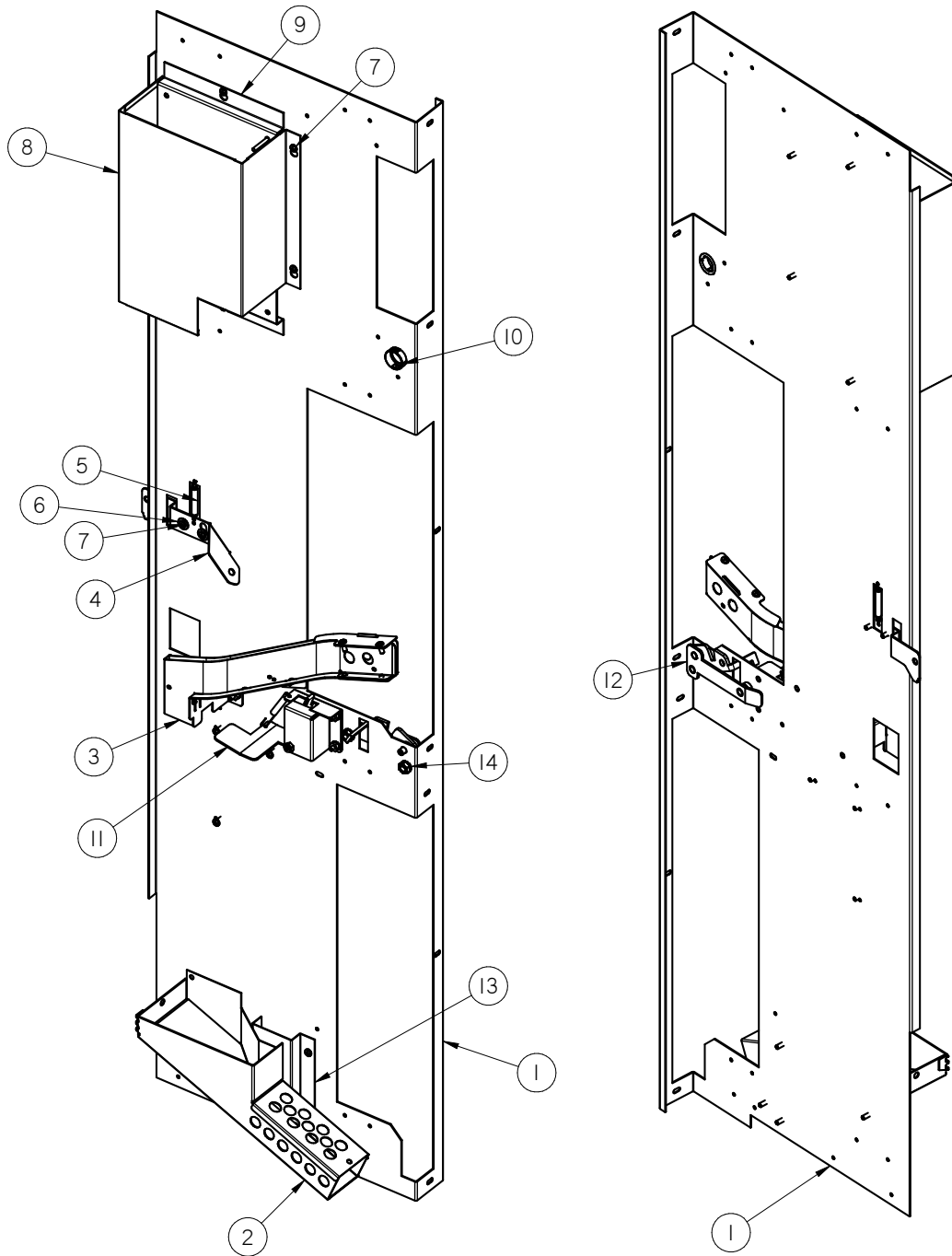

ITEM	DESCRIPTION	P/N	ITEM	DESCRIPTION	P/N
1	ACCESS PANEL W_STUDS RVV700	408584	8	CONTROL BOARD COVER RVV700	408553
2	COIN HOPPER ASSY RVV700	408590	9	BOARD MNTG. PANEL W_STUDS RVV700	408552
3	CABINET COIN CHUTE ASSY RVV700	408510	10	BUSHING, OPEN/CLOSED 3/4" ID	916071
4	PANEL LATCH RVV700 GEN III	408526	11	COIN RETURN LEVER ASSY RVV700	408556
5	BUTTON LEVER SPRING	914023	12	CENTER DOOR LATCH ASSY RVV700	408560
6	BUSHING, LOCKOUT - RVV2	916150	13	COIN BOX COIN CHUTE - RVV700 GEN III	408505
7	SCREW, #8-32 X 3/8 PH PAN HD	901011	14	1/4-20 KEPS NUT	905002

SECTION 6: Parts Catalog

Coin Return Cup Assembly 408565

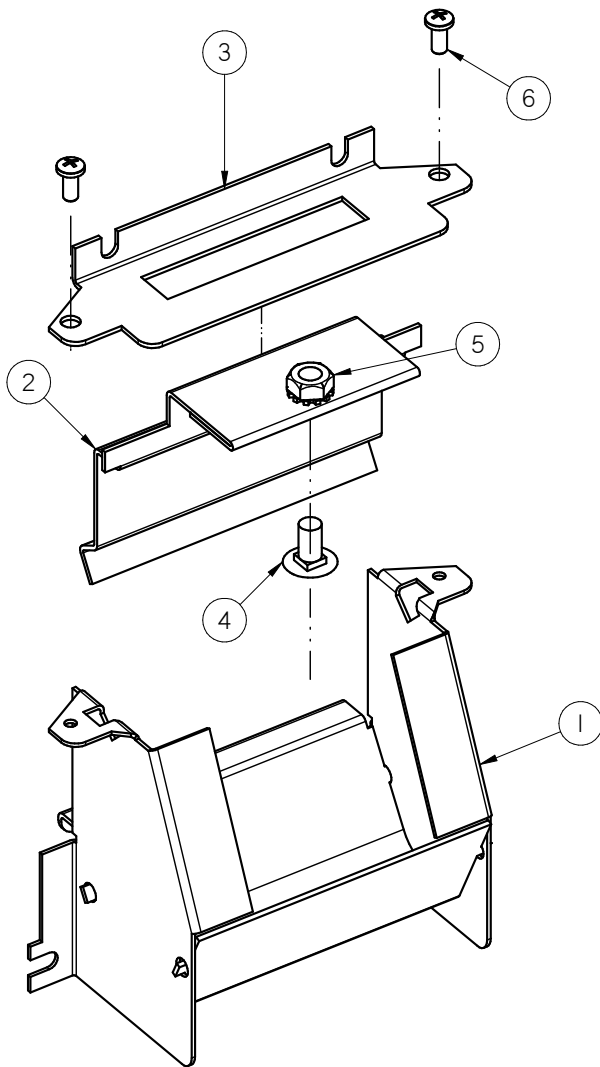

ITEM	DESCRIPTION	P/N
1	COIN CUP - WIDE W/A RVV700	408566
2	COIN CUP DOOR / WIDE - RVV700	408568
3	COIN CUP COVER / WIDE - RVV700	408569
4	1/4-20 X 1/2" CARRIAGE BOLT	901007
5	1/4-20 KEPS NUT	905002
6	SCREW, #8-32 X 3/8 PH PAN HD	901011

SECTION 6: Parts Catalog

Coin Return Lever Assembly 408556

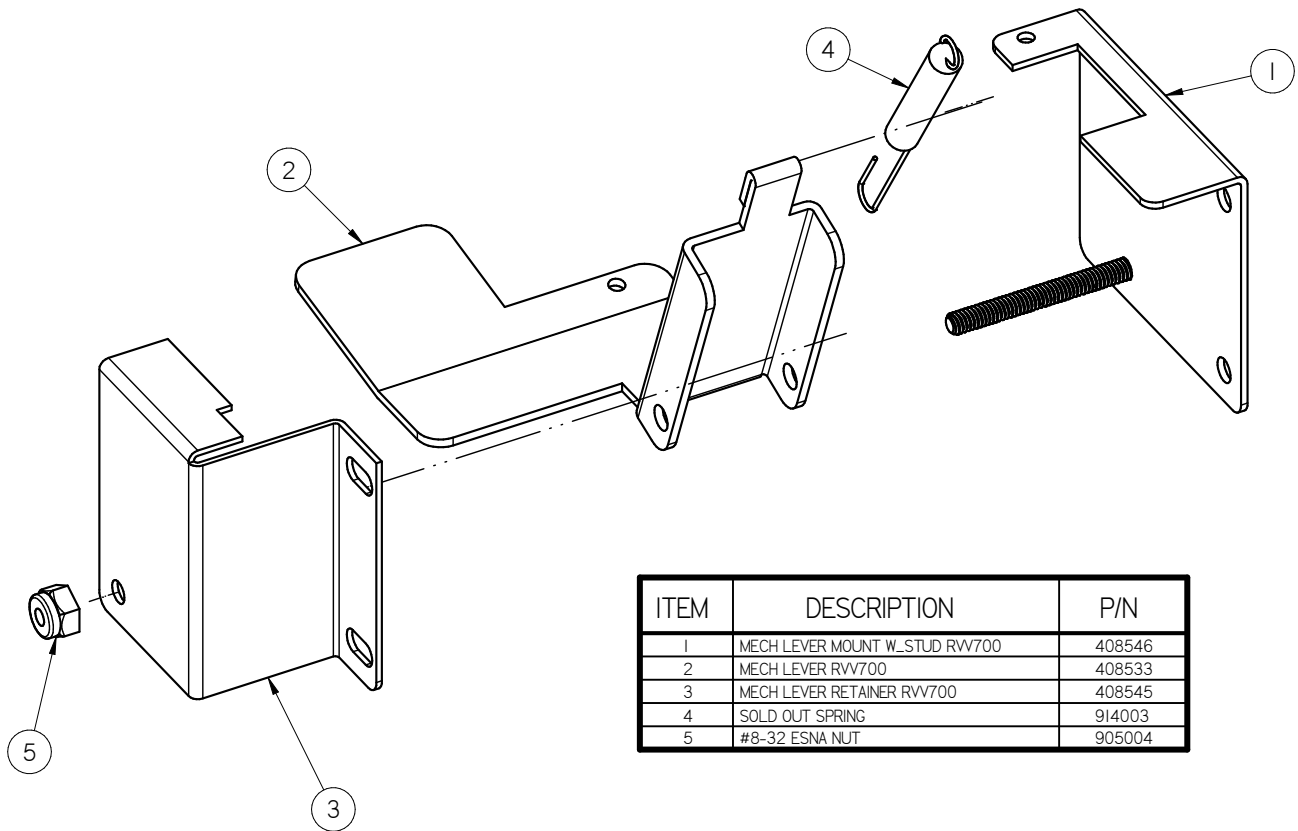

SECTION 6: Parts Catalog

Transaction Door Assembly

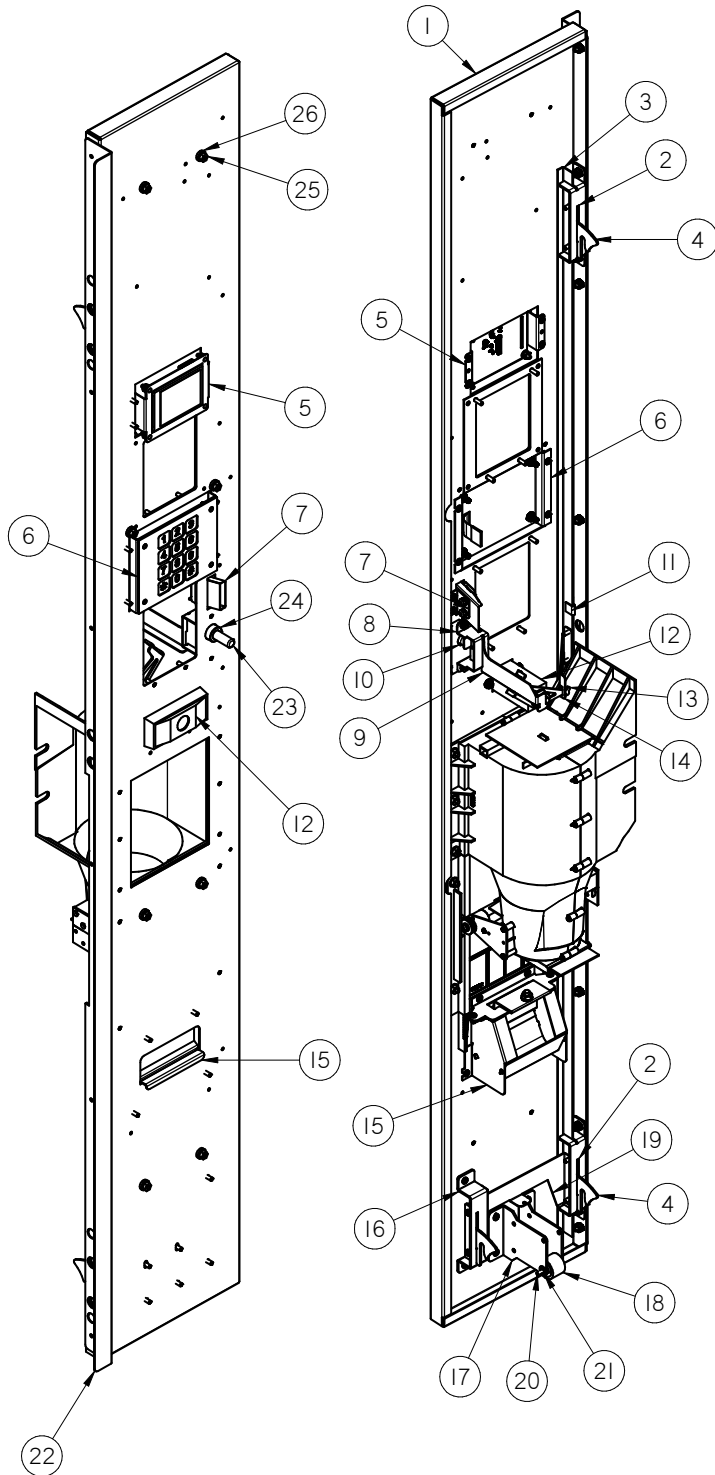

ITEM	DESCRIPTION	P/N
1	TRANSACTION DOOR W. STUDS - RVV700	408571
2	LATCH PLATE GUIDE RVV700	408536
3	DBL LATCH DRIVE ANGLE RVV700	408559
4	LATCH PLATE RVV700	408535
5	3.2" DISPLAY ASSY RVV700	408596
6	KEYPAD ASSY RVV700	408550
7	TRANS DOOR COIN CHUTE ASSY RVV700	408519
8	RETURN BUTTON RETAINER RVV700	408529
9	BUTTON LEVER RVV700	408531
10	BUSHING RETENTION PLATE	408530
11	BAR GUIDE RVV700	408537
12	T-HANDLE ASSEMBLY	812449
13	T-HANDLE LATCH DRIVE RVV700	408586
14	LATCH LIFT RVV700	408539
15	COIN CUP ASSY / WIDE - RVV700	408565
16	LATCH PLATE GUIDE - RIGHT RVV700	408580
17	DOOR ROLLER BRACKET RVV700	408562
18	DOOR ROLLER	815021
19	LATCH CONNECTOR RVV700	408581
20	COIN RETURN PIN	811024
21	RETAINER RING	906005
22	COMPRESSION ANGLE W. STUDS	408599
23	BUTTON COIN RETURN LEVER	803031
24	COIN RETURN BUSHING	803059
25	#8-32 SERRATED FLANGE NUT	905035
26	#10 ID X 1/2" OD X 3/32 THK. EPDM WASHER	904058

SECTION 6: Parts Catalog

Transaction Door Coin Chute Assembly 408519

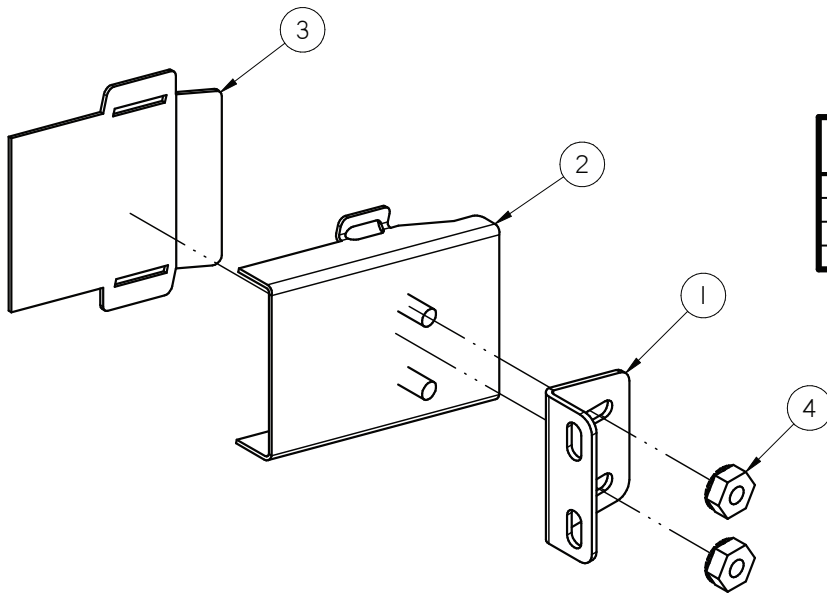

ITEM	DESCRIPTION	P/N
1	TRANS DOOR COIN CHUTE MNT.	408504
2	INSIDE TRANS CHUTE W/STUDS	408540
3	TRANS DOOR COIN CHUTE	408518
4	#6-32 KEPS NUT	905018

SECTION 6: Parts Catalog

RVV 700 Power Module Assembly 408023

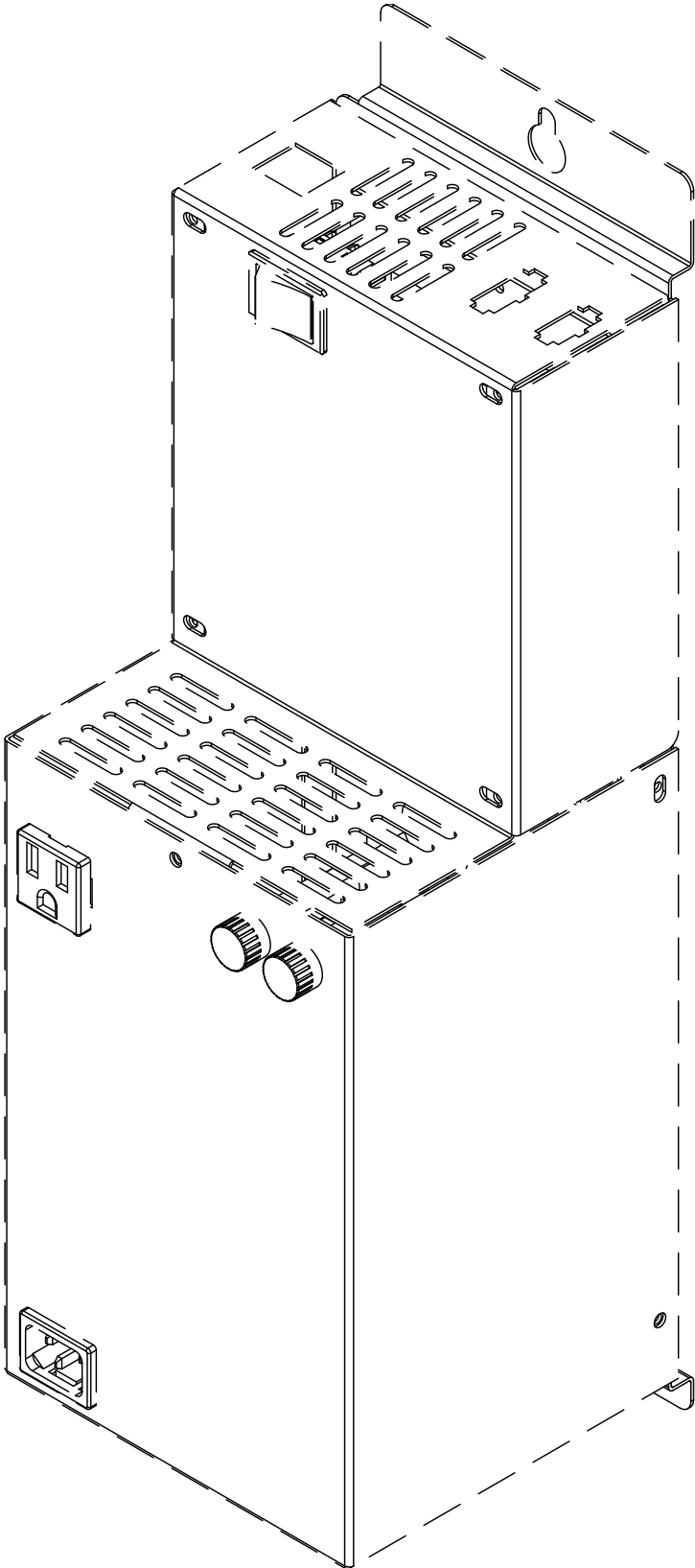

SECTION 6: Parts Catalog

RVV 700 Delivery Door Assembly 854077

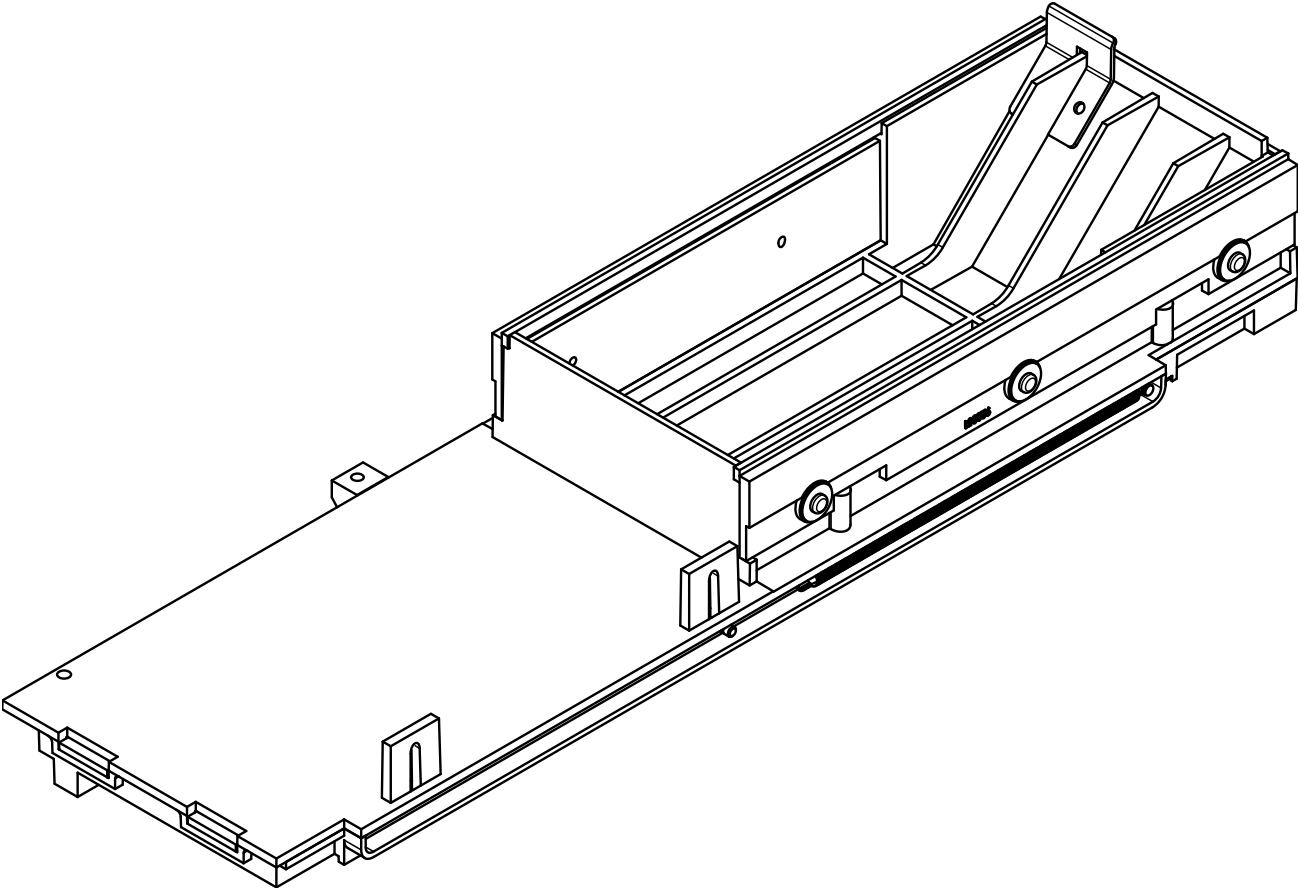

SECTION 6: Parts Catalog

RVV 700 Port Assembly 854078

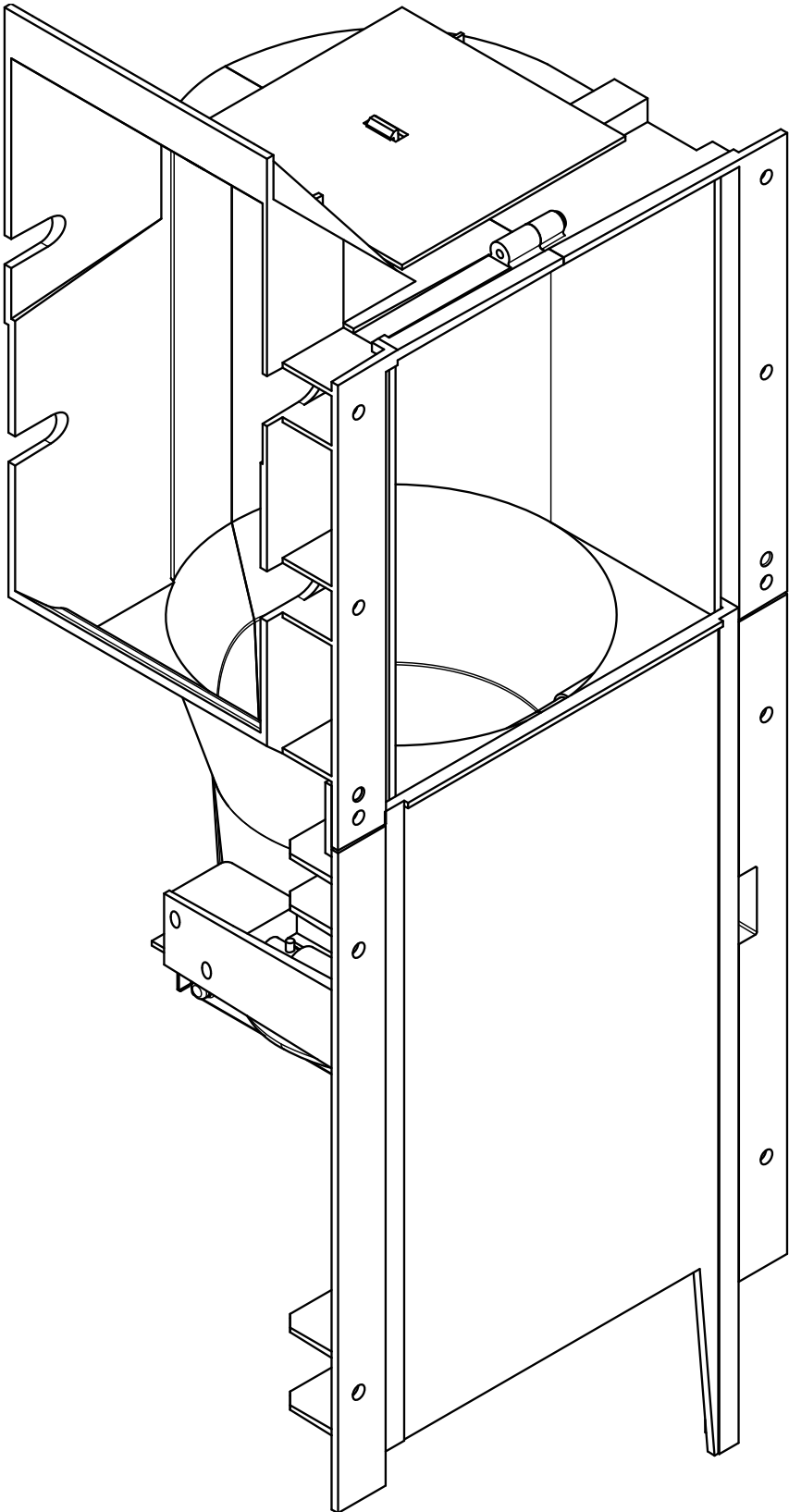

SECTION 6: Parts Catalog

RVV 700 Display Assembly 408596

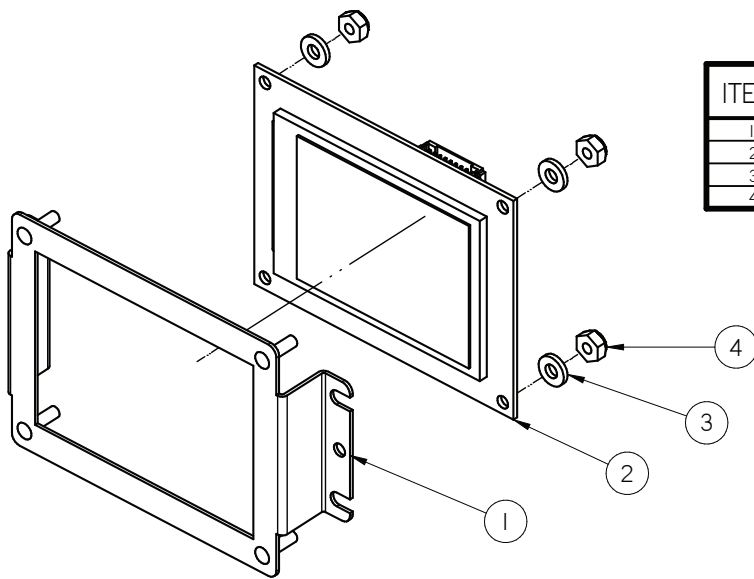

ITEM	DESCRIPTION	P/N
1	3.2" DISPLAY PLATE W_STUDS RVV700	408595
2	DISPLAY 3.5" RVV700	836331
3	WASHER, FLAT, NYLON, .173 I.D. X .375 O.D. X .062	904029
4	#6-32 ESNA NUT	905006

SECTION 6: Parts Catalog

RVV 700 Keypad Assembly 408550

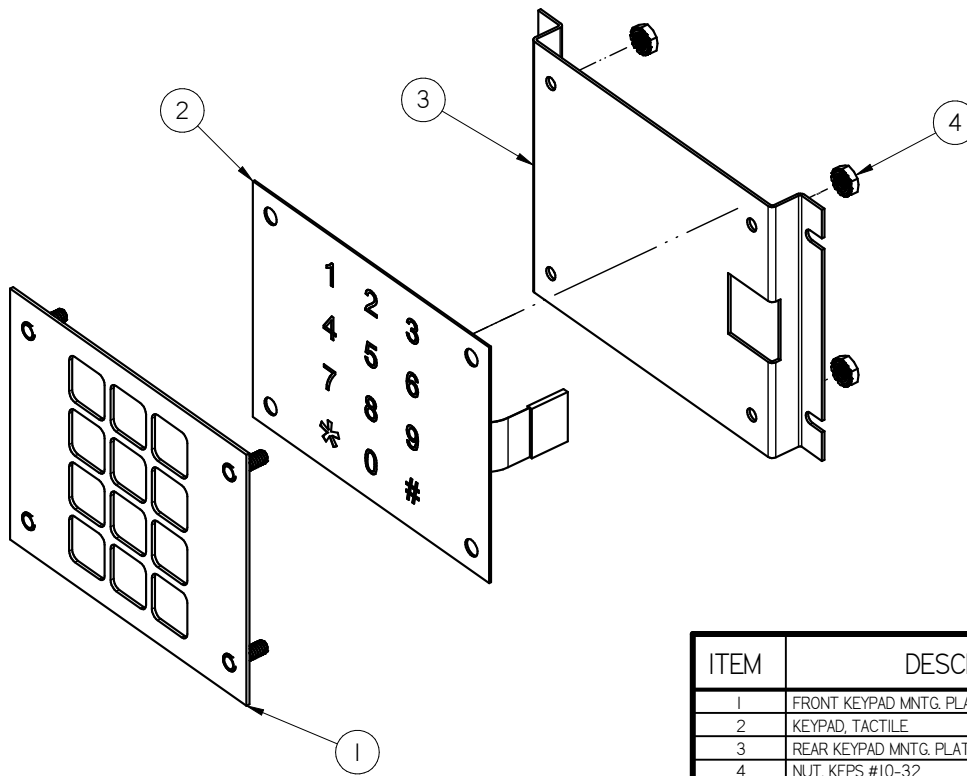

ITEM	DESCRIPTION	P/N
1	FRONT KEYPAD MNTG. PLATE W_STUDS RVV700	408549
2	KEYPAD, TACTILE	842997
3	REAR KEYPAD MNTG. PLATE RVV700	408547
4	NUT, KEPS #10-32	905009

SECTION 6: Parts Catalog

RVV 700 Shelf Assembly 854046

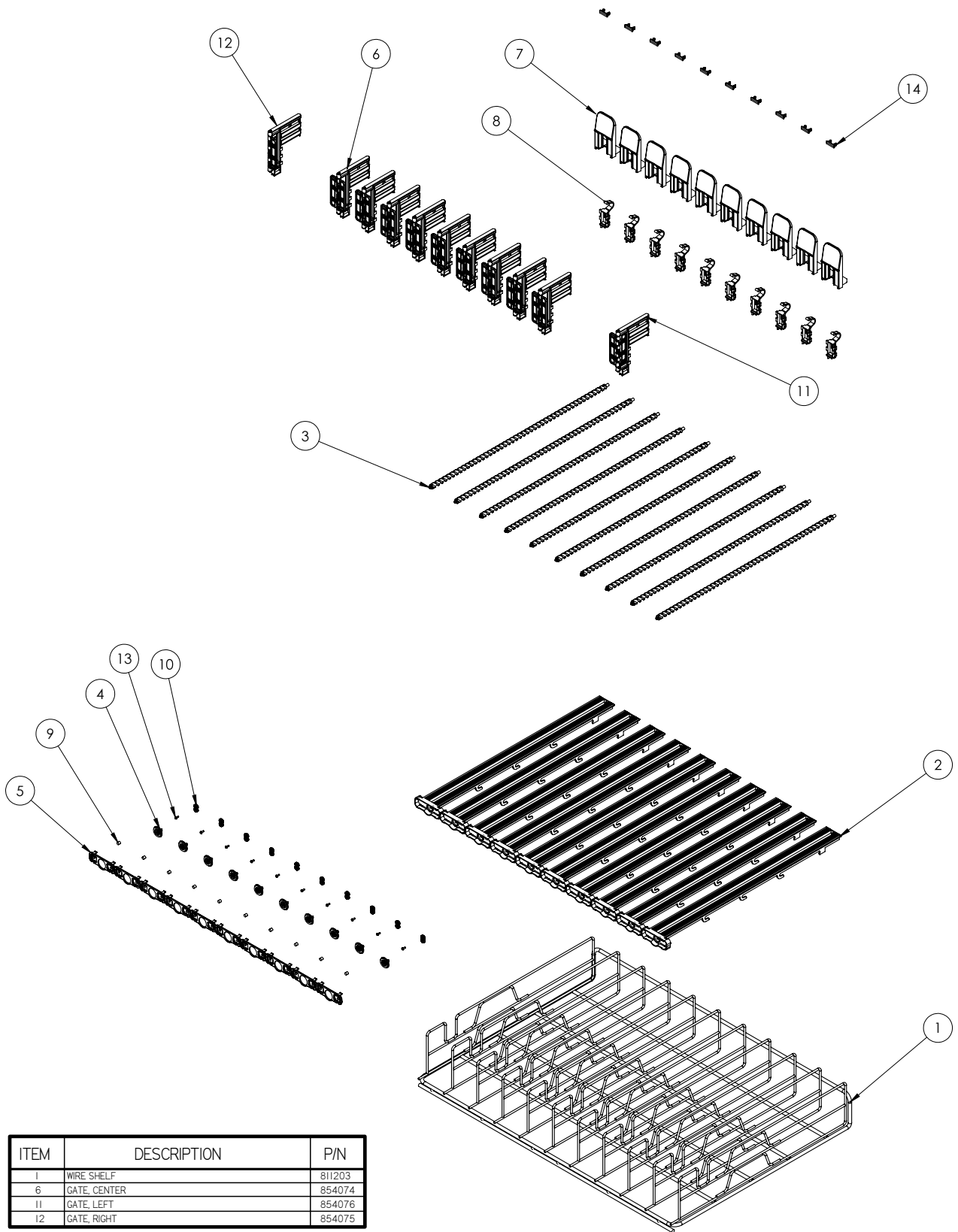

SECTION 6: Parts Catalog

RVV 700 Track Assembly 854097

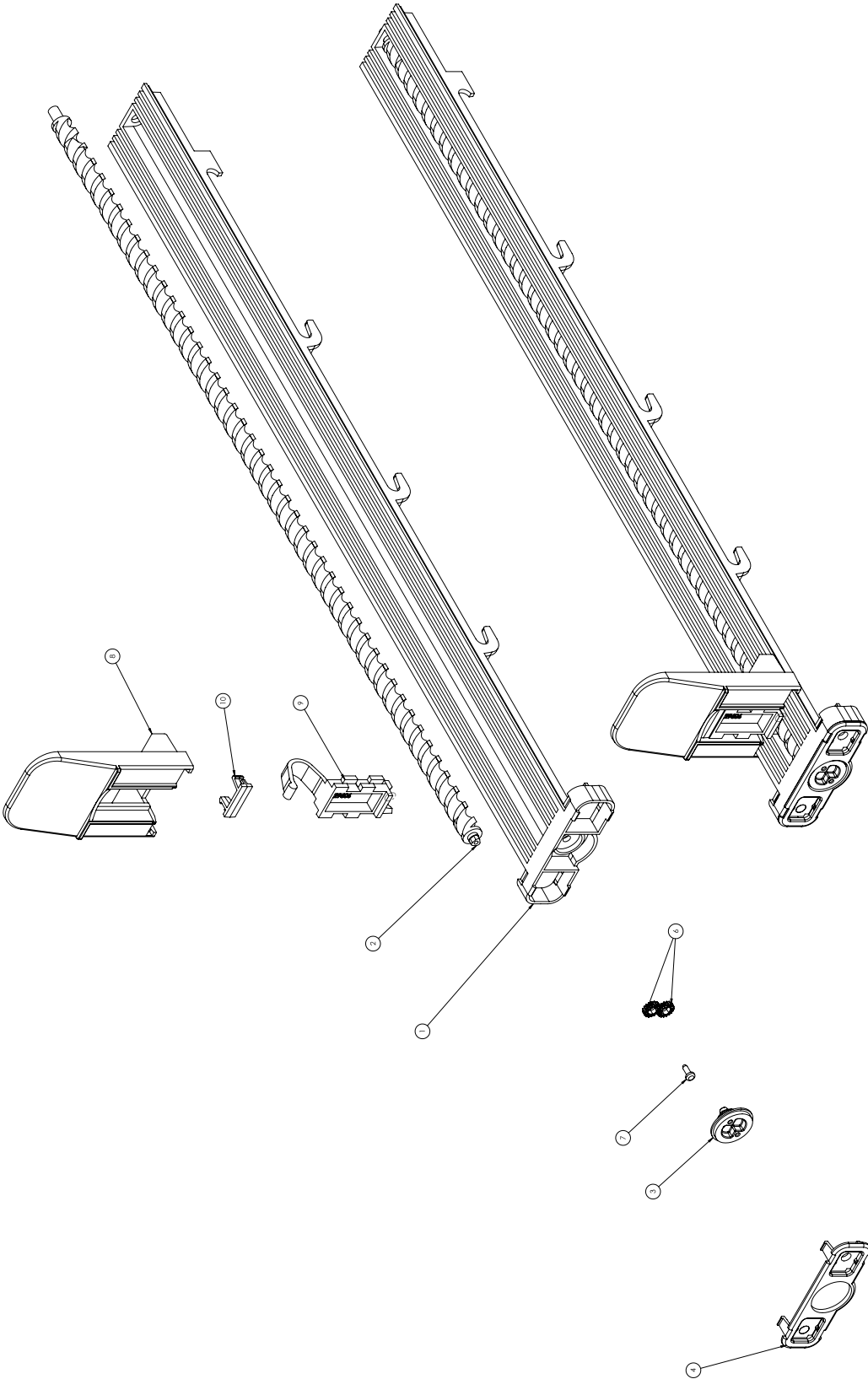

SECTION 6: Parts Catalog

**RVV 700 Refrigeration Assembly
408420**

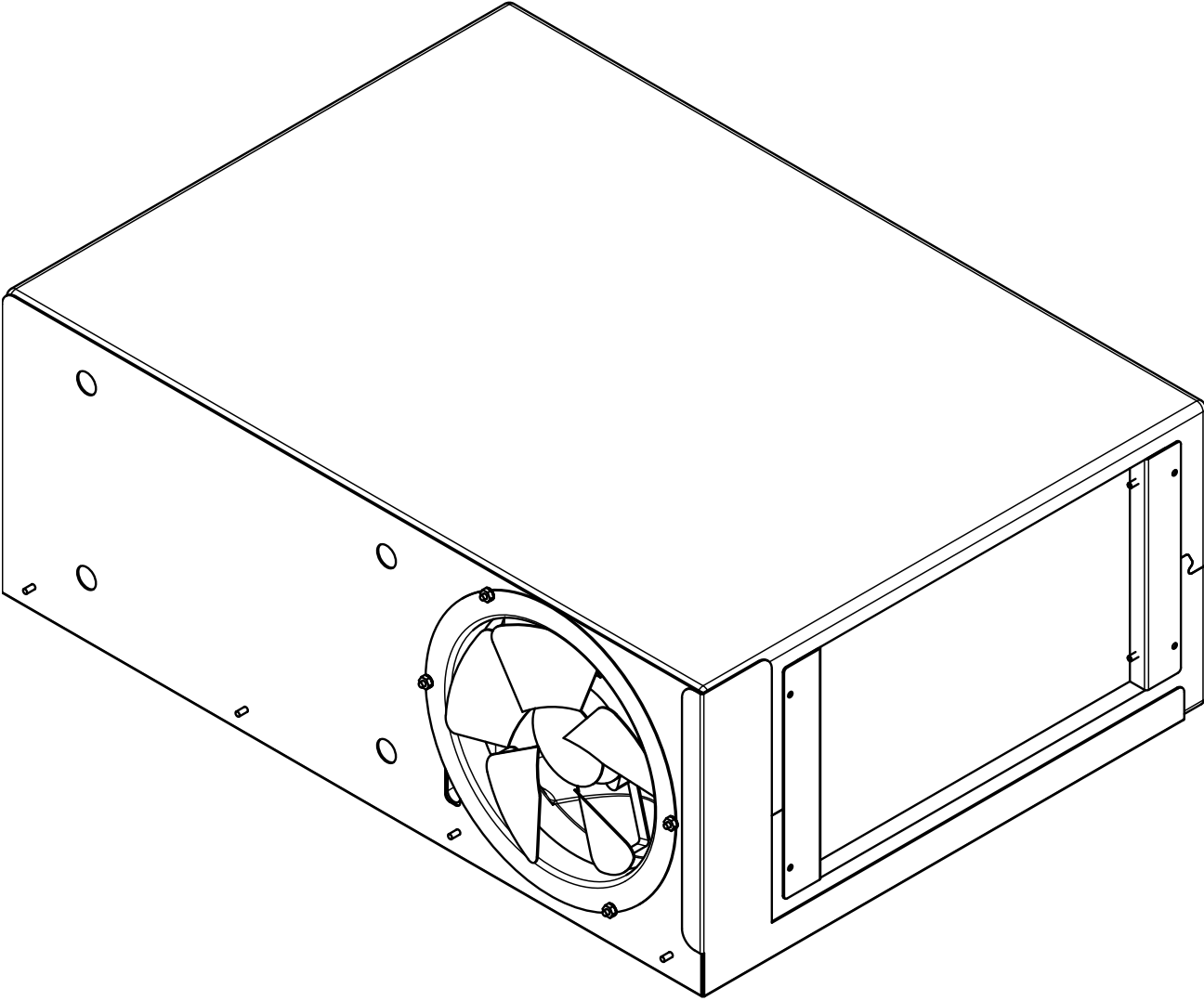

SECTION 6: Parts Catalog

Refrigeration Cover Assembly 408433

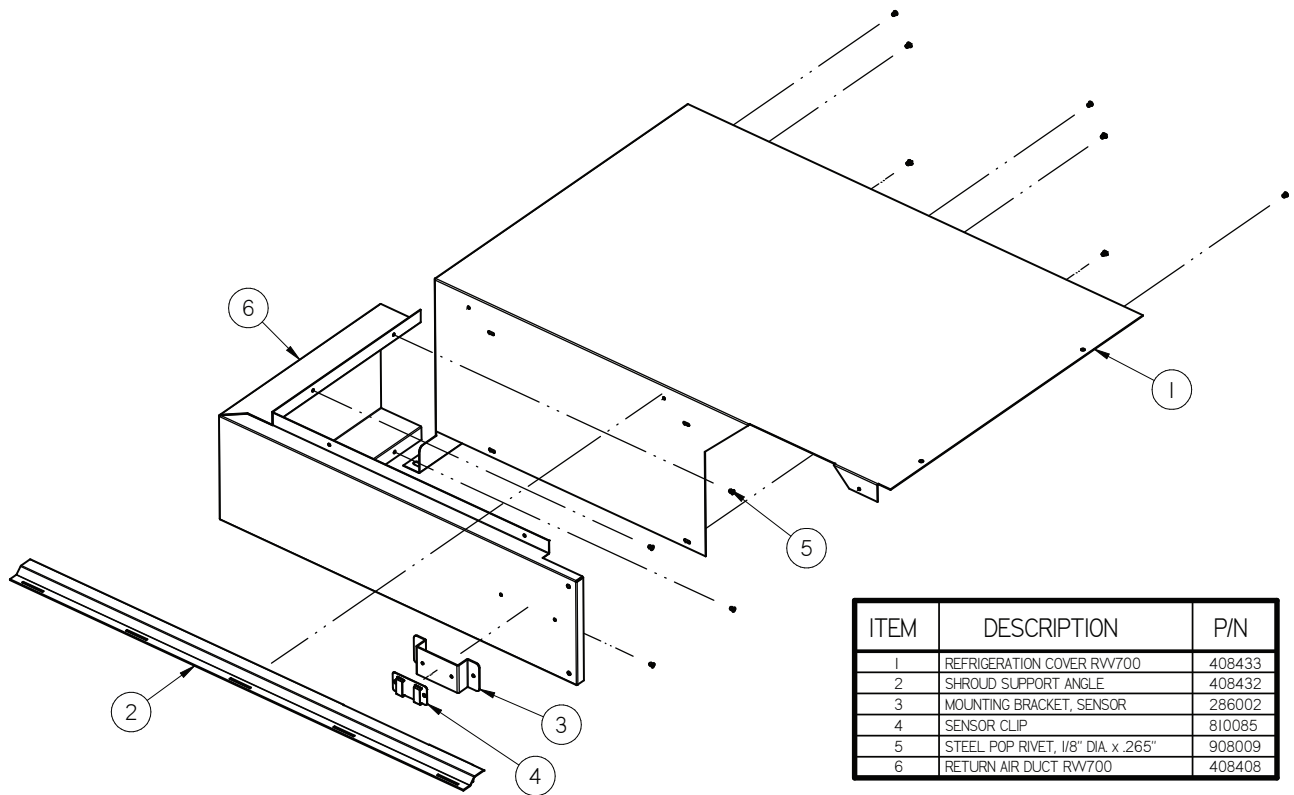

SECTION 6: Parts Catalog

Refrigeration Shroud Assembly 408431

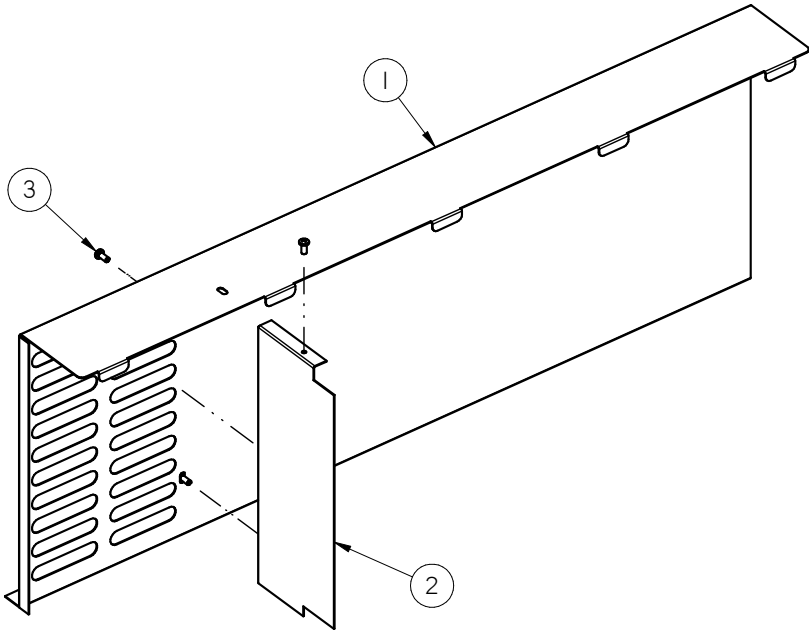

ITEM	DESCRIPTION	P/N
1	REFRIGERATION SHROUD	408429
2	SHROUD AIR BLOCK RV700	408435
3	SCREW, #8-32 X 3/8 PH PAN HD	901011

SECTION 6: Parts Catalog

Partition Panel Assembly 408433

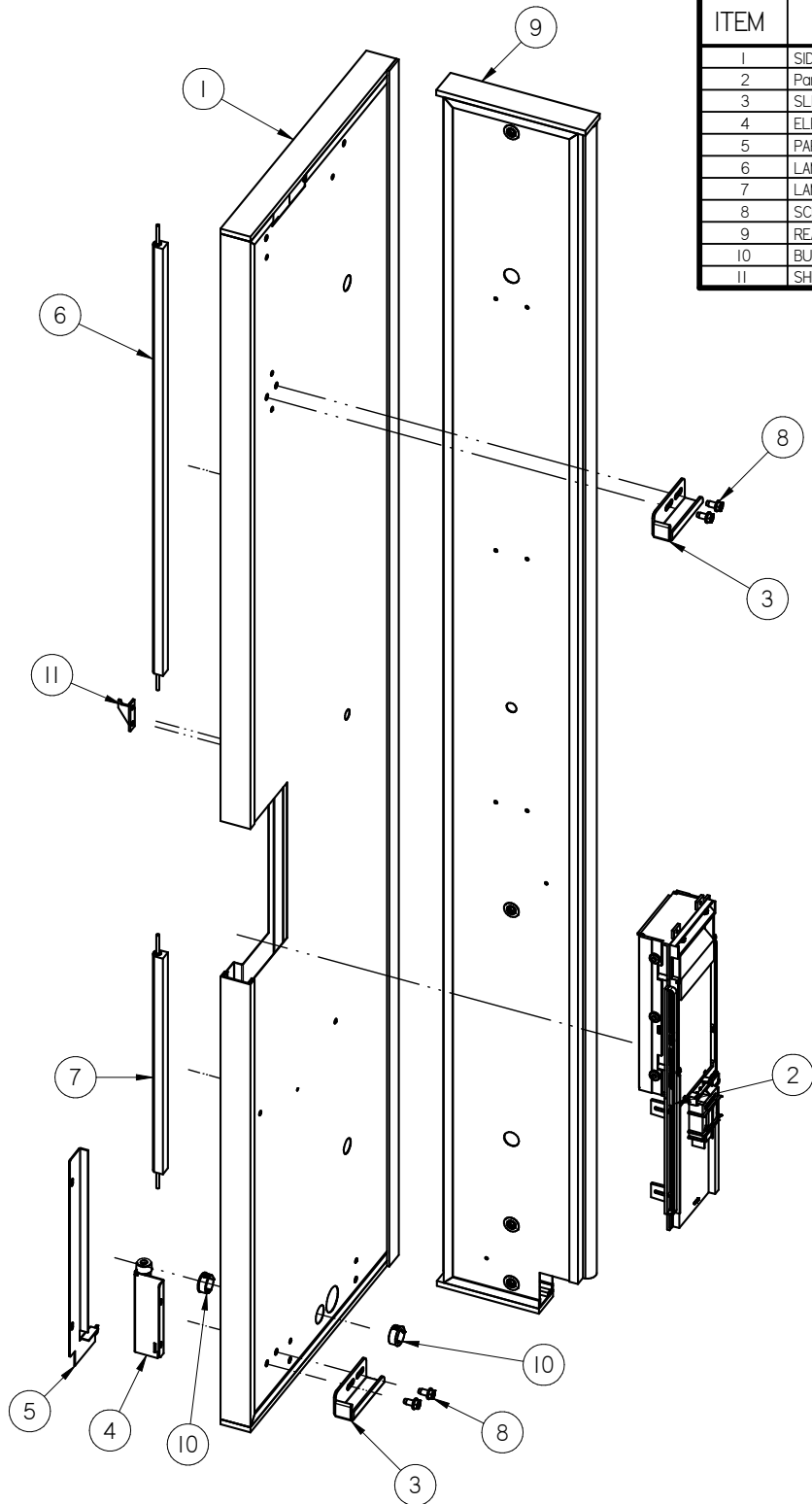

ITEM	DESCRIPTION	P/N
1	SIDE PARTITION PANEL ASSY - RVV700	408631
2	Part Name Required	Part Number
3	SLIDER LATCH LEFT W/A	408034
4	ELEVATOR BUMPER ASSY - RIGHT RVV 700	408807
5	PARTITION LAMP WIRE COVER RVV700	408025
6	LAMP, 24" "D" PROFILE FROSTED	841111
7	LAMP, 12" "D" PROFILE FROSTED	841112
8	SCREW, 1/4-20 X 1/2" HEX HEAD	901061
9	REAR PARTITION PANEL ASSY - RVV700	408619
10	BUSHING, OPEN/CLOSED 3/4" ID	916071
11	SHEET METAL CATCH RVV700	408812

Wiring Schematic

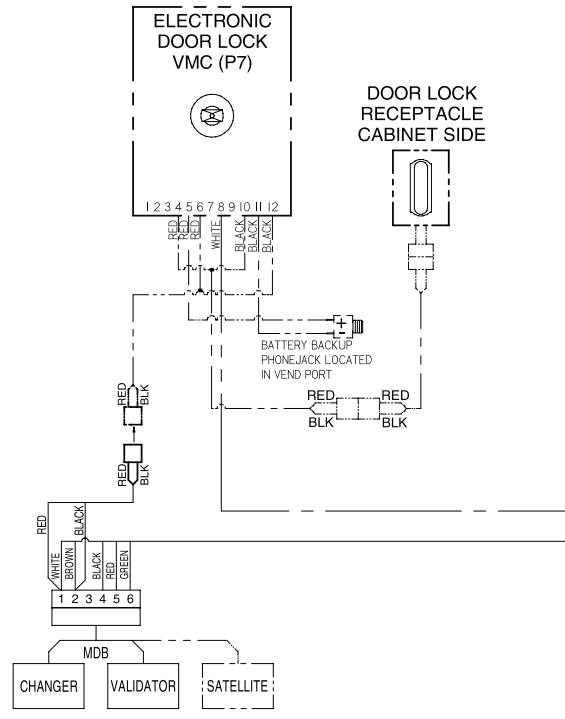
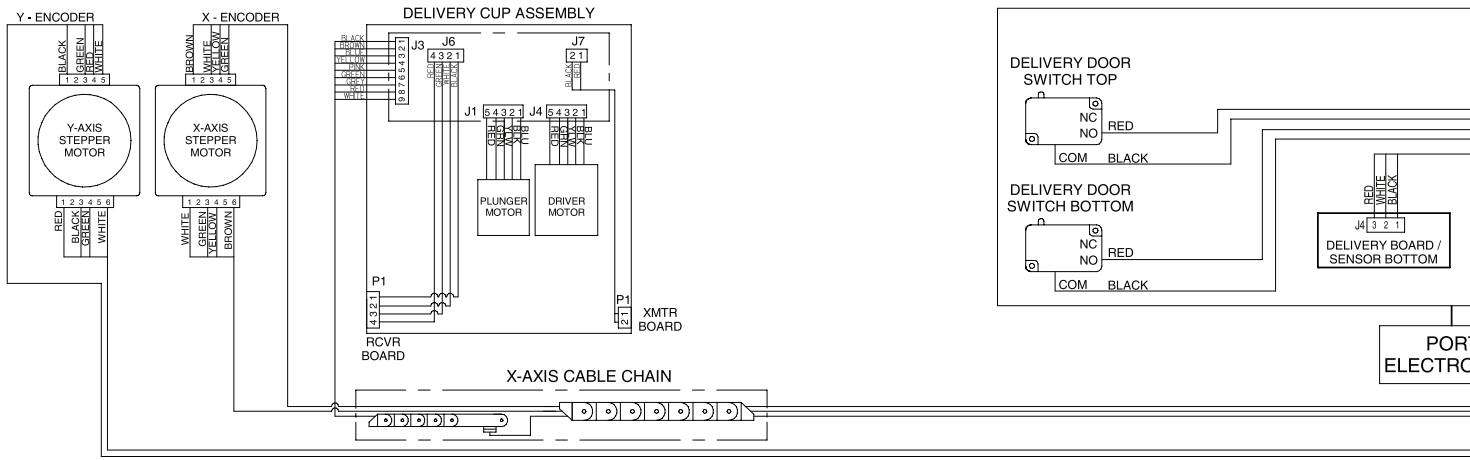

POSITION	VMC CONNECTION DESCRIPTION
P1	INT. / EXT. DEX / REMOTE MODE
P1A	DEX PHONE JACK
P2	SERIAL DISPLAY
P2A	SPI DISPLAY
P3	SELECTION KEYPAD
P4	SOLD OUT INDICATORS / KEYPAD
P5	POWER / 24 VOLTS DC
P6	REFRIG. / ENERGY MANAGEMENT
P6A	REFRIG. / ENERGY MANAGEMENT R290
P6C	CONSUMER PRESENCE
P7	DR. SWITCHES / ELEC. LOCK / OPTIONS
P8	TEMPERATURE / HEALTH SENSOR
P8D	DIGITAL TEMPERATURE
P9	MULTI-DROP BUS
P10C	DELIVERY CUP BOARD (J3)
P10P	DELIVERY BOARD / TOP SENSOR (J4)
P10X	X-MOTOR / X-ENCODER
P10Y	Y-MOTOR / Y-ENCODER
J1	CARD READER # 1
J2	CARD READER # 2
J3	CASHLESS / TELEMETRY COMM.
SW1	CONTROLLER MODE BUTTON

POSITION	PORT CONNECTION DESCRIPTION
J2	GUILLOTINE DOOR MOTOR
J3	PORT DOOR MOTOR
J4	VMC-P10P
J6	PORT DOOR SOLENOID, DELIVERY DOOR SWITCH TOP / DELIVERY DOOR SWITCH BOTTOM
J14	DELIVERY BOARD / BOTTOM SENSOR

POSITION	DELIVERY CUP ASSY DESCRIPTION
J1	PLUNGER MOTOR
J3	X-AXIS (VMC-P10C)
J4	DRIVER MOTOR
J6	RCVR BOARD
J7	XMTR BOARD

Wiring Schematic

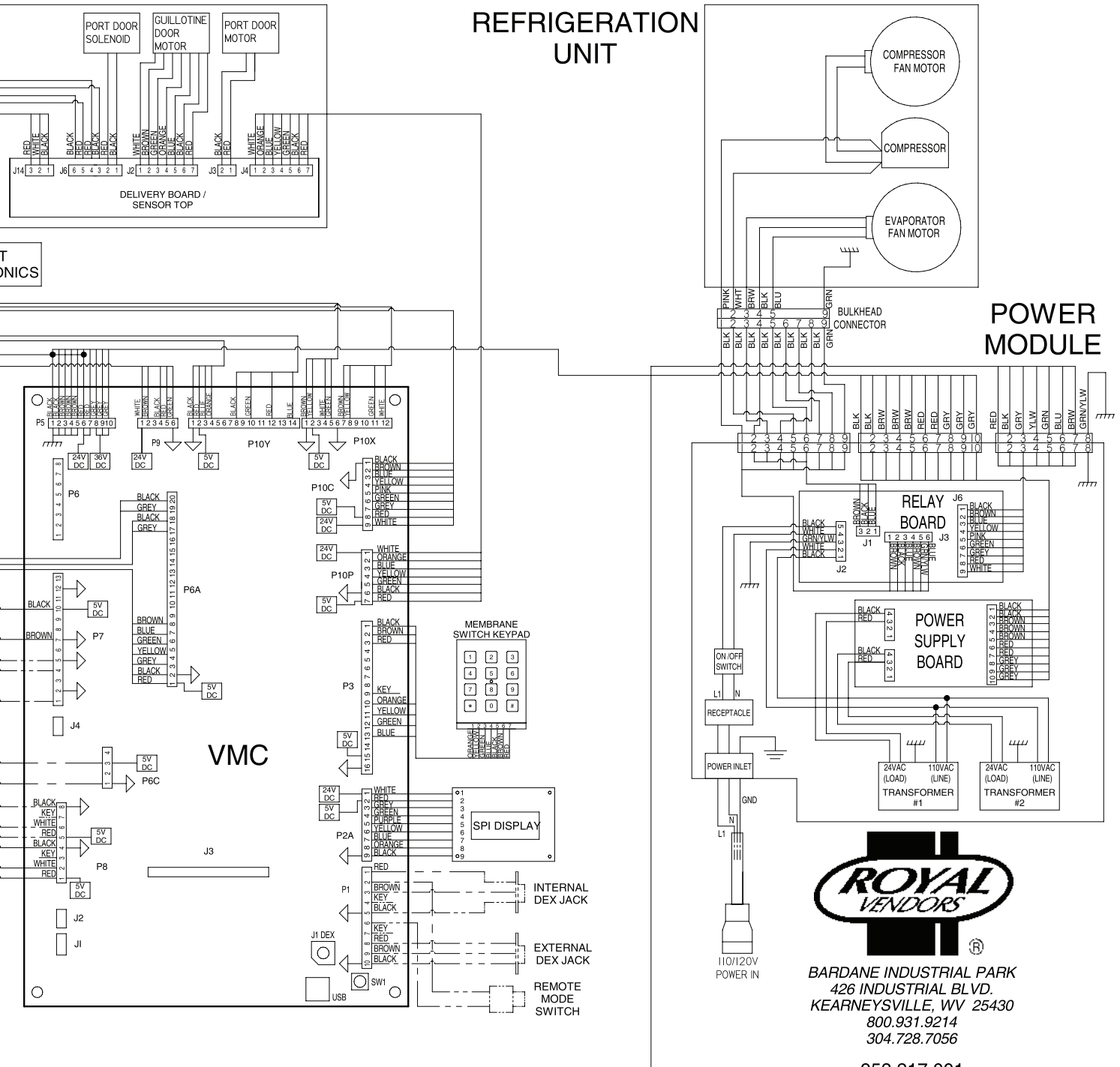

BARDANE INDUSTRIAL PARK
 426 INDUSTRIAL BLVD.
 KEARNEYSVILLE, WV 25430
 800.931.9214
 304.728.7056

953,217,001
 RVV 700 WIRING DIAGRAM

CREDIT AND REPLACEMENT POLICY

Credits or replacements will be issued on warranty items if the proper procedures are followed:

1. ROYAL VENDORS will pay shipping charges on all parts covered under this warranty when transportation has been made the most economical way. (Example: Within the continental USA, regular ground UPS). An A.R.S. (Authorized Return Service) sticker will be sent with all warranty parts. This method of shipping is preferred for returning parts to Royal.
2. Credits will only be issued to warranty parts that have been ordered in advance, not for parts ordered as stock. (NO EXCEPTIONS)
3. When ordering warranty parts in advance, please have the full vender, refrigeration unit, and / or control board serial numbers.
4. A copy of the Packing Slip, the correct serial number and complete Return Material Tag (provided with part) are required for returning parts. Please fill out the Return Material Tag completely, keeping the white copy for your records and returning the yellow tag with the attached part. Make sure to fill in the company name, address, telephone number, serial number, and model number, along with a brief explanation of the problem.
5. If the item returned is not under warranty, it will be returned at your expense along with a US\$10.00 handling fee or it will be scrapped.
6. All warranty parts should be properly wrapped and packed securely to avoid further damage. Parts that are returned from the field and have been tapped into, tampered with, not packaged properly, or have had the serial plate or label removed, will void the warranty.
7. If parts are not returned within 15 working days, the invoice will be due in full.



Royal Vendors' Publication
833128 Rev. 01
April 2019



Printed in the United States of America