

2/10/96

1. PRODUCT

12 OZ. CANS - 2.60 x 4.84 Long

2. PRODUCT CAPACITY

48 PER COLUMN - 72", 57 PER COLUMN - 79"

3. SET UP GUIDE UNIVENDOR-2

Product	CAM POSITION	BACK SPACER	GAGE BAR	Sold out Lever	SIDE SPACER	GAGE BAR CLIP	
						Part No.	Position
12 oz CANS	3	8	2	389242 SHORT	1060686	1066104 White	1 & 2

Note: To properly vend 12 oz. Cans. The Univendor-2 must have the columns setup correctly.

4. GAGE BAR CLIP SET UP.

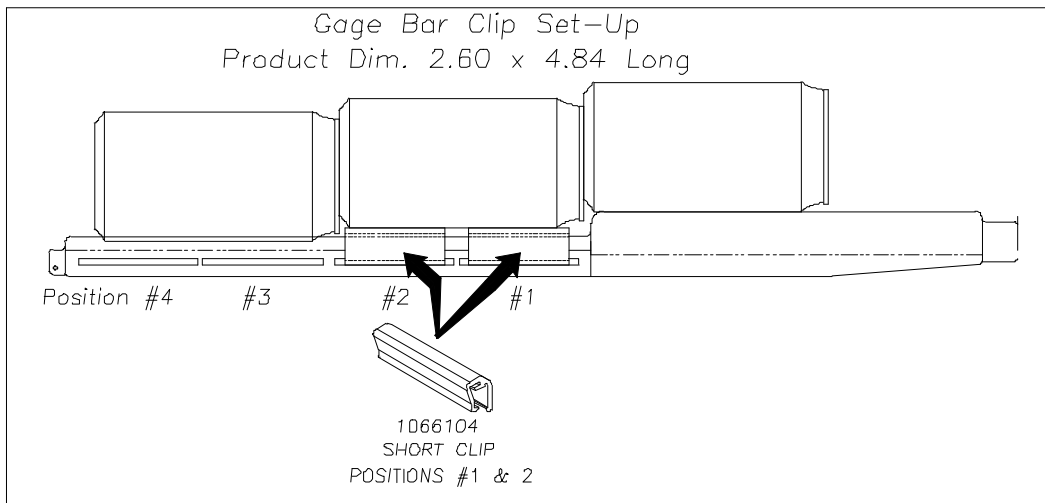

5. SET UP GUIDE.

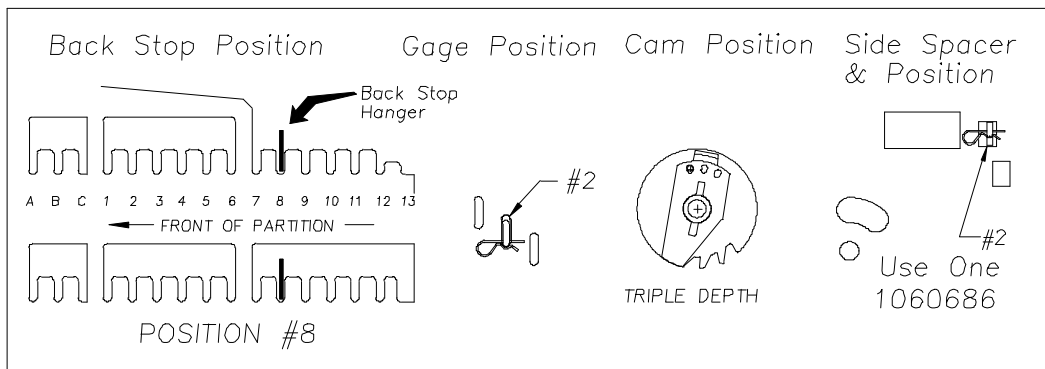

6. SOLD-OUT LEVER TO BE SHORT STYLE WITH FRONT SPACER. SPRING TO BE LOCATED ON THE RIGHT SIDE (LOW PRESSURE SETTING).

Vendo[®] Engineering Uni-2 Set Up Guide

Size: 16oz / 473ml

Rev. B Date 5/31/00

Pkg. Description/Type: TROPICANA PET

Franchise: PEPSI

KIT#

Column Setup

Cam Setting	Back Spacer	Neck Guide Locations	Gage Bar Clip Location	Gage Bar Location	Side Spacer	Sold Out Flap	Sold Out Spacer
2	9	N/A	C/#1	#2	1060686 Loc. #2	Short* 1083449	1077457

Note: To properly vend product the Uni-2 must have the columns set up as illustrated. *Spring Loc. Rt (Low Tension) side.

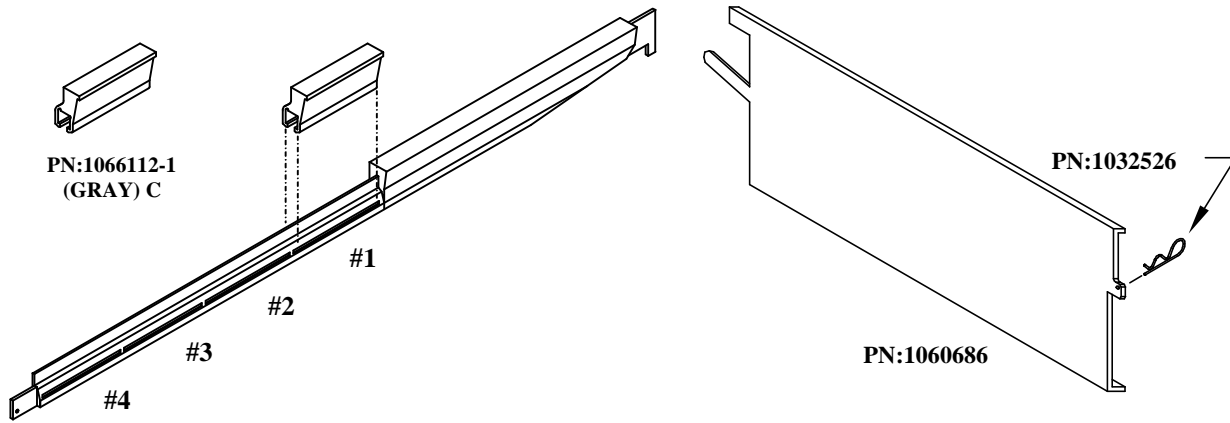

Gage Bar Clip Location

Shim/Spacer

Set Up Guide

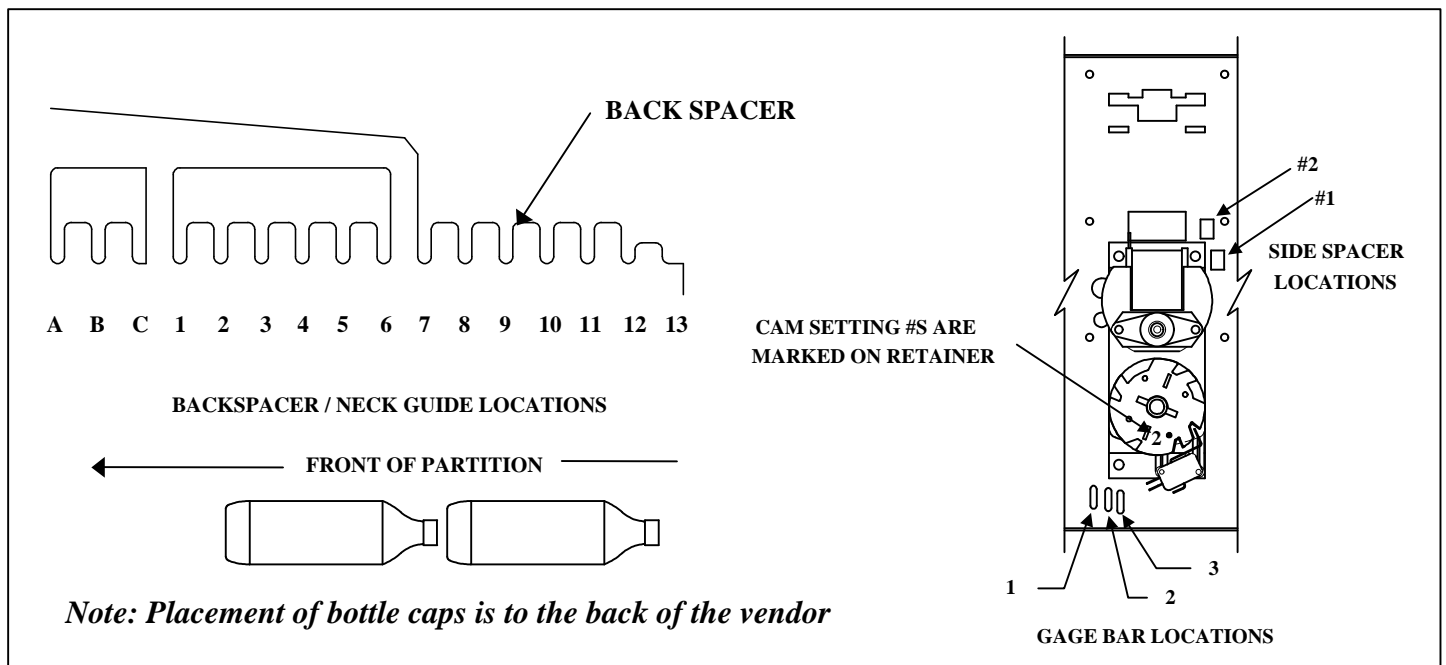

FOR OTHER PRODUCT SET-UP GUIDES, CONTACT THE VENDO COMPANY
 TEL: (559) 439-1770 FAX: (559) 650-3455.

Installation Instruction #

1. PRODUCT

16 OZ. ALL SPORT PET BOTTLE - 2.82 Top x 7.14 Long

2. PRODUCT CAPACITY

28 PER COLUMN - 72", 34 PER COLUMN - 79"

3. SET UP GUIDE UNIVENDOR-2

Product	CAM POSITION	BACK SPACER	GAGE BAR	Sold out Lever	SIDE SHIM	GAGE BAR CLIP	
						Part No.	Position
16 oz All Sport	2	8	1	389242 SHORT	TWO 1066821	1066112-1	1

Note: To properly vend 16 oz. All Sport. The Univendor-2 must have the columns setup correctly.

4. GAGE BAR CLIP SET UP.

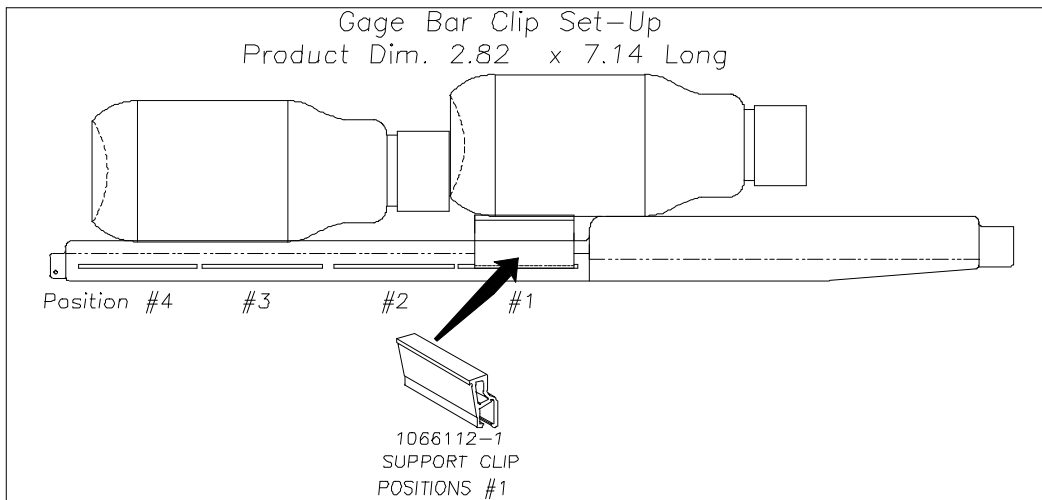

5. SET UP GUIDE.

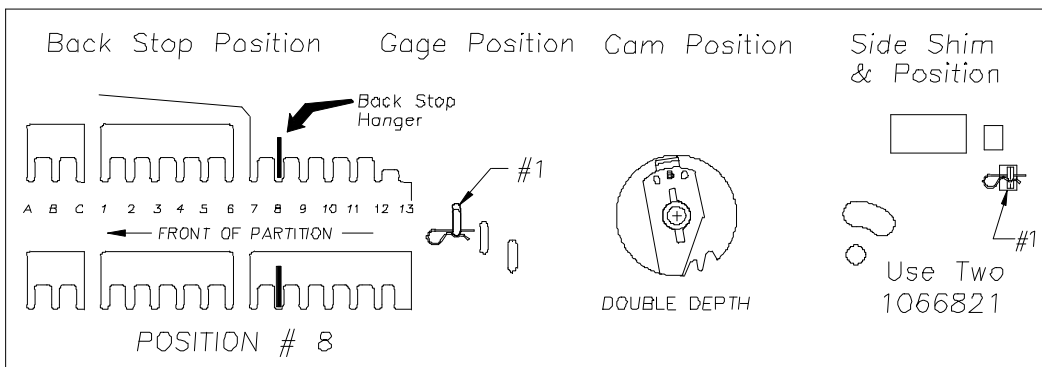

6. SOLD-OUT LEVER TO BE SHORT STYLE WITH FRONT SPACER. SPRING TO BE LOCATED ON THE RIGHT SIDE (LOW PRESSURE SETTING).

Vendo[®] Engineering Uni-2 Set Up Guide

Size: 16oz / 473ml
4/17/2000

Rev. A Date

Pkg. Description/Type: PEPSI - LIPTON'S ICED TEA GLASS (ROCKET BOTTLE)

Franchise: PEPSI

KIT#

Column Setup

Cam Setting	Back Spacer	Neck Guide Locations	Gage Bar Clip Location	Gage Bar Location	Side Spacer	Sold Out Flap	Sold Out Spacer
2	9	N/A	C/#1	Front #1 Rear #2	2-1074465 Loc. #1	Short 1083449	1077457

Note: To properly vend product the Uni-2 must have the columns set up as illustrated.

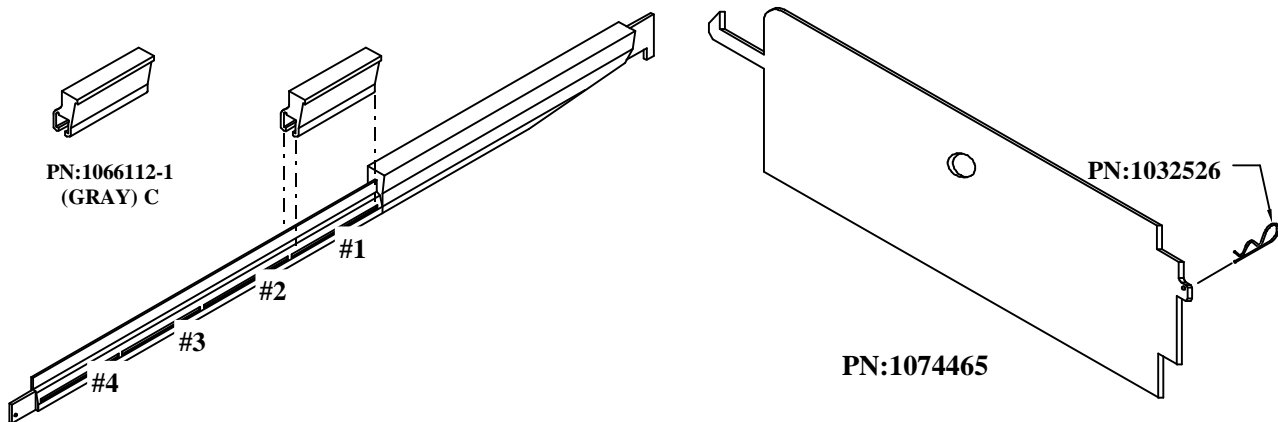

Gage Bar Clip Location

Shim/Spacer

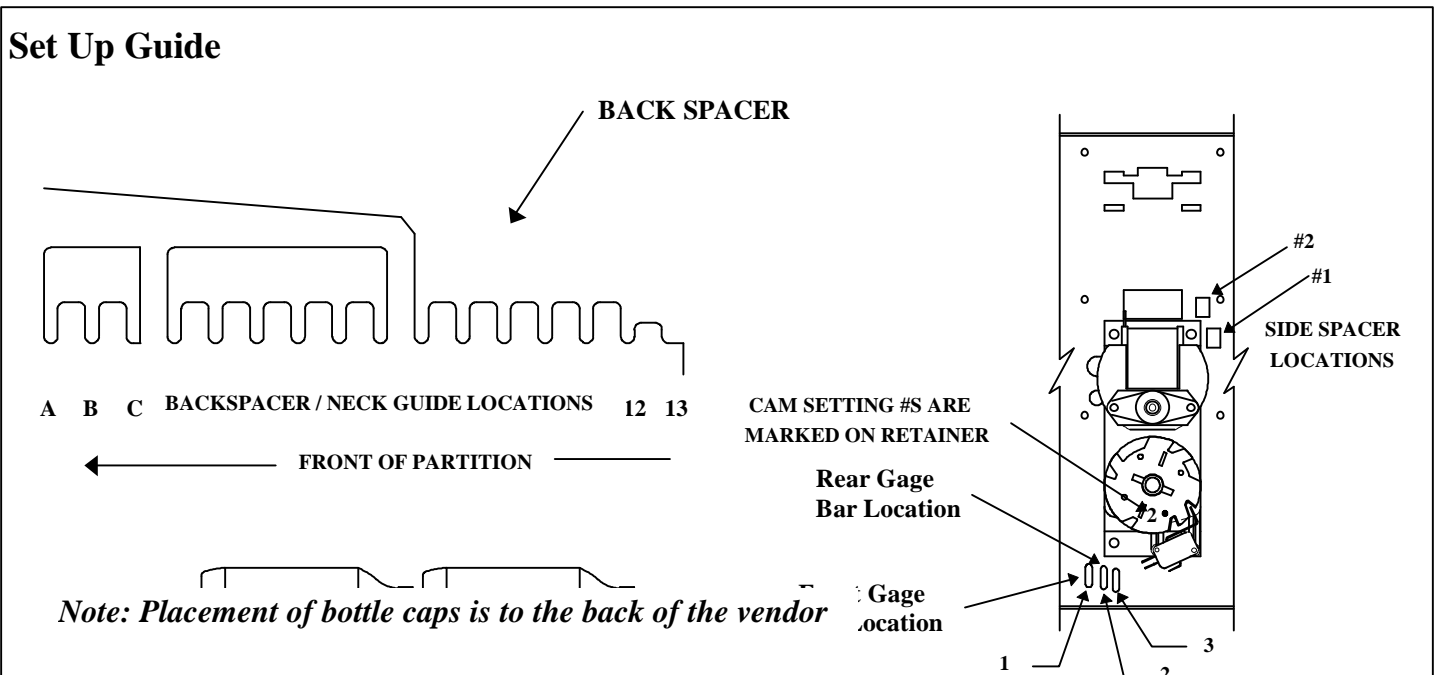

GAGE BAR LOCATIONS

Installation Instruction

**FOR OTHER PRODUCT SET-UP GUIDES, CONTACT THE VENDO COMPANY.
TEL: (559) 439-1770 FAX: (559) 439-2083.**

Vendo[®] Engineering Uni-2 Set Up Guide

Size: 16oz / 473ml
4/17/2000

Rev. A Date

Pkg. Description/Type: OCEAN SPRAY PET

Franchise: OCEAN SPRAY

KIT#

Column Setup

Cam Setting	Back Spacer	Neck Guide Locations	Gage Bar Clip Location	Gage Bar Location	Side Spacer	Sold Out Flap	Sold Out Spacer
2	7	N/A	C/#1	#1	2-1074465 Loc. #1	Short 1083449	1077457

Note: To properly vend product the Uni-2 must have the columns set up as illustrated.

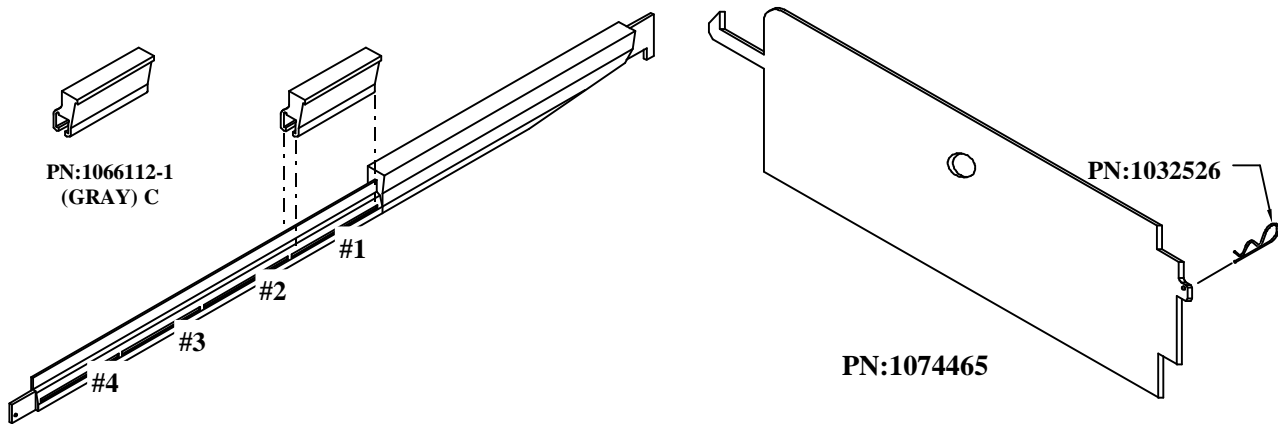

Gage Bar Clip Location

Shim/Spacer

Set Up Guide

BACK SPACER

A B C BACKSPACER / NECK GUIDE LOCATIONS 12 13

← FRONT OF PARTITION →

Note: Placement of bottle caps is to the back of the vendor

CAM SETTING #S ARE MARKED ON RETAINER

SIDE SPACER LOCATIONS

1 2 3

GAGE BAR LOCATIONS

**FOR OTHER PRODUCT SET-UP GUIDES, CONTACT THE VENDO COMPANY.
TEL: (559) 439-1770 FAX: (559) 439-2083.**

1. PRODUCT

20 OZ. PEPSI PET 18 SWIRL TOP - 2.86 Top x 2.86 Btm x 8.61 Long

2. PRODUCT CAPACITY

28 PER COLUMN - 72", 34 PER COLUMN - 79"

3. SET UP GUIDE UNIVENDOR-2

Product	CAM POSITION	BACK SPACER	GAGE BAR	Sold out Lever	SIDE	GAGE BAR CLIP	
					SHIM	Part No.	Position
20 oz PEPSI	2	13	1	389242 SHORT	**TWO 1066821	1066112	1

Note: To properly vend 20 oz. Pepsi. The Univendor-2 must have the columns setup correctly.
** two flat shims are optional for the 18 swirl, will not effect the product from vending.

4. GAGE BAR CLIP SET UP.

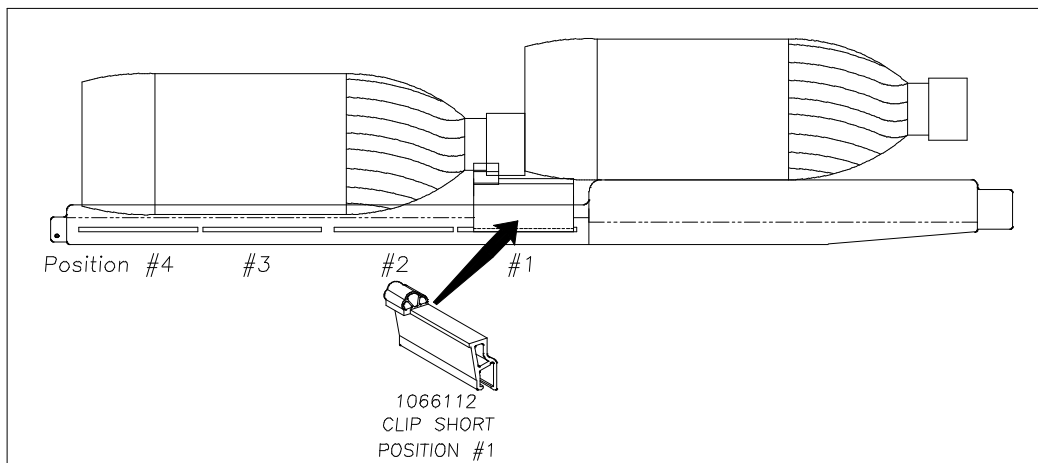

5. SET UP GUIDE.

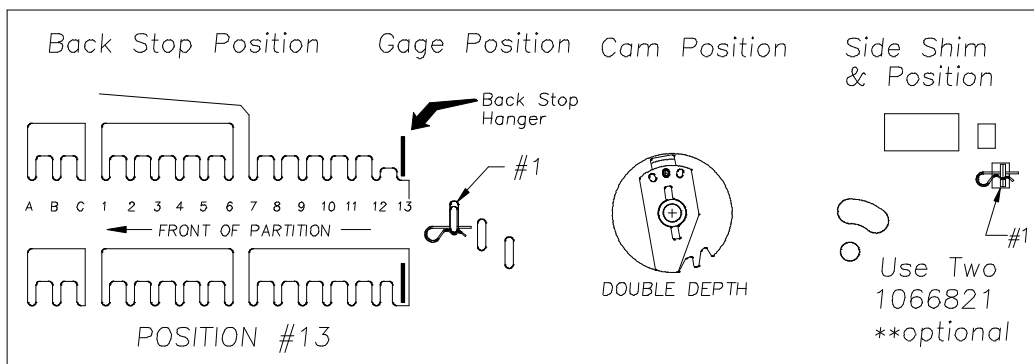

6. SOLD-OUT LEVER TO BE SHORT STYLE WITH NEW FRONT SPACER #1077457. SPRING TO BE LOCATED ON THE RIGHT SIDE (LOW PRESSURE SETTING).

**7. FOR OTHER PRODUCT SET UP GUIDES CONTACT VENDO COMPANY.
TEL: (209) 439-1770 FAX: (209) 439-2083.**

1. PRODUCT

20 OZ. ALL SPORT PET BOTTLE - 2.90 Top x 8.12 Long

2. PRODUCT CAPACITY

28 PER COLUMN - 72", 32 PER COLUMN - 79"

3. SET UP GUIDE UNIVENDOR-2

Product	CAM POSITION	BACK SPACER	GAGE BAR	Sold out Lever	SIDE SHIM	GAGE BAR CLIP	
						Part No.	Position
20 oz All Sport	2	11	1	389242 SHORT	NONE	1066112	1

Note: To properly vend 20 oz. All Sport. The Univendor-2 must have the columns setup correctly.

4. GAGE BAR CLIP SET UP.

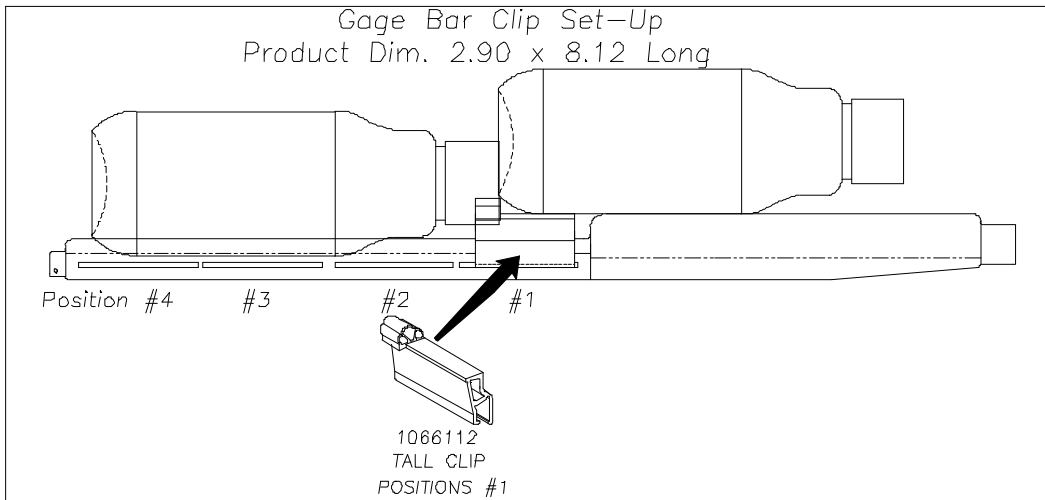

5. SET UP GUIDE.

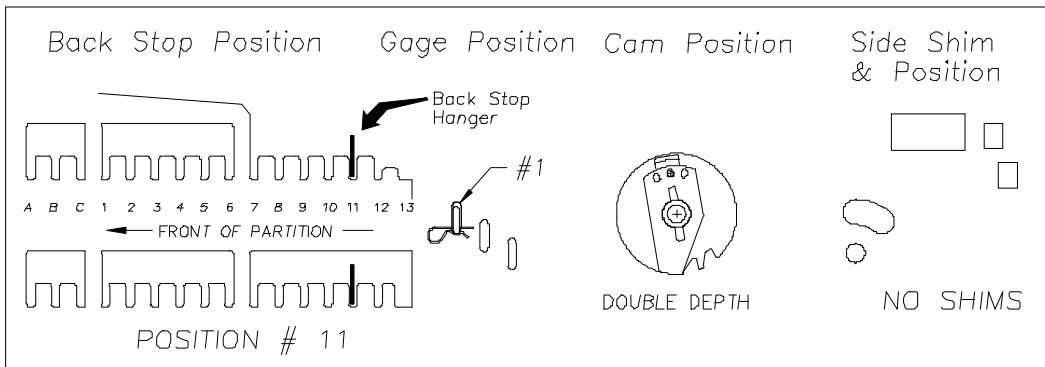

**6. SOLD-OUT LEVER TO BE SHORT STYLE WITH FRONT SPACER.
SPRING TO BE LOCATED ON THE RIGHT SIDE (LOW PRESSURE SETTING).**

AQUAFINA 20 OZ. P.E.T. SWIRL BOTTLE



UNIVENDOR-2 PRODUCT SET-UP GUIDE

2/16/96

REV. 1/23/97

1. PRODUCT

2.83 Top x 2.84 Btm x 8.59 Long

2. PRODUCT CAPACITY

28 PER COLUMN - 72", 34 PER COLUMN - 79"

3. SET UP GUIDE

CAM POSITION	BACK SPACER	GAGE BAR	Sold out Lever	SIDE SHIM	GAGE BAR CLIP	
					Part No.	Position
2	12	1	389242 SHORT	TWO 1066821	1066112	1

4. GAGE BAR CLIP SET UP.

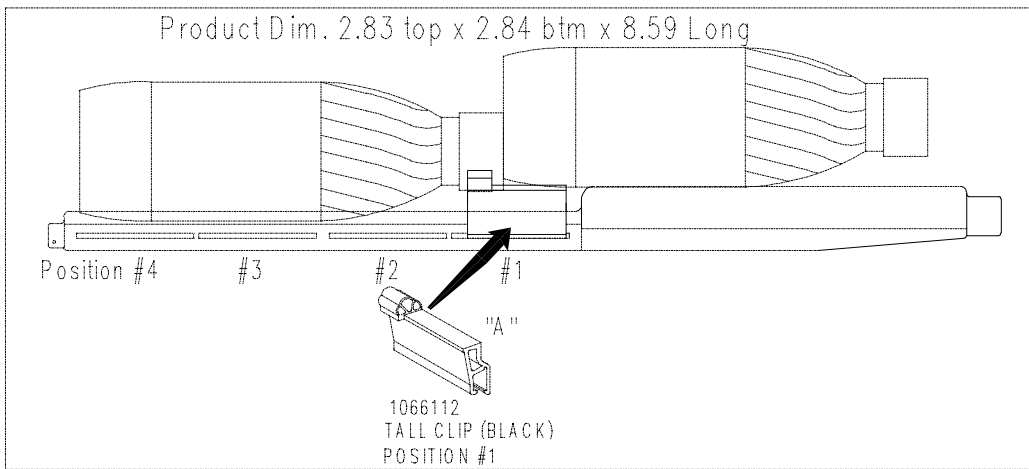

5. SET UP GUIDE.

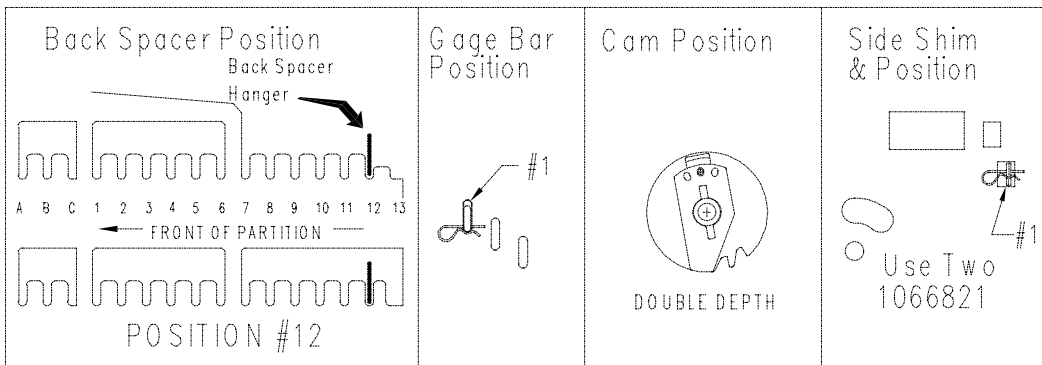

**6. SOLD-OUT LEVER TO BE SHORT STYLE WITH FRONT SPACER.
SPRING TO BE LOCATED ON THE RIGHT SIDE (LOW PRESSURE SETTING).**

**7. FOR OTHER PRODUCT SET UP GUIDES CONTACT THE VENDO COMPANY.
TEL: (209) 439-1770 FAX: (209) 439-2083.**

Vendo[®] Engineering *Uni-2 Set Up Guide*

Size: 20oz

Rev. A Date 2/18/03

Pkg. Description/Type: Gatorade

Franchise: Pepsi Cola

Column Setup

Cam Setting	Back Spacer	Neck Guide Locations	Gage Bar Clip Location	Gage Bar Location	Side Spacer	Sold Out Flap	Sold Out Spacer
2	9	N/A	C/#1	#2	N/A	Short* 1083449	1077457

Note: To properly vend product, the Uni-2 must have the columns set up as illustrated. *Spring Loc. Rt (Low Tension) side.

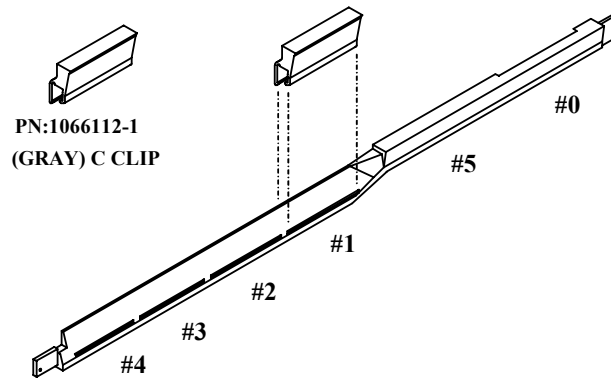

Gage Bar Clip Location

Set Up Guide

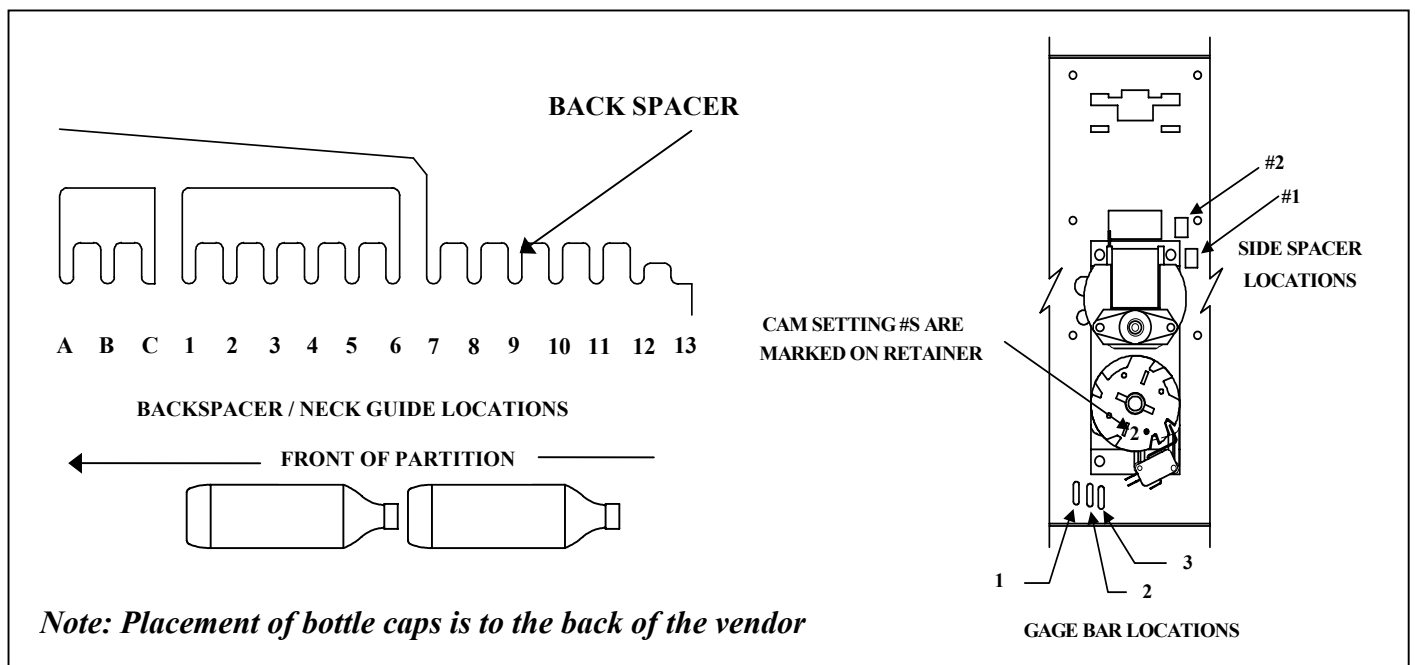

FOR OTHER PRODUCT SET-UP GUIDES, CONTACT THE VENDO COMPANY
 TEL: (559) 439-1770 FAX: (559) 650-3455

1. PRODUCT

20 OZ. PEPSI LIPTON BRISK ICE TEA PET SWIRL TOP - 2.86 Top x 2.90 Btm x 8.71 Long

2. PRODUCT CAPACITY

28 PER COLUMN - 72", 34 PER COLUMN - 79"

3. SET UP GUIDE UNIVENDOR-2

Product	CAM POSITION	BACK SPACER	GAGE BAR	Sold out Lever	SIDE SHIM	GAGE BAR CLIP	
						Part No.	Position
20 oz PEPSI	2	13	1	389242 SHORT	TWO 1066821	1066112	1

Note: To properly vend 20 oz. Lipton. The Univendor-2 must have the columns setup correctly.

4. GAGE BAR CLIP SET UP.

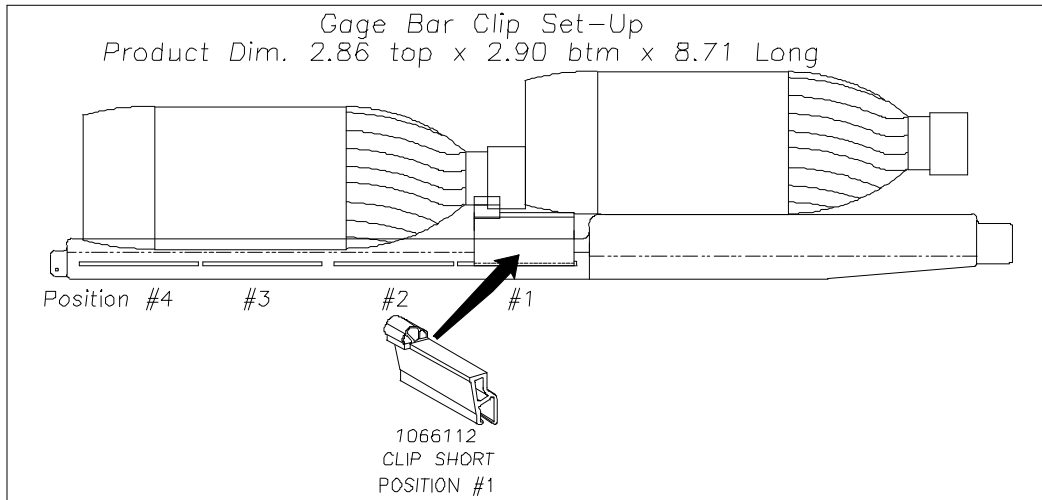

5. SET UP GUIDE.

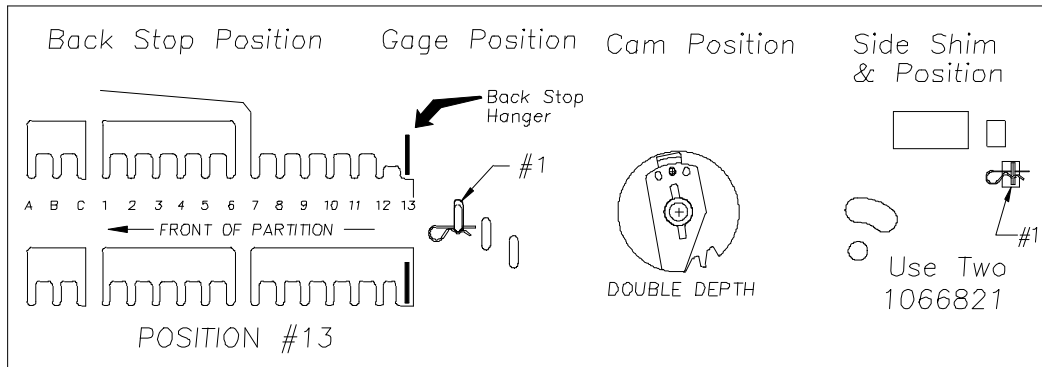

6. SOLD-OUT LEVER TO BE SHORT STYLE WITH FRONT SPACER. SPRING TO BE LOCATED ON THE RIGHT SIDE (LOW PRESSURE SETTING).

1. PRODUCT

20 OZ. PEPSI PET SWIRL TOP - 2.86 Top x 2.90 Btm x 8.71 Long

2. PRODUCT CAPACITY

28 PER COLUMN - 72", 34 PER COLUMN - 79"

3. SET UP GUIDE UNIVENDOR-2

Product	CAM POSITION	BACK SPACER	GAGE BAR	Sold out Lever	SIDE SHIM	GAGE BAR CLIP	
						Part No.	Position
20 oz PEPSI	2	13	1	389242 SHORT	TWO 1066821	1066112	1

Note: To properly vend 20 oz. Pepsi. The Univendor-2 must have the columns setup correctly.

4. GAGE BAR CLIP SET UP.

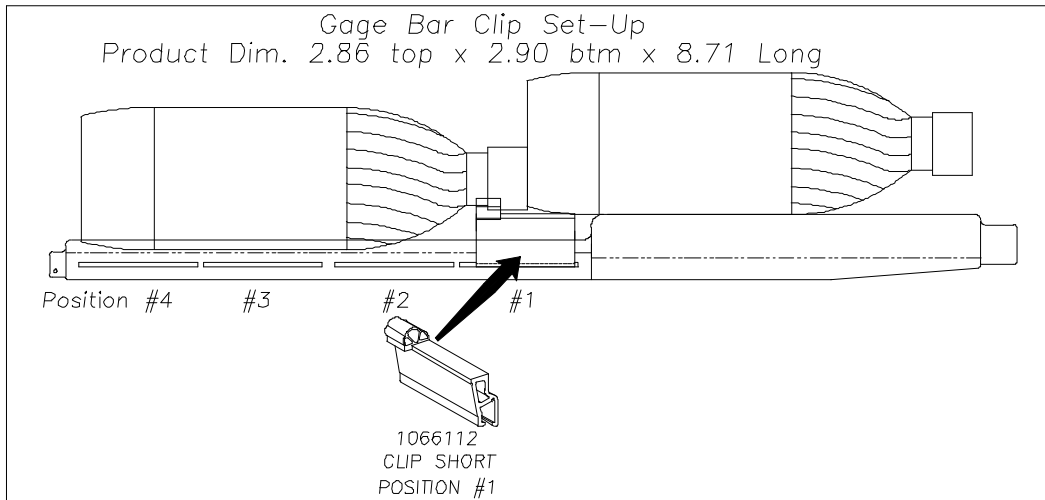

5. SET UP GUIDE.

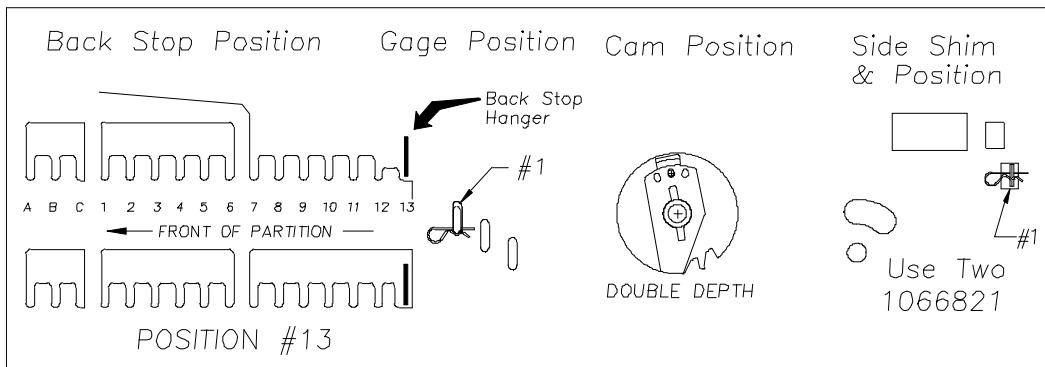

6. SOLD-OUT LEVER TO BE SHORT STYLE WITH FRONT SPACER. SPRING TO BE LOCATED ON THE RIGHT SIDE (LOW PRESSURE SETTING).

Vendo[®] Engineering Uni-2 Set Up Guide

Size: 20oz / 591ml

Rev. A Date 9/9/01

Pkg. Description/Type: TROPICANA TWISTER PET

Franchise: PEPSI

KIT#

Column Setup

Cam Setting	Back Spacer	Neck Guide Locations	Gage Bar Clip Location	Gage Bar Location	Side Spacer	Sold Out Flap	Sold Out Spacer
2	11	N/A	C/#1	#1	N/A	Short* 1083449	1077457

Note: To properly vend product the Uni-2 must have the columns set up as illustrated. *Spring Loc. Rt (Low Tension) side.

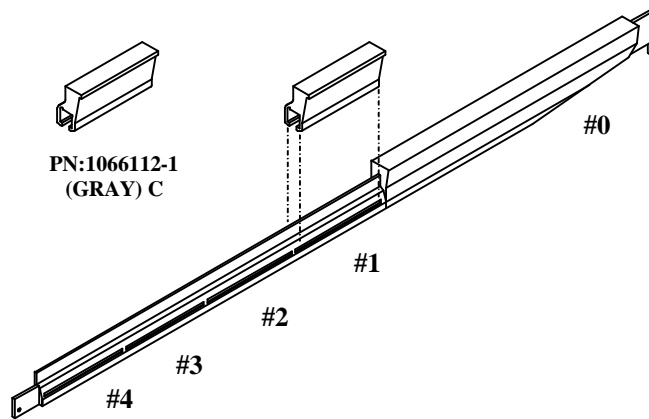

Gage Bar Clip Location

Set Up Guide

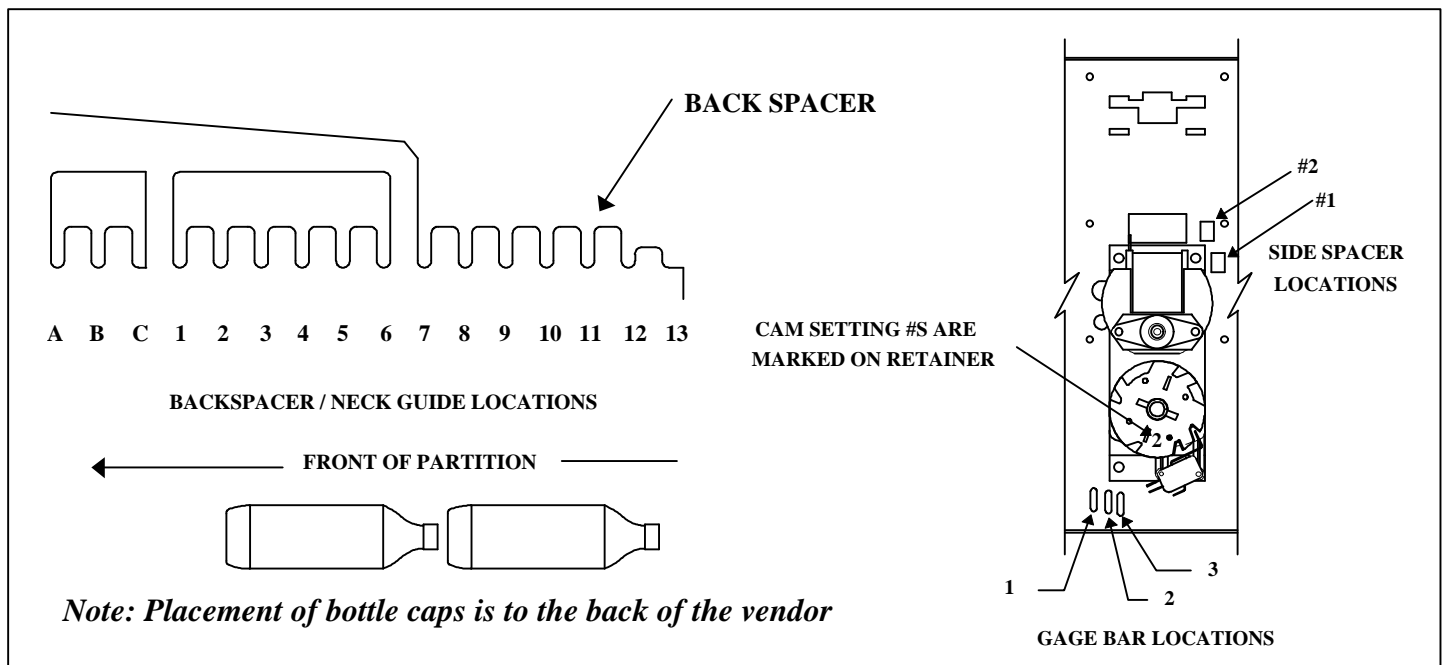

FOR OTHER PRODUCT SET-UP GUIDES, CONTACT THE VENDO COMPANY
 TEL: (559) 439-1770 FAX: (559) 650-3455.

Installation Instruction #

Vendo[®] Engineering Uni-2 Set Up Guide

Size: 500ml

Rev. A Date

02/28/01

Pkg. Description/Type: CLEAR CHOICE WATER - PET

Franchise: PEPSI COLA - MEXICO

KIT#

Column Setup

Cam Setting	Back Spacer	Neck Guide Locations	Gage Bar Clip Location	Gage Bar Location	Side Spacer	Sold Out Flap	Sold Out Spacer
2	11	N/A	C/#1	#2	1060686 Loc. #2	Short* 1083449	1077457

Note: To properly vend product the Uni-2 must have the columns set up as illustrated. *Spring Loc. Rt (Low Tension) side.

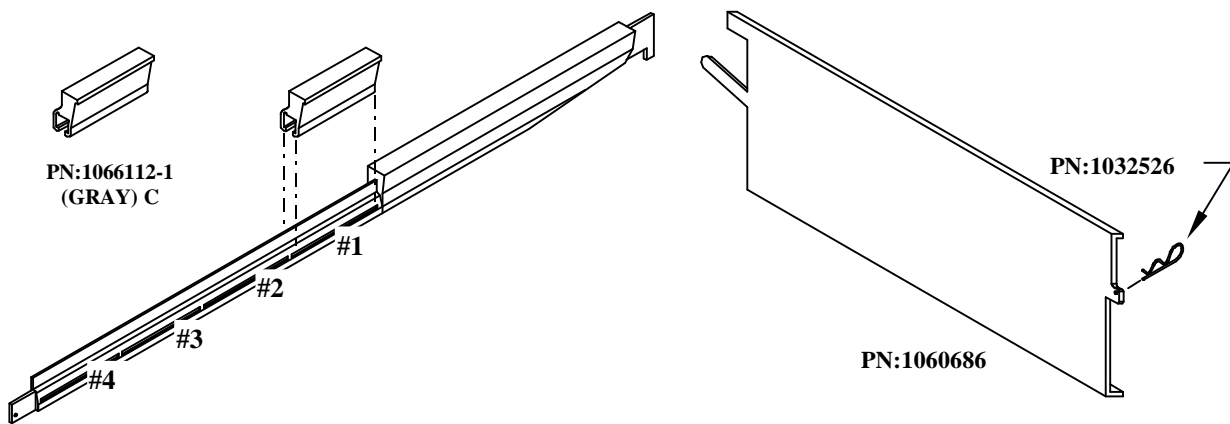

Gage Bar Clip Location

Shim/Spacer

Set Up Guide

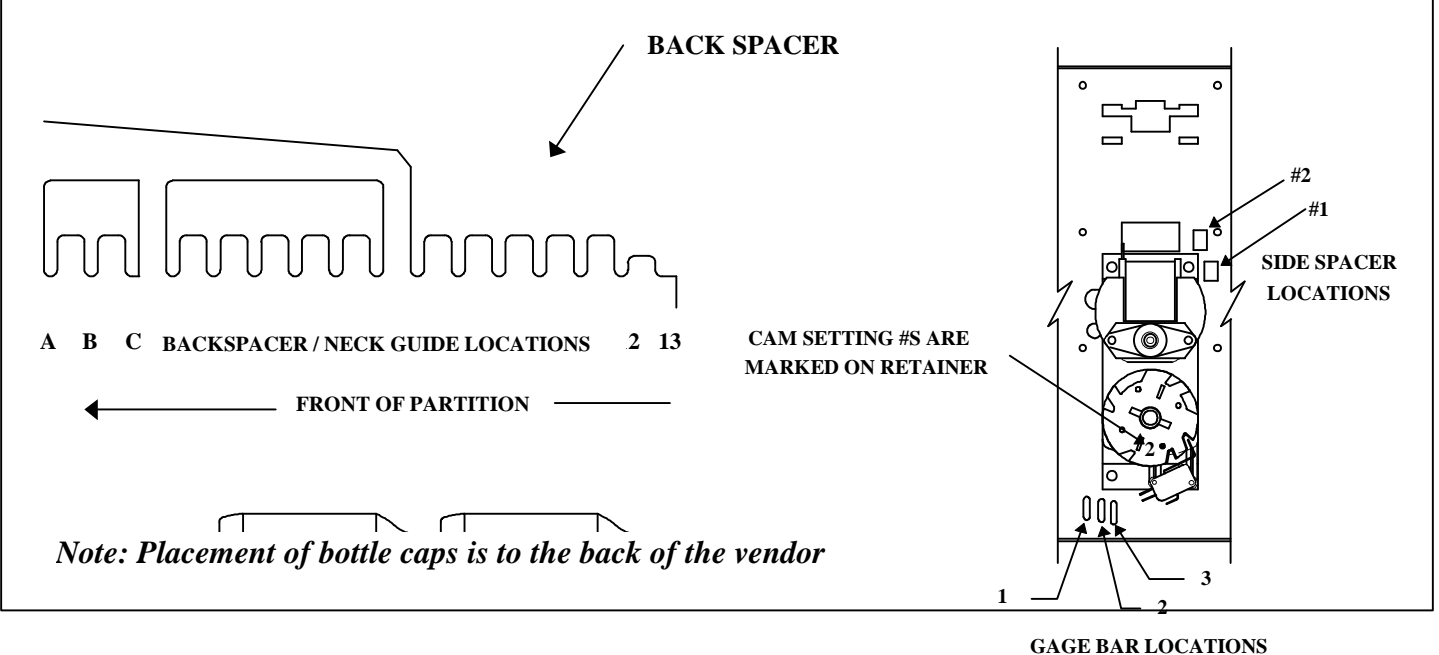

**FOR OTHER PRODUCT SET-UP GUIDES, CONTACT THE VENDO COMPANY
TEL: (559) 439-1770 FAX: (559) 650-3455.**

1. PRODUCT

600ML AQUAFINA PET 12 SWIRL TOP - 2.85 Top x 2.87 Btm x 8.63 Long

2. PRODUCT CAPACITY

28 PER COLUMN - 72", 34 PER COLUMN - 79"

3. SET UP GUIDE UNIVENDOR-2

Product	CAM	BACK	GAGE	Sold out	SIDE	GAGE BAR CLIP		BOTTLE
	POSITION	SPACER	BAR		SHIM	Part No.	Position	
600ml Aquafina	2	12	1	389242 SHORT	1074465 TWO	1066112	1	1120694

Note: To properly vend Aquafina. The Univendor-2 must have the columns setup correctly.

4. GAGE BAR CLIP SET UP.

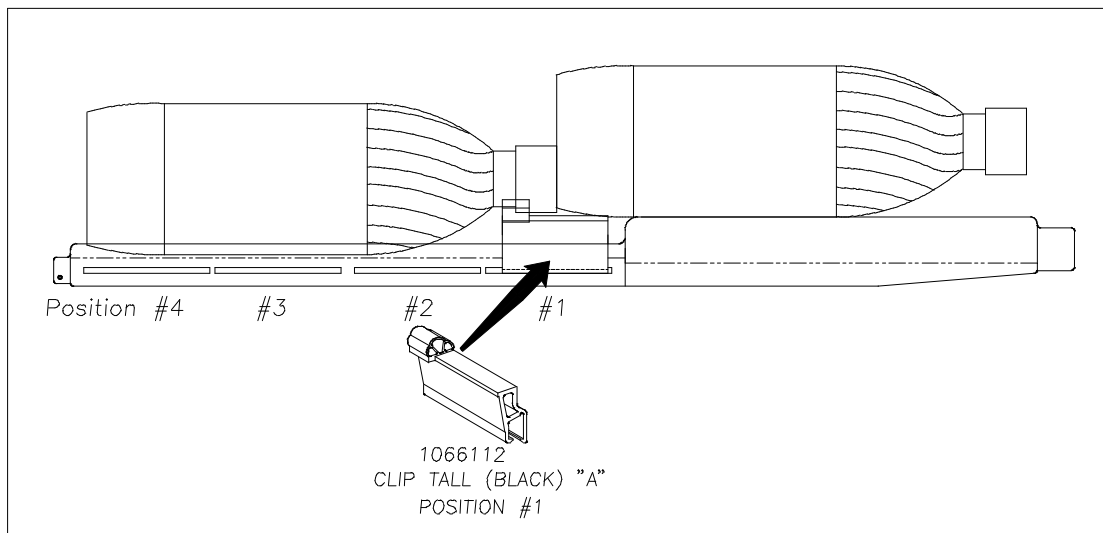

5. SET UP GUIDE.

Back Spacer Position	Gage Bar Position	Cam Position	Side Shim & Position

6. Bottle Guide Position Set-Up: (requires kit #1120694)

Right Hand Partition set wire guide in C position, Left Hand Partition set wire guide in B position.

7. SOLD-OUT LEVER TO BE SHORT STYLE WITH NEW FRONT SPACER #1077457: Spring to be located on the right side (low pressure setting).

8. FOR OTHER PRODUCT SET UP GUIDES CONTACT VENDO COMPANY.

TEL: (559) 439-1770 FAX: (559) 439-2083.

1. PRODUCT

600ML PEPSI LIPTON BRISK ICE TEA PET 12 SWIRL TOP - 2.85 Top x 2.87 Btm x 8.67 Long

2. PRODUCT CAPACITY

28 PER COLUMN - 72", 34 PER COLUMN - 79"

3. SET UP GUIDE UNIVENDOR-2

Product	CAM	BACK	GAGE	Sold out	SIDE	GAGE BAR CLIP		BOTTLE
	POSITION	SPACER	BAR		SHIM	Part No.	Position	
600ml Lipton	2	12	1	389242 SHORT	1074465 TWO	1066112	1	1088236

Note: To properly vend 600ml Lipton. The Univendor-2 must have the columns setup correctly.

4. GAGE BAR CLIP SET UP.

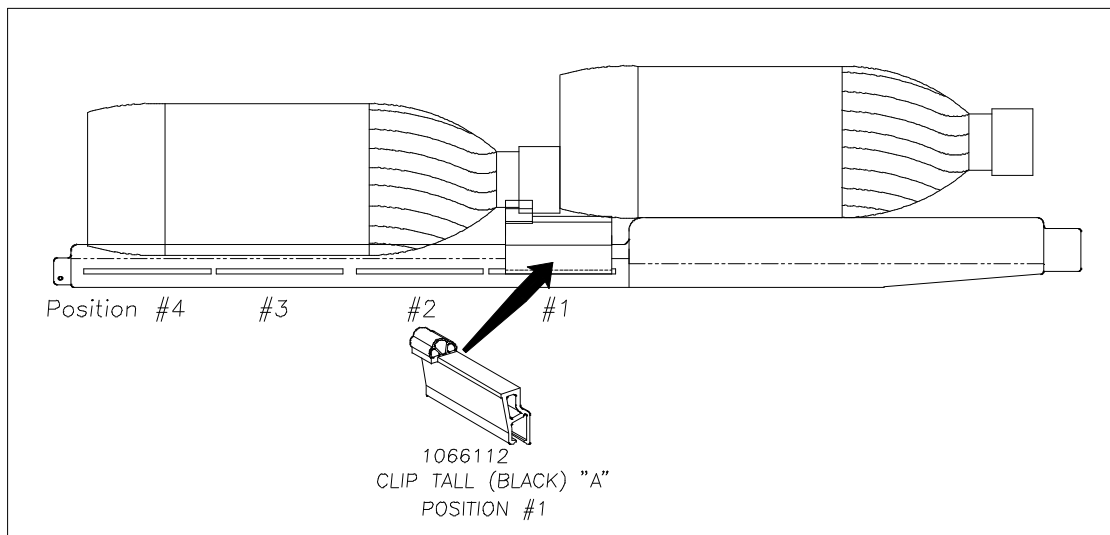

5. SET UP GUIDE.

Back Spacer Position	Gage Bar Position	Cam Position	Side Shim & Position

6. Bottle Guide Position Set-Up: (requires kit #1088236) Right Hand Partition set in C position, Left Hand Partition set in B position.

7. SOLD-OUT LEVER TO BE SHORT STYLE WITH NEW FRONT SPACER #1077457: Spring to be located on the right side (low pressure setting).

**8. FOR OTHER PRODUCT SET UP GUIDES CONTACT VENDU COMPANY.
TEL: (209) 439-1770 FAX: (209) 439-2083.**

1. PRODUCT

281 ML, 9.5 OZ. STARBUCK COFFEE CAN - 2.37 x 4.86 Long

2. PRODUCT CAPACITY

51 PER COLUMN - 72", 60 PER COLUMN - 79"

3. SET UP GUIDE UNIVENDOR-2

Product	CAM POSITION	BACK SPACER	GAGE BAR	Sold out Lever	SIDE SPACER	GAGE BAR CLIP	
						Part No.	Position
281 ML Starbucks	3	8	2 Front	389242 SHORT	1069791	TWO	1
			3 Rear			1066104	2

Note: To properly vend 281 ML Starbucks. The Univendor-2 must have the columns setup correctly.

4. GAGE BAR CLIP SET UP.

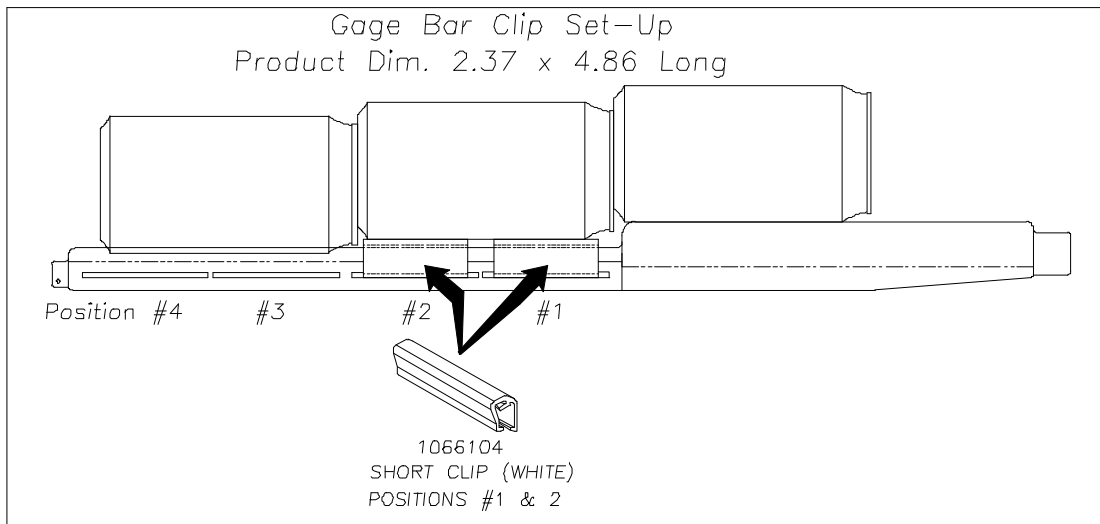

5. SET UP GUIDE.

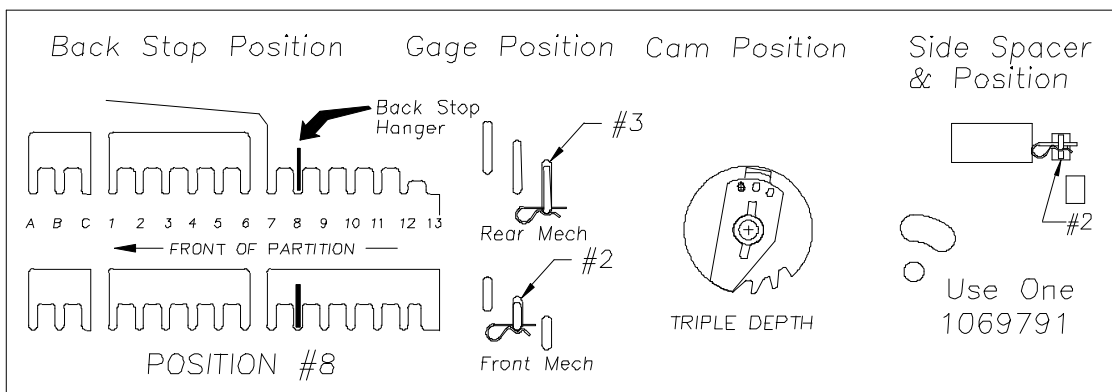

6. SOLD-OUT LEVER TO BE SHORT STYLE WITH FRONT SPACER. SPRING TO BE LOCATED ON THE RIGHT SIDE (LOW PRESSURE SETTING).

1. PRODUCT

281 ML, 9.5 FL. OZ. GLASS STARBUCK COFFEE - 2.44 SQUARE x 6.09 Long

2. PRODUCT CAPACITY

30 PER COLUMN - 72", 36 PER COLUMN - 79"

3. SET UP GUIDE UNIVENDOR-2

Product	CAM POSITION	BACK SPACER	GAGE BAR	Sold out Lever	Side Spacer	Alignment Spacer	GAGE BAR CLIP	
							Part No.	Position
281 ML Starbucks	2	4	2	389242 SHORT	1060686	1080317	1066112	1
							1066112-1	2

Note: To properly vend 281ML Starbucks. The Uni-2 must have the columns setup correctly.

4. GAGE BAR CLIP SET UP.

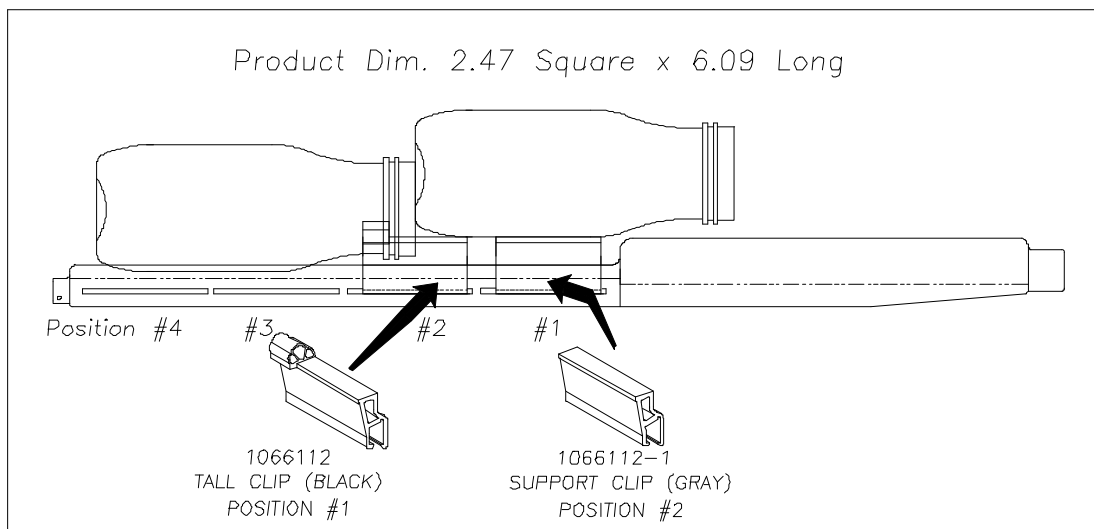

5. SET UP GUIDE.

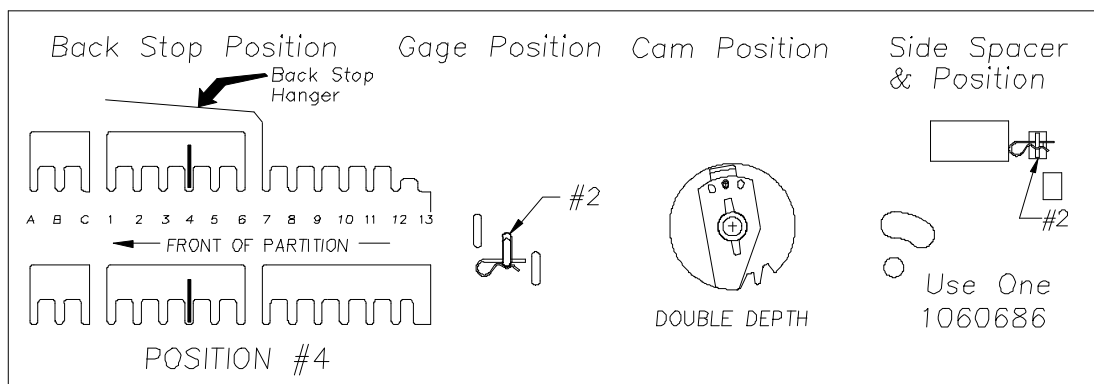

6. SOLD-OUT LEVER TO BE SHORT STYLE NEW FRONT SPACER #1077457. SPRING TO BE LOCATED ON THE RIGHT SIDE (LOW PRESSURE SETTING).